

Structure Selection Report

Interstate 25/Crossroads Boulevard Structure No. C-17-GL (NB) Structure No. C-17-GM (SB)

Prepared for:



Colorado Department of Transportation, Region 4

2207 E. Highway 402

Loveland, CO 80537

Prepared by:

Felsburg Holt & Ullevig

6300 South Syracuse Way, Suite 600

Centennial, CO 80111

303.721.1440

In association with:

AECOM

CDOT Project No./Code IM 0253-242 (20575)

FHU Reference No. 112348-04

June 2015

TABLE OF CONTENTS

	<u>Page</u>
Section 1: Introduction	1
1.1 Project Description	1
1.2 Site Location.....	2
1.3 Existing Structures	2
Section 2: Project Criteria	3
2.1 Structural Design and Geometric Layout.....	3
2.2 Interim Roadway Cross-section	4
2.3 Ultimate Roadway Cross-section	5
2.4 Geotechnical Information	5
Section 3: Preliminary Design Basis, Recommended Superstructure, and Constructability Considerations	6
3.1 Design Constraints	6
3.2 Recommended Superstructure Type.....	6
3.3 Constructability Considerations.....	7

APPENDICES

Appendix A	General Layout and Structure Inspection Report for Existing Bridges
Appendix B	Draft I-25 Corridor Common Structural Elements and Design Criteria for the Preparation of Site-Specific Structure Selection Reports, May 2013
Appendix C	General Layout, Typical Section, and Phasing for Proposed Bridges

LIST OF FIGURES

	<u>Page</u>
Figure 1. I-25/Crossroads Boulevard Standard Diamond Interchange – North I-25 EIS Preferred Alternative	1
Figure 2. Crossroads Boulevard Cross-section (Interim) at Bridge	4
Figure 3. I-25 Cross-section (Interim) at Bridge	4
Figure 4. Crossroads Boulevard Cross-section (Ultimate) at Bridge	5
Figure 5. I-25 Cross-section (Ultimate) at Bridge.....	5

Section 1: Introduction

1.1 Project Description

The North I-25 Environmental Impact Statement (EIS), published in August 2011, identified and evaluated multimodal transportation improvements along approximately 61 miles of the Interstate 25 (I-25) corridor from the Fort Collins-Wellington area to Denver. A reconstructed standard diamond interchange configuration with signalized ramp terminals was identified for the I-25/Crossroads Boulevard Interchange as part of the EIS and again recommended in the Final Interchange Type Selection Report dated November 2014. The functionality of this interchange configuration is achieved in part by carrying I-25 over Crossroads Boulevard on parallel bridge structures.

This report summarizes the preferred structure type within the I-25/Crossroads Interchange (see **Figure 1**). The intent is to replace the bridge structures to meet current American Association of State Highway and Transportation Officials (AASHTO) Load & Resistance Factor Design (LRFD) and Colorado Department of Transportation (CDOT) standards. The replacement bridges will be built in the same location as the existing structures.



Figure 1. I-25/Crossroads Boulevard Standard Diamond Interchange – North I-25 EIS Preferred Alternative

During the course of the conceptual design development, CDOT secured Responsible Acceleration of Maintenance and Partnerships (RAMP) funding for an interim improvement project at the I-25/Crossroads Boulevard interchange. Funding requirements necessitate that the interim improvements be constructed by 2017. The goal of these improvements include replacing the I-25 bridges, retaining the roundabouts at the ramp terminals, and advancing the associated I-25 mainline to an interim stage, preparing the area for the future express lanes build-out.

1.2 *Site Location*

The I-25/Crossroads Boulevard interchange is located in unincorporated Larimer County, approximately 2 miles north of the I-25/US Highway 34 (US 34) interchange at Mile Post 259.3. The municipal boundary of Loveland is to the west and the municipal boundary of Windsor is located to the east of the interchange. Crossroads Boulevard is a paved east-west county road that extends from Rocky Mountain Avenue to State Highway (SH) 257. Crossroads Boulevard is a four-lane roadway from Rocky Mountain Avenue to about one mile east of I-25 where it becomes a two-lane roadway. The existing I-25/Crossroads Boulevard interchange is a standard diamond interchange with roundabouts, providing for a two-lane section of Crossroads Boulevard under the I-25 bridges.

1.3 *Existing Structures*

The existing I-25 bridges were built in 1965 with deck and bridge rail rehabilitation in the mid-1980s. Structure No. C-17-ES is a 3-span cast-in-place concrete slab and girder bridge (30'-30'-30') carrying northbound traffic. Structure No. C-17-ET is a 3-span bridge of similar type (22'-30'-22') carrying southbound traffic. Each structure currently carries two 12-foot traffic lanes with a 4-foot inside shoulder and a 10-foot outside shoulder. Bridge rails are on a 2-foot wide curb for an out to out width of 42'-0" at each bridge. The bridges are on both a vertical and horizontal tangent with a 90 degree skew between I-25 and the centerline of Crossroads Boulevard. Both bridges have sufficiency ratings above 80 according to the latest CDOT Structure Inspection Reports, but are identified as functionally obsolete. Existing bridge plans and the latest available structure selection report can be found in **Appendix A**.

Section 2: Project Criteria

2.1 Structural Design and Geometric Layout

Structural design guidelines for the North I-25 corridor within CDOT Region 4 are in the process of being developed and are documented in the *Draft I-25 Corridor Common Structural Elements and Design Criteria for the Preparation of Site-Specific Structure Selection Reports, May 2013* (see **Appendix B**); hereby referred to as the *Base SSR*. The purpose of this common report is, among many things, intended to establish the design criteria for all new structures along the corridor and to document base aesthetic criteria for these structures. Sections 5 and 6 of the *Base SSR* will apply to the I-25 bridges over Crossroads Boulevard. Section 3.4 of the *Base SSR* will apply to retaining walls.

The geometric recommendations in Sections 2.2 and 3.2 of the *Base SSR* for I-25 over state highways and county roads were modified to fit the mutually agreed upon needs of CDOT and the City of Loveland at this intersection. Discussion points such as safety, graffiti concerns, matching aesthetics in the area, and the desire to keep the roundabouts, all contributed to the decision to provide single span structures over Crossroads Boulevard. The requirements include:

- Maintain a clear span and open feeling beneath the bridges (i.e., no pier column in the median of Crossroads Boulevard). This will also allow the City the most flexibility with future traffic configurations and will avoid any utility conflicts during construction.
- Shorten the overall span length as much as possible.
- Provide a wall configuration beneath the bridges to support the first two bullets above. Wall height should be set such that the walls are not easily climbable.

2.2 Interim Roadway Cross-section

The objective of the interim improvement project is to utilize as much of the existing Crossroads Boulevard as possible, leaving the roundabouts in place, tying the new ramps into the existing, and minimizing right-of-way impacts. Crossroads Boulevard between the roundabouts will be widened to four 12-foot lanes with 5-foot bike lanes in each direction, a 6-foot median, and a 6-foot sidewalk in each direction located in the ultimate location (see **Figure 2**). Retaining walls set 2-feet off the sidewalk and directly in front of the abutments will reduce overall bridge length and allow for a more stubby abutment configuration.

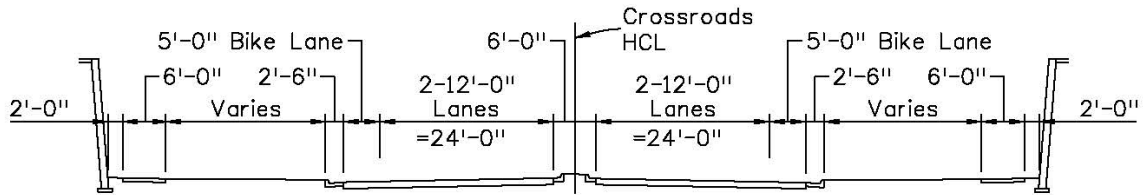

Figure 2. Crossroads Boulevard Cross-section (Interim) at Bridge

The improved I-25 cross-section at the bridges (64-feet clear; 67-feet out to out) will include a 12-foot outside shoulder and two 12-foot general purpose lanes. The northbound bridge will be built and striped for a 28-foot inside shoulder to accommodate phasing needs and the future 12-foot express lane and 4-foot buffer (see **Figure 3**). The southbound bridge will also be built to accommodate the future express lane, but will be striped with a 16-ft shoulder in the interim.

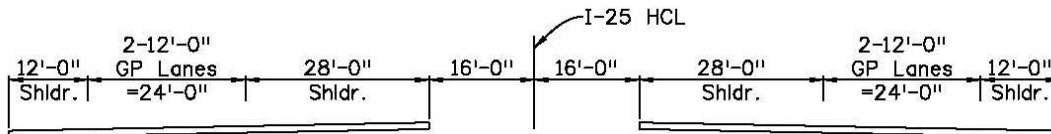

Figure 3. I-25 Cross-section (Interim) at Bridge

2.3 Ultimate Roadway Cross-section

A standard diamond interchange with signalized ramp terminals is recommended for the ultimate configuration. The Crossroads Boulevard roadway cross-section between the signals will provide two 12-foot through lanes and a 12-foot turn lane in each direction with a back-to-back median separated shared turn lane in the middle (see **Figure 4**). Bicyclists and pedestrians will continue to be accommodated.

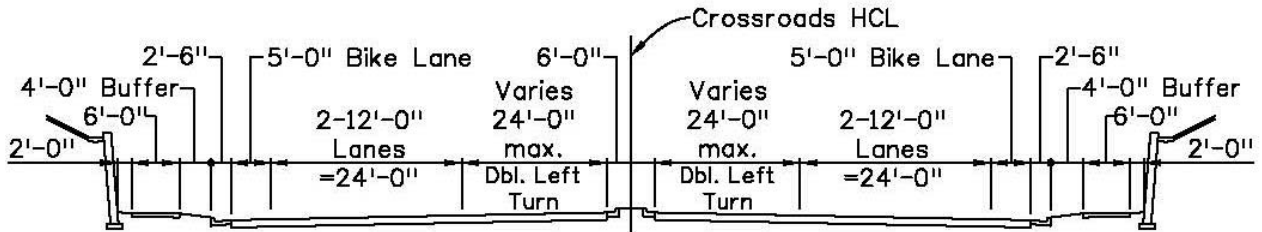

Figure 4. Crossroads Boulevard Cross-section (Ultimate) at Bridge

The I-25 cross-section at the bridge will be 76-feet clear (79-feet out to out) and will include a 12-foot outside shoulder, three 12-foot general purpose lanes, a 12-foot express lane with 4-foot buffer, and a 12-foot inside shoulder (see **Figure 5**). This configuration will require a 12-foot future widening of each bridge.

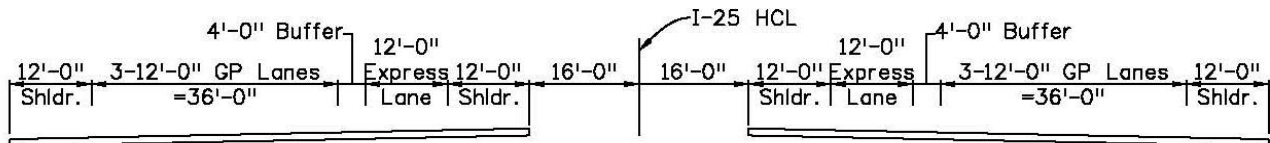

Figure 5. I-25 Cross-section (Ultimate) at Bridge

2.4 Geotechnical Information

The geotechnical investigation for the structures at this interchange is currently being conducted. Review of the as-constructed bridge plans and preliminary discussion with the geotechnical engineer indicated that bedrock is shallow at the bridge sites. Shallow bedrock indicates that abutments founded on drilled caissons may be the more feasible substructure recommendation over abutments founded on H-piling.

Section 3: Preliminary Design Basis, Recommended Superstructure, and Constructability Considerations

3.1 Design Constraints

The proposed northbound (C-17-GL) and southbound (C-17-GM) I-25 bridges over Crossroads Boulevard will replace the existing three span concrete T-beam twin bridge structures built in 1963. Design constraints are as follows:

1. A 69-foot interim roadway cross-section and 129-foot ultimate roadway cross-section for Crossroads Boulevard beneath both northbound and southbound I-25 structures require longer spans for the new bridges.
2. A vertical clearance of 16'-6" is required as I-25 passes over Crossroads Boulevard. Because the roadway profiles for both northbound and southbound I-25 are being re-graded, structure depth was not deemed critical. Vertical clearance is set for the ultimate bridge configuration.
3. Eliminating pier columns in the median of Crossroads Boulevard is preferred to maintain a clear sight zone beneath the structures and to avoid current and future utility conflicts.
4. The northbound and southbound structures both have a width of 67-feet with a single 12-foot future widening. Both interim structures will be constructed in a single phase.
5. A single span structure approximately 140-feet long is within the fabrication capacity of standard bulbed-T girders.
6. The twin bridges are placed at a 90 degree angle to the centerline of I-25 for simplicity and ease of construction and future maintenance.

3.2 Recommended Superstructure Type

The preferred structure type is a precast prestressed BT84 girder superstructure with an 8-inch deck on integral, caisson supported abutments placed behind retaining walls. Retaining walls are anticipated to be soil nail walls directly under the bridge, and transition to MSE walls in fill conditions. Given the proposed Crossroads Boulevard cross-section, the BT84 girders are more economical than multi-span configurations due to reduced structure length and elimination of piers.

The resulting twin structure is a single span (140'-0") precast prestressed BT84 girder bridge. The interim width of each bridge will be 67-feet from edge of deck to edge of deck to accommodate two 12-foot lanes, a 12-foot shoulder, a 28-foot shoulder, and Type 10 bridge rails. The 28-foot shoulder width will accommodate a 12-foot future managed lane and 4-foot buffer zone along with a 12-foot shoulder. This width is also necessary on the northbound structure in order to accommodate a temporary phase of construction during which both northbound and southbound traffic will be carried. The ultimate width of both structures will be approximately 79-feet from edge of deck to edge of deck to accommodate three 12-foot general purpose lanes, two 12-foot shoulders, a 4-foot buffer with 12-foot express lane, and Type 10 bridge rails. Refer to **Appendix C** for General Layout and Typical Section.

3.3 *Constructability Considerations*

The interim structures for both northbound and southbound I-25 will be constructed without phasing by utilizing a traffic shift during construction. To accommodate this, the existing southbound structure must be temporarily widened to the west to handle both directions of I-25 traffic while the northbound bridge is reconstructed. The planned 67-ft out to out width of the northbound structure will accommodate both directions of I-25 traffic while the southbound bridge is reconstructed.

Appendix A

*General Layout and Structure Inspection Report
for Existing Bridges*

REVISIONS

Revised: Changed Span No 2 C-17-ET from 22'-0" to 30'-0"; Plan, Profile & Quantities -- 3-19-64 RRA.

FED. ROAD DIST. NO.	DIVISION	PROJECT NO.	SHEET NO.	TOTAL SHEETS
9	COLO.	125-3(35)258	53	

SUMMARY OF QUANTITIES

ITEM	DESCRIPTION	UNIT	SUPERSTRUCTURE		ABUT. No. 1		PIER No. 2		PIER No. 3		ABUT. No. 4		TOTALS	
			C-17-ES	C-17-ET	C-17-ES	C-17-ET	C-17-ES	C-17-ET	C-17-ES	C-17-ET	C-17-ES	C-17-ET	C-17-ES	C-17-ET
14	UNCLASSIFIED STRUCTURAL EXCAVATION (BRIDGE)	Cu.Yd.			110	68	60	49	60	50	110	68	340	235
16	STRUCTURE BACKFILL (CLASS X)	Cu.Yd.			105	39	50	41	50	41	105	39	310	160
46	CLASS "A" CONCRETE	Cu.Yd.	1472	112.8	250	197	209	20.4	20.9	20.4	250	19.7	239	193
47	REINFORCING STEEL (INCLUDES 12" FOR OVERRUN)	Lbs.	45,070	36,575	2965	1,890	3,645	2,755	3,645	2,755	2,965	1,890	58,240	45,865
48	STRUCTURAL STEEL (GALVANIZED)	Lbs.	6,365	5,390									6,365	5,390
65	CONCRETE SLOPE AND DITCH PAVING (w/ WIDE AREA)	Cu.Yd.			45	30					45	30	90	60

① DO NOT INCLUDE GALVANIZING. NO PERCENTAGE SHALL BE ADDED TO WEIGHT OF BARE METAL FOR SPALLER COATING.

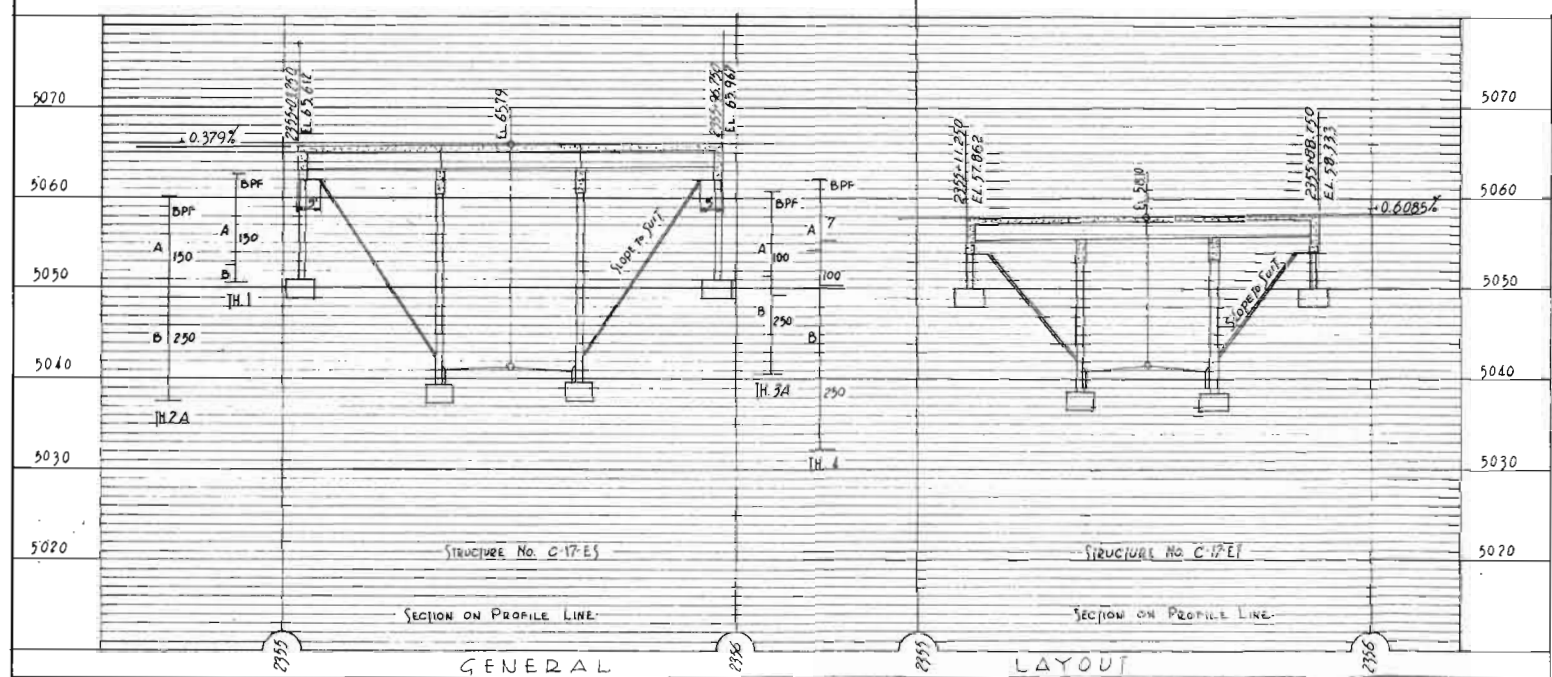
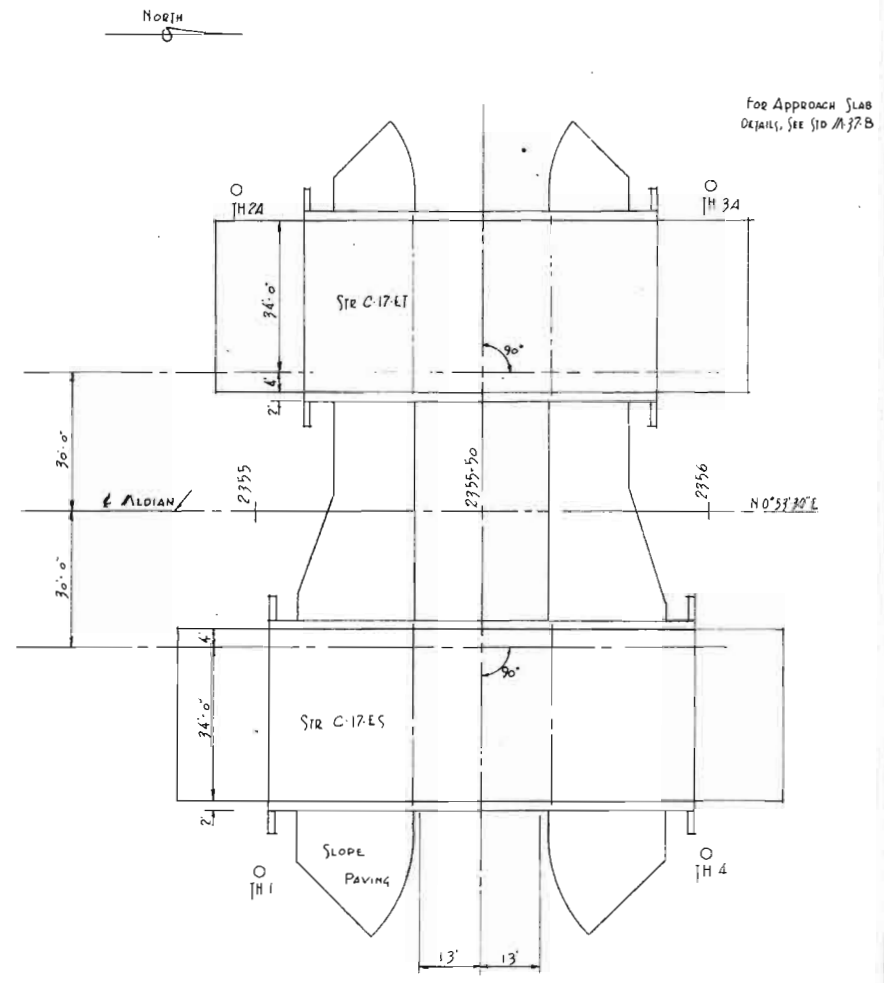

GENERAL NOTES

ALL WORK SHALL BE DONE ACCORDING TO THE STANDARD SPECIFICATIONS OF THE COLORADO DEPARTMENT OF HIGHWAYS APPLICABLE TO THE PROJECT.
 ALL CONCRETE SHALL BE CLASS "A".
 ALL REINFORCING STEEL SHALL BE INTERMEDIATE GRADE STEEL OF A DEFORMED TYPE. EACH BAR SHALL BE TAGGED WITH THE BAR DESIGNATION AND STATION NUMBER OF THE PROJECT.
 IF BY PERMISSION OF THE ENGINEER PRIMARY BARS ARE SPICED, THEY SHALL LAP A MINIMUM OF 28 DIAMETERS FOR BARS NEAR TOPS OF BEAMS HAVING MORE THAN 12 INCHES OF CONCRETE UNDER THE BARS, AND 17 DIAMETERS FOR BARS NEAR BOTTOM OF MEMBERS. SECONDARY BARS WHEN SPICED SHALL LAP 17 DIAMETERS OF THE BAR.
 DIMENSIONS FOR REINFORCING STEEL NOT SHOWN AS CLEAR SHALL BE TO THE CENTERLINE OF THE BAR.
 SOUNDINGS AND DEPTH OF FOOTINGS ARE IN ACCORDANCE WITH THE BEST AVAILABLE DATA, AND WHEN DIFFERENT CONDITIONS ARE ENCOUNTERED THE BRIDGE ENGINEER WILL INSPECT AND DETERMINE IF REDSIGN IS NECESSARY.
 FOOTINGS IN ROCK SHALL BE POURED OUT TO ROCK AND NOT FORMED.
 WHEN EXCAVATING FOR FOOTINGS THE FINAL ONE FOOT IN DEPTH SHALL BE DONE BY HAND-LABOR METHOD.
 FOR DETAILS OF STRUCTURAL EXCAVATION AND STRUCTURE BACKFILL, SEE STANDARD M-16-A ALL CONCRETE SURFACES MARKED WITH THE SYMBOL 7 AS SHOWN ON SHEET NO. 28, SHALL RECEIVE CLASS "T" SURFACE FINISH.
 ALL STRUCTURAL STEEL SHALL BE PAINTED WITH ONE SHOP COAT OF ZINC CHROMATE AND TWO FIELD COATS OF ALUMINUM PAINT UNLESS OTHERWISE NOTED.
 ALL RIVETS SHALL BE 3/4 INCH DIAMETER UNLESS OTHERWISE NOTED.
 HIGH TENSILE BOLTS MAY BE SUBSTITUTED FOR FIELD RIVETS AT THE CONTRACTORS OPTION. BOLTS SHALL BE FURNISHED IN THE AMOUNT OF FIVE PERCENT IN EXCESS OF THE NOMINAL NUMBER REQUIRED FOR EACH SIZE AND LENGTH.
 WELDING SHALL CONFORM TO THE LATEST EDITION OF THE A.W.S. STANDARD SPECIFICATIONS FOR WELDING HIGHWAY BRIDGES.
 FOR WELDED GIRDERS ALL SHOP BUTT WELDS IN FLANGES AND WEBS SHALL BE MADE BEFORE WELDING INTO GIRDERS.
 WHEN CALLED FOR IN THE SPECIAL PROVISIONS, SHOP WELDS SHALL BE INSPECTED RADIOGRAPHICALLY AND BY THE PENETRANT DYE METHOD.
 WHEN TREATED TAPER FILING IS SHOWN ON THE PLANS, THE PRESERVATIVE FOR TREATMENT SHALL BE CRESOTE OIL.
 ALL STRUCT. STEEL (NOT OTHERWISE NOTED) SHALL BE ASTM A36-62T.

LOADING DATA, INTERSTATE ALTERNATE
 LIVE LOAD - A, A. S. M. O. H20-S16-44
 DEAD LOAD - ASSUMES 15 LBS. PER SQ. FT. ADDITIONAL WEARING SURFACE WHICH INCLUDES THE 1/4 INCH CONCRETE MONOLITHIC WEARING SURFACE SHOWN.

DESIGNING DATA.
 f_c = 1,200 Lbs. per Sq. In.
 f_s = 20,000 Lbs. per Sq. In. (GEN'L STEEL & A76 STRUCT. STEEL)
 n = 10
 f_t = 48,000 Psi (A7 STRUCT. STEEL)

COLORADO
 DEPARTMENT OF HIGHWAYS
 3 SPANS @ 28'-0" B.W.D., 3 SPANS @ 30' No. B.W.D.
 CONCRETE SLAB & GIRDERS, 38 Rows. 2 Cures
 GENERAL LAYOUT, SUMMARY of QUANTITIES and GENERAL NOTES
 Across County Road
 Sta. 2755+00
 Near KELVIN Sec. 34 T. 6N R. 88W
 Designed by [Signature]
 Made by [Signature]
 Checked by [Signature]
 Approved by [Signature] Bridge Engineer
 Date: Sept. 16, 1963

SOUNDINGS
 A = SILTY CLAY
 B = SILTY SANDSTONE

• Sta. 2755+02.250 to 2755+96.750 No. BOUND
 • Sta. 2755+11.250 to 2755+88.750 So. BOUND

C-17-ES No. BOUND
 STRUCTURE NO. C-17-ET So. BOUND

Colorado Department of Transportation
Structure Inspection and Inventory Report (English Units)

Highway Number (ON) 5D: 025A
 Mile Post (ON)11: 259.254 mi

Bridge Name: C-17-ES Inspection Date: 5/13/2013 Sufficiency Rating: 93.1 FO

NBI Reporting ID:	C-17-ES
Rgn/Sectn 2E/2M:	41
Trans Region 2T	03
County Code 3:	069
LARIMER	
Place Code 4:	46465
LOVELAND	
Rte.(On/Under)5A:	1
Signing Prefix 5B:	1
Level of Service 5C:	1
Directional Suffix 5E:	0
Feature Intersected 6:	
CROSSROADS BLVD.	
Facility Carried 7:	
25 ML NBND	
Alias Str No.8A:	
Pril Str No. 8P	
C-17-ET	
Location 9:	
2 MI NO OF JCT US 34	
Max Clr 10:	328.1 ft
BaseHiway Net12:	1
IrsinvRout 13A	000000025A
IrrsubRout No13B:	00
Latitude 16:	40d 26' 10"
Longitude 17:	104d 59' 32"
Range18A:	68 W
Township18B:	68
Section18C:	34
Detour Length 19:	0.0 mi
Toll Facility 20:	3
Custodian 21:	1
Owner 22:	1
Functional Class 26:	11
Year Built 27:	1965
Lanes on 28A:	2
Lanes Under 28B:	2
ADT 29:	35,600
Year of ADT 30:	2007
Design Load 31:	5
Apr Rdwy Width 32:	38.0 ft
Median 33:	1
Skew 34:	0.00 °
Structure Flared 35:	0
Sfty Rail 36a/b/c/d:	1 0 1 1
Rail ht36h:	28 "in"

Hist Signif 37:	5
Posting status 41:	A
Service on/un 42A/B:	6 1
Main Mat/Desgn 43A/B:	1 4
Aprr Mat/Desgn 44A/B:	0 0
Main Spans Unit 45:	3
Approach Spans 46:	0
Horiz Clr 47:	38.0 ft
Max Span 48:	30.0 ft
Str Length 49:	93.5 ft
Curb Wdth L/R 50A/B:	0.0 ft 0.0 ft
Width Curb to Curb 51	38.0 ft
Width Out to Out 52:	42.0 ft
Deck Area:	3,950.4 sq. ft
Min Clr Ovr Brgd 53:	99.99
Min Undrclr Ref 54A:	H
Min Undrclr 54B:	21.9 ft
Min Lat Clrnce Ref R 55A:	H
Min Lat Undrclr R 55B:	1.3 ft
Min Lat Undrclr L 56:	0.0 ft
Deck 58:	7
Super 59:	6
Sub 60:	7
Channel/Protection 61:	N
Culvert 62:	N
Optprtng Rtg Method 63:	1 LF Load Factr
Operating Rating 64:	55.8
Inv Rtgng Method 65:	1
Inventory Rating 66:	33.5
Asph/Fill Thick 66T:	000 "in"
Str. Evaluation 67:	6
Deck Geometry 68:	6
Undrclr Vert/Hor 69:	3
Posting 70:	5
Waterway Adequacy 7	N
Approach Alignment 72:	8
Type of Work 75A:	
Work Done By 75B:	
Length of Improvment 76:	0.0 ft
Insp Team Indicator 90B:	RED TEAM
Inspector Name 90C:	JACKSONC
Frequency 91:	24 months
FC Frequency 92A:	
UW Frequency 92B:	
SI Frequency 92C:	
FC Inspection Date 93A:	

UW Inspection Date 93B	
SI Date 93C:	
Bridge Cost 94:	\$ 0
Roadway Cost 95:	\$ 0
Total Cost 96:	\$ 0
Year of Cost Estimate 97:	
Brdr Brgd Code/% 98A/B:	
Border Bridge Number 99:	
Defense Highway 100:	1
Parallel Structure 101:	R
Direction of Traffic 102:	1
Temporary Structure 103	
Highway System 104:	1
Fed Lands Hiway 105:	0
Year Reconstructed 106	0000
Deck Type 107:	1
Wearing Surface 108A	1
Membrane 108B:	0
Deck Protection 108C:	0
Truck ADT 109:	12 %
Trk Net 110:	1
Pier Protection 111:	#
NBIS Length 112:	Y
Scour Critical 113:	N
Scour Watch 113M:	
Future ADT 114:	54,112
Year of Future ADT 115	2027
CDOT Str Type 120A:	CSG
CDOT Constr Type 120B	2.
Inspection Indic 122A:	
Inspection Trip 122AA	
Inspection Schedule ID:	ODD MAY F11
Maintenance Patrol 123:	50
Expansion Dev/Type124	O
Brdg Rail Type/Mod 125A/B	W 0
Posting Trucks 129A/B/C	0 0 0
Str Rating Date 130:	6/27/2006
Special Equip 133:	-1
Vert Clr N/E 134A/B/C:	X 99.99 0
Vert Clr S/W 135A/B/C	X 99.99 0
Vertical Clr Date:	5/5/1905
Weight Limit Color: 139	0
Str Billing Type:	U
Userkey 1 - System:	ONSYS
Userkey 7-Update Indic	

Inspector Name: JACKSONC

Colorado Department of Transportation
Structure Inspection and Inventory Report (English Units)

Highway Number (ON) 5D: 025A

Mile Post (ON)11: 259.254 mi

Element Inspection Report

Elm/En	Description	Units	Total Qty	% in 1	CS 1	% in 2	CS 2	% in 3	CS 3	% in 4	CS 4	% in 5	CS 5
12/1	Bare Concrete Deck	(SF)	3,927	0 %	0	100 %	3,927	0 %	0	0 %	0	0 %	0
110/1	R/Conc Open Girder	(LF)	470	98 %	460	2 %	10	0 %	0	0 %	0	0 %	0
205/1	R/Conc Column	(EA)	6	100 %	6	0 %	0	0 %	0	0 %	0	0 %	0
215/1	R/Conc Abutment	(LF)	84	100 %	84	0 %	0	0 %	0	0 %	0	0 %	0
234/1	R/Conc Cap	(LF)	76	78 %	59	20 %	15	3 %	2	0 %	0	0 %	0
301/1	Pourable Joint Seal	(LF)	84	88 %	74	12 %	10	0 %	0	0 %	0	0 %	0
308/1	Constr Non Exp Jt	(LF)	168	100 %	168	0 %	0	0 %	0	0 %	0	0 %	0
321/1	R/Conc Approach Slab	(EA)	2	100 %	2	0 %	0	0 %	0	0 %	0	0 %	0
325/1	Slope Prot/Berms	(EA)	2	0 %	0	100 %	2	0 %	0	0 %	0	0 %	0
326/1	Bridge Wingwalls	(EA)	4	100 %	4	0 %	0	0 %	0	0 %	0	0 %	0
334/1	Metal Rail Coated	(LF)	188	100 %	188	0 %	0	0 %	0	0 %	0	0 %	0
338/1	Conc Curbs/SW	(LF)	188	100 %	188	0 %	0	0 %	0	0 %	0	0 %	0
340/1	Superstr Cnc Coating	(EA)	1	100 %	1	0 %	0	0 %	0	0 %	0	0 %	0
341/1	Substr Conc Coating	(EA)	1	100 %	1	0 %	0	0 %	0	0 %	0	0 %	0
359/1	Soffit Smart Flag	(EA)	1	100 %	1	0 %	0	0 %	0	0 %	0	0 %	0

Elem/Env	Description	Element Notes
12/1	Bare Concrete Deck	Minor wear in driving lanes. Some spalls/potholes, and asphalt patches, along joint at Pier 3. (See 2011 Photo) Some D-cracking along const. joints at piers. 2013, roadway needs resealed and patched over P3. Short light trans. cracks scattered throughout.
110/1	R/Conc Open Girder	Shear cracks in ends at abutments. Light vert. flexure cracks throughout. Delam. at end of Girder A at Pier 3.
205/1	R/Conc Column	Look good.
215/1	R/Conc Abutment	Some light vert. cracks in both, few with efflorescence. Cracking with efflor. along cold jt. with deck at Abutment 1.
234/1	R/Conc Cap	Minor horiz. delam. cracking at both ends of Pier 2 cap, rust stains also at left. Some light scale with efflor. under Gir. 2E at Pier 2. Horiz. delam. cracking at left and right ends of Pier 3 cap in Span 3. Waterstained.
301/1	Pourable Joint Seal	Located at bridge ends of both approach slabs. Losing adhesion in spots and needs resealed (2013). Roadway forward of approach slab has a 4' x 6' broken slab of pavement that pumps when trucks cross it.
308/1	Constr Non Exp Jt	Located at piers, and between approach slabs and abutments. Tar sealed. Minor leakage at ends at piers in past, but now resealed.
321/1	R/Conc Approach Slab	Short light random cracks.

Colorado Department of Transportation
Structure Inspection and Inventory Report (English Units)

Highway Number (ON) 5D: 025A _

Mile Post (ON)11: 259.254 mi

Elem/Env	Description	Element Notes
325/1	Slope Prot/Berms	Very steep. Concrete slope paving at both abutments. Light horiz. cracks in some panels. Pedestrian path (8½ ft. wide) and retaining wall (about 3 ft. high) at toe of both slopes (constructed prior to 2011 inspection).
326/1	Bridge Wingwalls	Stubs. Look OK. Minor erosion behind #4R.
334/1	Metal Rail Coated	Galvanized Type W bridge rail. Flex-beam portion of left rail is dented in spots from traffic impact above Spans 2 & 3.
338/1	Conc Curbs/SW	Light trans. cracks and some map cracking on top face.
340/1	Superstr Cnc Coating	On exterior girders, overhangs, and curbs. Looks good.
341/1	Substr Conc Coating	On abutments, wingwalls, pier columns, pier caps, and slope paving. Failing at column bases.
359/1	Soffit Smart Flag	Overhangs have some water staining under pier joints. Some spalls with exposed rebar at exterior edges of deck.

Maintenance Activity Summary

MMS Activity	Description	Recommended	Status	Target Year	Est Cost
353.04	Br Dk Rpr	5/18/2009	-1	2015	750

Patch the spalls (potholes) in deck surface along Pier 3 joint.

Bridge Notes

Narrow lanes and very heavy traffic on Co. Rd. 26 (Crossroads Blvd.) under structure.
 Metal conduit along Abutment 1 and Girder 3C.
 Paint on 43" pedestrian railing below structure along sidewalks is failing.

Colorado Department of Transportation
Structure Inspection and Inventory Report (English Units)

Highway Number (ON) 5D: 025A _

Mile Post (ON)11: 259.254 mi

Inspection Notes

Temperature: 80°
Time: 3:00
Weather: Partly Cloudy

Scope:

NBI: Element: Underwater: Fracture Critical: Other: Type: Regular NBI

Team Leader Inspection Check-off:

FCM's Vertical Clearance
 Posting Signs Stream Bed Profile
 Essential Repair Verification

Inspection Team:

Inspection Date: 05/13/2013

Inspector: JACKSONC

Inspector (Team Leader)

Colorado Department of Transportation
Structure Inspection and Inventory Report (English Units)

Highway Number (ON) 5D: 025A
 Mile Post (ON)11: 259.255 mi

Bridge Name: C-17-ET Inspection Date: 5/13/2013 Sufficiency Rating: 82.1 FO

NBI Reporting ID:	C-17-ET
Rgn/Sectn 2E/2M:	41
Trans Region 2T	03
County Code 3:	069
LARIMER	
Place Code 4:	46465
LOVELAND	
Rte.(On/Under)5A:	1
Signing Prefix 5B:	1
Level of Service 5C:	1
Directional Suffix 5E:	0
Feature Intersected 6:	
CROSSROADS BLVD.	
Facility Carried 7:	
25 ML SBND	
Alias Str No.8A:	
Pril Str No. 8P	
C-17-ES	
Location 9:	
2 MI N OF LOVELAND / US34	
Max Clr 10:	328.1 ft
BaseHiway Net12:	1
IrsinvRout 13A	000000025A
IrrsubRout No13B:	00
Latitude 16:	40d 26' 08"
Longitude 17:	104d 59' 31"
Range18A:	68 W
Township18B:	68
Section18C:	34
Detour Length 19:	0.0 mi
Toll Facility 20:	3
Custodian 21:	1
Owner 22:	1
Functional Class 26:	11
Year Built 27:	1965
Lanes on 28A:	2
Lanes Under 28B:	2
ADT 29:	35,600
Year of ADT 30:	2007
Design Load 31:	5
Apr Rdwy Width 32:	38.0 ft
Median 33:	1
Skew 34:	0.00 °
Structure Flared 35:	1
Sfty Rail 36a/b/c/d:	1 0 1 1
Rail ht36h:	32 "in"

Hist Signif 37:	5
Posting status 41:	A
Service on/un 42A/B:	6 1
Main Mat/Desgn 43A/B:	1 4
Appr Mat/Desgn 44A/B:	0 0
Main Spans Unit 45:	3
Approach Spans 46:	0
Horiz Clr 47:	38.0 ft
Max Span 48:	29.5 ft
Str Length 49:	94.0 ft
Curb Wdth L/R 50A/B:	0.0 ft 0.0 ft
Width Curb to Curb 51	38.0 ft
Width Out to Out 52:	42.0 ft
Deck Area:	3,950.4 sq. ft
Min Clr Ovr Brgd 53:	99.99
Min Undrclr Ref 54A:	H
Min Undrclr 54B:	16.0 ft
Min Lat Clrnce Ref R 55A:	H
Min Lat Undrclr R 55B:	2.0 ft
Min Lat Undrclr L 56:	0.0 ft
Deck 58:	6
Super 59:	5
Sub 60:	5
Channel/Protection 61:	N
Culvert 62:	N
Optprtng Rtg Method 63:	1 LF Load Factr
Operating Rating 64:	55.8
Inv Rtgng Method 65:	1
Inventory Rating 66:	33.5
Asph/Fill Thick 66T:	000 "in"
Str. Evaluation 67:	5
Deck Geometry 68:	6
Undrclr Vert/Hor 69:	3
Posting 70:	5
Waterway Adequacy 7	N
Approach Alignment 72:	8
Type of Work 75A:	
Work Done By 75B:	
Length of Improvment 76:	0.0 ft
Insp Team Indicator 90B:	RED TEAM
Inspector Name 90C:	TATALASKIT
Frequency 91:	24 months
FC Frequency 92A:	
UW Frequency 92B:	
SI Frequency 92C:	
FC Inspection Date 93A:	

UW Inspection Date 93B	
SI Date 93C:	
Bridge Cost 94:	\$ 0
Roadway Cost 95:	\$ 0
Total Cost 96:	\$ 0
Year of Cost Estimate 97:	
Brdr Brgd Code/% 98A/B:	
Border Bridge Number 99:	
Defense Highway 100:	1
Parallel Structure 101:	L
Direction of Traffic 102:	1
Temporary Structure 103	
Highway System 104:	1
Fed Lands Hiway 105:	0
Year Reconstructed 106	0000
Deck Type 107:	1
Wearing Surface 108A	1
Membrane 108B:	0
Deck Protection 108C:	0
Truck ADT 109:	12 %
Trk Net 110:	1
Pier Protection 111:	
NBIS Length 112:	Y
Scour Critical 113:	N
Scour Watch 113M:	
Future ADT 114:	54,112
Year of Future ADT 115	2027
CDOT Str Type 120A:	CSG
CDOT Constr Type 120B	2.
Inspection Indic 122A:	
Inspection Trip 122AA	
Inspection Schedule ID:	ODD MAY F11
Maintenance Patrol 123:	50
Expansion Dev/Type124	0
Brdg Rail Type/Mod 125A/B	W 0
Posting Trucks 129A/B/C	0 0 0
Str Rating Date 130:	6/27/2006
Special Equip 133:	-1
Vert Clr N/E 134A/B/C:	X 99.99 0
Vert Clr S/W 135A/B/C	X 99.99 0
Vertical Clr Date:	5/23/2011
Weight Limit Color: 139	0
Str Billing Type:	U
Userkey 1 - System:	ONSYS
Userkey 7-Update Indic	

Inspector Name: TATALASKIT

Colorado Department of Transportation
Structure Inspection and Inventory Report (English Units)

Highway Number (ON) 5D: 025A

Mile Post (ON)11: 259.255 mi

Element Inspection Report

Elm/En	Description	Units	Total Qty	% in 1	CS 1	% in 2	CS 2	% in 3	CS 3	% in 4	CS 4	% in 5	CS 5
12/1	Bare Concrete Deck	(SF)	3,948	0 %	0	100 %	3,948	0 %	0	0 %	0	0 %	0
110/1	R/Conc Open Girder	(LF)	460	97 %	444	2 %	10	1 %	6	0 %	0	0 %	0
205/1	R/Conc Column	(EA)	6	67 %	4	33 %	2	0 %	0	0 %	0	0 %	0
215/1	R/Conc Abutment	(LF)	84	0 %	0	50 %	42	50 %	42	0 %	0	0 %	0
234/1	R/Conc Cap	(LF)	76	86 %	65	13 %	10	1 %	1	0 %	0	0 %	0
306/1	Asphaltic Plg Exp Jt	(LF)	42	100 %	42	0 %	0	0 %	0	0 %	0	0 %	0
308/1	Constr Non Exp Jt	(LF)	168	96 %	162	4 %	6	0 %	0	0 %	0	0 %	0
321/1	R/Conc Approach Slab	(EA)	2	100 %	2	0 %	0	0 %	0	0 %	0	0 %	0
325/1	Slope Prot/Berms	(EA)	2	100 %	2	0 %	0	0 %	0	0 %	0	0 %	0
326/1	Bridge Wingwalls	(EA)	4	100 %	4	0 %	0	0 %	0	0 %	0	0 %	0
334/1	Metal Rail Coated	(LF)	188	100 %	188	0 %	0	0 %	0	0 %	0	0 %	0
338/1	Conc Curbs/SW	(LF)	188	89 %	168	9 %	16	2 %	4	0 %	0	0 %	0
340/1	Superstr Cnc Coating	(EA)	1	100 %	1	0 %	0	0 %	0	0 %	0	0 %	0
341/1	Substr Conc Coating	(EA)	1	100 %	1	0 %	0	0 %	0	0 %	0	0 %	0
358/1	Deck Cracking SmFlag	(EA)	1	100 %	1	0 %	0	0 %	0	0 %	0	0 %	0
359/1	Soffit Smart Flag	(EA)	1	100 %	1	0 %	0	0 %	0	0 %	0	0 %	0
362/1	Traf Impact SmFlag	(EA)	8	0 %	0	100 %	8	0 %	0	0 %	0	0 %	0

Elem/Env	Description	Element Notes
12/1	Bare Concrete Deck	Concrete deck - transversely tined - Longitudinal, transverse and random cracks throughout; most have been sealed. One concrete patch near A1. Two newer concrete patches in ML #1 at P2, but breaking up. See 2013 Sketch.
110/1	R/Conc Open Girder	All span 2 girders hit by high loads in each direction (EB and WB), see 5-2009 PHOTOS and #362 for descriptions. Some thin patches. Diagonal cracks at bearing areas in Girders 2A, 2E, 3A, and 3E at P3; Girders 1A & 1E at P2; SEE 1993 PHOTO. Typical light vertical flexure cracks in all.
205/1	R/Conc Column	Some light horizontal cracks. Moderate delam. cracks near grade line of Columns 3A, and 3B.
215/1	R/Conc Abutment	Diagonal and vertical cracks with light scale and heavy efflor. throughout both walls; 5-2009 PHOTOS. A1 left side pile is exposed due to erosion trough, 5-2009 PHOTO. New slope pave has covered up erosion and exposed pile.

Colorado Department of Transportation
Structure Inspection and Inventory Report (English Units)

Highway Number (ON) 5D: 025A _

Mile Post (ON)11: 259.255 mi

Elem/Env	Description	Element Notes
234/1	R/Conc Cap	Left end of P2, and both ends P3 have light delam. cracks and/or spalls generally less than 1 s.f.. Left end of P2 has a spall with exposed rebar; 7 inches x 3 inches; P3 Rt. has 12 inches x 4 inches. Delam. cracking below Girders 1C, 1D, & 1E at P2, and Girders 3B & 3C at P3 (PHOTO 5/13).
306/1	Asphaltic Plg Exp Jt	Newer and just beyond Abut. 4 appr. slab. Looks good.
308/1	Constr Non Exp Jt	Tar seal at deck joints above piers and abutments, fair condition; appears to be functioning. One concrete patch near A1, 8 square feet in area. Two newer concrete patches in ML #1 at P2, but breaking up. See 2013 Sketch and PHOTO.
321/1	R/Conc Approach Slab	Newer overlay. Raveling of asphalt in Lt. shoulder stripe at A1.
325/1	Slope Prot/Berms	TNew slope pave at both abuts that has a 4 ft. high retaining wall with sidewalks and ped rail. See 5/23/2011 elev. PHOTOS.
326/1	Bridge Wingwalls	Stub wings, OK. Some minor cracks in A4 left. Mod. crack at end of #1 Lt. at A1.
334/1	Metal Rail Coated	Galvanized Type W rail. Flex beam scraped on Rt. rail above P3, otherwise good cond.
338/1	Conc Curbs/SW	Contaminated shrinkage cracks at all ends, moderate at right rear. Left exterior side near A1 has 2 small spalls with exposed rebar.
340/1	Superstr Cnc Coating	Ext. Girders, columns and pier caps. Look good
341/1	Substr Conc Coating	Slope pave and wing walls. Looks good.
358/1	Deck Cracking SmFlag	See element 12.
359/1	Soffit Smart Flag	Light diagonal cracks with efflor. at corners. Some delam. cracking along Lt. overhang, esp. near piers.
362/1	Traf Impact SmFlag	All span 2 girders hit by high load (SEE 1997 & 2009 PHOTOS) above E.B. and W.B. lanes: (spall dimensions in inches) Gir. 2A above EB (18 L x 12 up x 12 across bottom x 2.5 dp with exposed rebar); 2A WB 3 nicks; 2B has a nick for EB & WB; 2C EB (15 x 6 up x 12 across bottom x 2 dp with exposed rebar); nick on both edges WB; 2D EB has a nick & 1.5 dp gouge on edges; WB chipped; 2E EB (24 x 8 up x 6 across bottom with exposed rebar)

Maintenance Activity Summary

MMS Activity	Description	Recommended Status	Target Year	Est Cost
358.00	Substr	5/13/2013	2015	1000

Repatch the concrete patches along Pier 2 that are breaking up.

Colorado Department of Transportation
Structure Inspection and Inventory Report (English Units)

Highway Number (ON) 5D: 025A _

Mile Post (ON)11: 259.255 mi

Maintenance Activity Summary

MMS Activity	Description	Recommended	Status	Target Year	Est Cost
354.01	Suprstr	5/4/2003	-1	2015	3000

Patch spalls in concrete girders in Span 2 which have been hit by high loads.

Bridge Notes

UTILITIES: 1 inch conduit on ext web Girders 2A, and 3A.
Bridge has had new pedestrian walks and slope pave placed prior to 2011 inspection, and probably will not be replaced due to recent work done on bridge.

Colorado Department of Transportation
Structure Inspection and Inventory Report (English Units)

Highway Number (ON) 5D: 025A _

Mile Post (ON)11: 259.255 mi

Inspection Notes

Time: 2:55 Temperature: 85 Degrees Weather: P/C Team Leader: TAT

Scope:

NBI: Element: Underwater: Fracture Critical: Other: Type: Regular NBI

Team Leader Inspection Check-off:

- FCM's
- Posting Signs
- Essential Repair Verification
- Vertical Clearance
- Stream Bed Profile

Inspection Team:

Inspection Date: 05/13/2013

Inspector: TATALASKIT

Inspector (Team Leader)

Appendix B

*Draft I-25 Corridor Common Structural Elements and
Design Criteria for the Preparation of Site-Specific
Structure Selection Reports, May 2013*

Draft I-25 Corridor Common Structural Elements and Design Criteria for the Preparation of Site-Specific Structure Selection Reports

North I-25 Reconstruction

CDOT Region 4



May 2013

List of Preparers

Name	Organization
<p>James Flohr, Resident Engineer James Usher, PM for State Highway (SH) 66 to SH 56 Rich Christy, PM for U.S. Highway (US) 34 Interchange Shar Shadowen, PM for SH 392 to SH 14</p>	 <p>DEPARTMENT OF TRANSPORTATION</p>
<p>Matt Gilbert Tsiouvaras Simmons Holderness 5690 DTC, Level 3, Suite 345@ Greenwood Village, CO 80111</p>	 <p>CONSULTING ENGINEERS</p>
<p>Jeff Mehle and Greg Dreeszen Jacobs 707 17th Street, Suite 2300 Denver, CO 80202</p>	
<p>Gary Maji AECOM 717 17th Street, Suite 2600 Denver, CO 80202</p>	
<p>Cindy Otegui Felsburg Holt & Ullevig 6300 S. Syracuse Way, Suite 600 Centennial, CO 80111</p>	
<p>Martin Merklinger RockSol 6510 W 91st Avenue, Suite 130 Westminster, CO 80031</p>	
<p>Ken Saindon Atkins 4601 DTC Blvd, Suite 700 Denver, CO 80237</p>	

Table of contents

Chapter	Pages
1. Introduction	1
2. Structure aesthetics	2
2.1. Structures over I-25	2
2.2. I-25 over state highways and county roads	6
2.3. I-25 over drainage features	12
2.4. Atypical bridges	13
2.5. Retaining walls	15
3. Base structure alternatives	16
3.1. Structures over I-25	16
3.2. Structure alternatives: I-25 over state highways, county roads, and drainage features	22
3.3. Structure layout and type: atypical bridges	30
3.4. Retaining walls	31
4. Accelerated bridge construction considerations	45
4.1. Implementation	46
5. Structures design criteria	48
5.1. Design specifications	48
5.2. Design method	48
5.3. Rating method	48
5.4. Design loads	48
5.5. Materials	49
5.6. Safety specifications	49
5.7. Life cycle cost analysis	49
6. Common bridge maintenance items	50
6.1. Bridge deck drains	50
6.2. Bridge approach drains	50
6.3. Bridge rail – duplex coating	50
6.4. Fencing	50
6.5. Anti-icing systems	51
6.6. Bridge deck durability	51
6.7. Expansion joints	51
6.8. Bearings	51
6.9. Access hatches	51
6.10. Under-bridge lighting	51
6.11. Electrical conduit in bridge rails	51
6.12. Sidewalk curbs and treatments	51
6.13. Barrier separations for pedestrians	52
6.14. Stain versus coating	52
6.15. Color theme	52
Appendix A. North I-25 Structure Inventory	A
Appendix B. North I-25 Structural Common Maintenance Items Plans and Specifications	B
Appendix C. Bridges over I-25 Structure Alternatives Cost Estimates	C
Appendix D. North I-25 Representative Site-specific Structure Selection Report	D
Appendix E. Reference Documents	E

Tables

Table 2.1	North I-25 atypical bridges.....	13
Table 3.1	Bridges over I-25	17
Table 3.2	I-25 bridges over rural roads	22
Table 3.3	I-25 bridges over urban roads	23
Table 3.4	I-25 bridges over interchange locations	24
Table 3.5	I-25 bridges over drainage features.....	26
Table 4.1	Baseline ABC criteria and components for evaluation	47
Table 6.1	Base standard color palette	52

Figures

Figure 2.1	Typical I-25 cross section	2
Figure 2.2	Typical bridge over I-25 span configuration	2
Figure 2.3	Edge of deck/overhang treatments for bridges over I-25	3
Figure 2.4	Abutment slope typical section for bridges over I-25	4
Figure 2.5	Plan view of tiered abutment walls and abutment slope for bridges over I-25.....	4
Figure 2.6	Existing and proposed pier column sections and elevations for bridges over I-25	5
Figure 2.7	Example of baseline corridor aesthetics	6
Figure 2.8	Edge of deck/overhang treatments for bridges carrying I-25 with side-by-side girder configurations	7
Figure 2.9	Example of I-25 median access between bridges at WCR 20	7
Figure 2.10	Tiered wall section example	8
Figure 2.11	Example of MSE retaining wall in front of abutments.....	9
Figure 2.12	Example of wingwall elevation.....	10
Figure 2.13	Example of base corridor pier aesthetic details	10
Figure 3.1	East Prospect Road typical section	16
Figure 3.2	Bridges over I-25 option evaluation	19
Figure 3.3	Typical I-25 cross section – SH 14 to SH 66	22
Figure 3.4	Rural road typical sections	23
Figure 3.5	Recommended urban road typical section for single-span configuration	24
Figure 3.6	Recommended urban road typical section for two-span configuration.....	24
Figure 3.7	Recommended interchange typical section for two-span configuration	25
Figure 3.8	Recommended interchange typical section for three-span configuration	25
Figure 3.9	Superstructure selection matrix	28
Figure 3.10	Fill configuration retaining wall typical section, supporting roadway	31
Figure 3.11	Fill configuration retaining wall typical section, not at roadway edge	32
Figure 3.12	Cut configuration retaining wall typical section at base of slope	32
Figure 3.13	Cut configuration retaining wall typical section at top of slope	33
Figure 3.14	MSE wall with precast concrete face	38
Figure 3.15	MSE wall with precast concrete face monitored time-consolidation.....	41
Figure 3.16	MSE wall with precast concrete face with foundation improvement.....	42
Figure 3.17	Multi-anchor-facing soil nail retaining wall with precast concrete face	44
Figure 4.1	Potential ABC technologies or methods	46

Acronyms

AASHTO	American Association of State Highway and Transportation Officials
ABC	accelerated bridge construction
ADA	Americans with Disabilities Act
ADT	average daily traffic
AHP	Analytic Hierarchy Process
AREMA	American Railway Engineering and Maintenance-of-Way Association
BDM	Bridge Design Manual
BT	Bulb-T
CDOT	Colorado Department of Transportation
EB	eastbound
FEIS	Final Environmental Impact Statement
FHWA	Federal Highway Administration
FIR	field inspection review
FOR	final office review
GWR	Great Western Railway
I-25	Interstate 25
ksf	kips per square foot
ksi	kips per square inch
lb/LF	lbs per linear foot
LCR	Larimer County Road
LRFD	AASHTO LRFD Bridge Design Specifications
MOT	maintenance of traffic
mph	miles per hour
MSE	mechanically stabilized earth
NB	northbound
psi	lbs per square inch
ROD	Record of Decision
SB	southbound
Sd1	site factor
SH	State Highway
SPUI	single-point urban interchange
UPRR	Union Pacific railroad
US 34	U.S. Highway 34
WB	westbound
WCR	Weld County Road

1. Introduction

This report was developed as a joint effort between the Colorado Department of Transportation (CDOT) and the design consultant teams contracted by CDOT on the North Interstate 25 (I-25) project. The following projects are part of the North I-25 project:

- State Highway (SH) 66 to SH 56, CDOT #18319;
- U.S. Highway (US) 34 Interchange, CDOT #18844; and
- SH 392 to SH 14, CDOT #18357.

Structures covered by this report include bridges and walls identified in the North I-25 Final Environmental Impact Statement (FEIS) Phase 1 Record of Decision (ROD) for the above mentioned projects. A list of existing structures and proposed structures included in this corridor is in Appendix A of this report. The FEIS ROD covers I-25 from 120th Avenue to north of SH 14.

The purpose of this report is to provide the following:

- Document the aesthetic criteria for all new bridges and retaining walls proposed along the corridor including bridges going over I-25, bridges carrying I-25 over various features, and retaining walls required as a result of the improvements to I-25.
- Establish the structural design criteria for all new bridges, box culverts, and retaining walls along the corridor.
- Provide standardized details that supplement the CDOT bridge standard drawings or, where multiple standards exist, identifying a common detail to be used.
- Streamline the identification of a recommended structure type in site-specific structure selection reports for structures that are required to have a type selection report by the *CDOT Bridge Design Manual* (BDM).

This report is not intended to take the place of site-specific structure selection reports. It is intended that when the provisions outlined in this report are used for a specific structure, the site-specific report will reference the sections of this report that apply. When provisions in this report are impossible to accommodate, or prove to be cost prohibitive for a proposed structure, the site-specific structure selection report for said structure will document any deviations from this report and will be subject to CDOT approval.

2. Structure aesthetics

This section is provided to give designers the architectural requirements for bridges and retaining walls along the North I-25 corridor which may influence the structure layout or structure type selection.

2.1. Structures over I-25

Structures that carry features over I-25 will have the following common elements along the North I-25 corridor. In lieu of site-specific aesthetic criteria, this information is provided as the baseline aesthetic requirement.

2.1.1. Span configuration

Three structures exist along the corridor that exemplify the preferred standard for structures over North I-25. These three bridges are Weld County Road (WCR) 8 over I-25, SH 52 over I-25, and SH 66 over I-25, which were designed to span over the ultimate I-25 cross section without the use of piers in the median while using a three-span configuration. The short end spans coupled with the clear span of the highway creates an open, uncluttered view for the drivers along I-25.

The North I-25 FEIS ROD echoed this methodology by limiting the use of piers in the median of I-25. While acknowledging that several current bridges and proposed future structures in the corridor have or may require piers in the median, all proposed structures will clear span the ultimate I-25 cross section unless placement of piers in the medians is approved by CDOT.

The North I-25 FEIS ROD identified a Preferred Alternative for the typical I-25 cross section with an edge-of-pavement to edge-of-pavement section of 184 feet (See Figure 2.1). Placing Guardrail Type 7 (Style CA) (1-foot 11-inch width) and a 3-inch allowance for forming the rail between the shoulder and the piers on either side of the highway creates a minimum required clear span of 188 feet 4 inches (see Figure 2.2).

Figure 2.1 Typical I-25 cross section

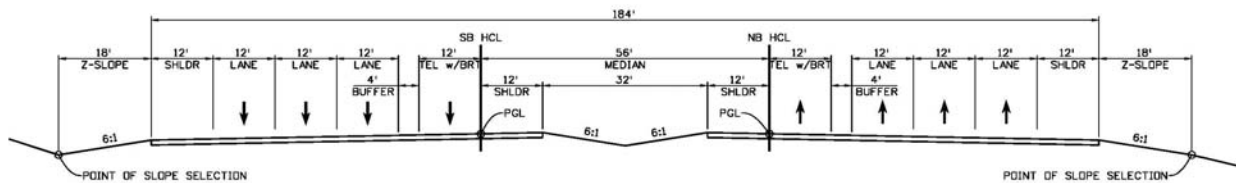
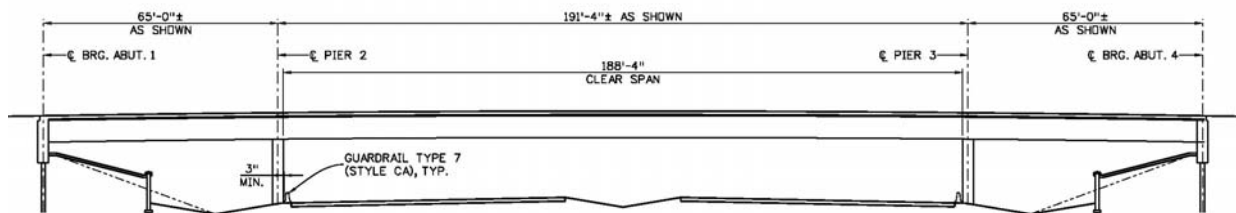

Figure 2.2 Typical bridge over I-25 span configuration



The end span lengths are a function of the fill slopes at the abutments, drainage ditches and features necessary for water quality, and structural requirements such as uplift concerns at abutments. The end span (centerline of bearing at the abutment to centerline of pier) of the current standard three span structures is 65 feet, but span lengths for end spans shall be governed by design and site conditions.

Unless site-specific constraints require a different arrangement, the recommended span configuration for bridges over I-25 is as shown in Figure 2.2.

2.1.2. Exterior girder appearance and girder shape

The standard structures over I-25 use a tub or box girder shape. To maintain this consistency, the exterior girder shape for new structures over I-25 will be tub or box shaped.

2.1.3. Bridge deck overhang lengths

Bridge deck overhangs should be maximized to create shadow patterns on the superstructure, which visually reduces the structure's depth. The CDOT BDM provides guidance for the maximum overhangs of various girder types. These values were developed to limit potential construction problems; however, several structures have been constructed with larger overhangs with CDOT Staff Bridge approval. The guidance provided in the CDOT Bridge Design Manual will serve as the minimum overhang length and will be increased where possible with CDOT Staff Bridge approval. See Figure 2.3 for overhang and edge of deck treatments.

Figure 2.3 Edge of deck/overhang treatments for bridges over I-25

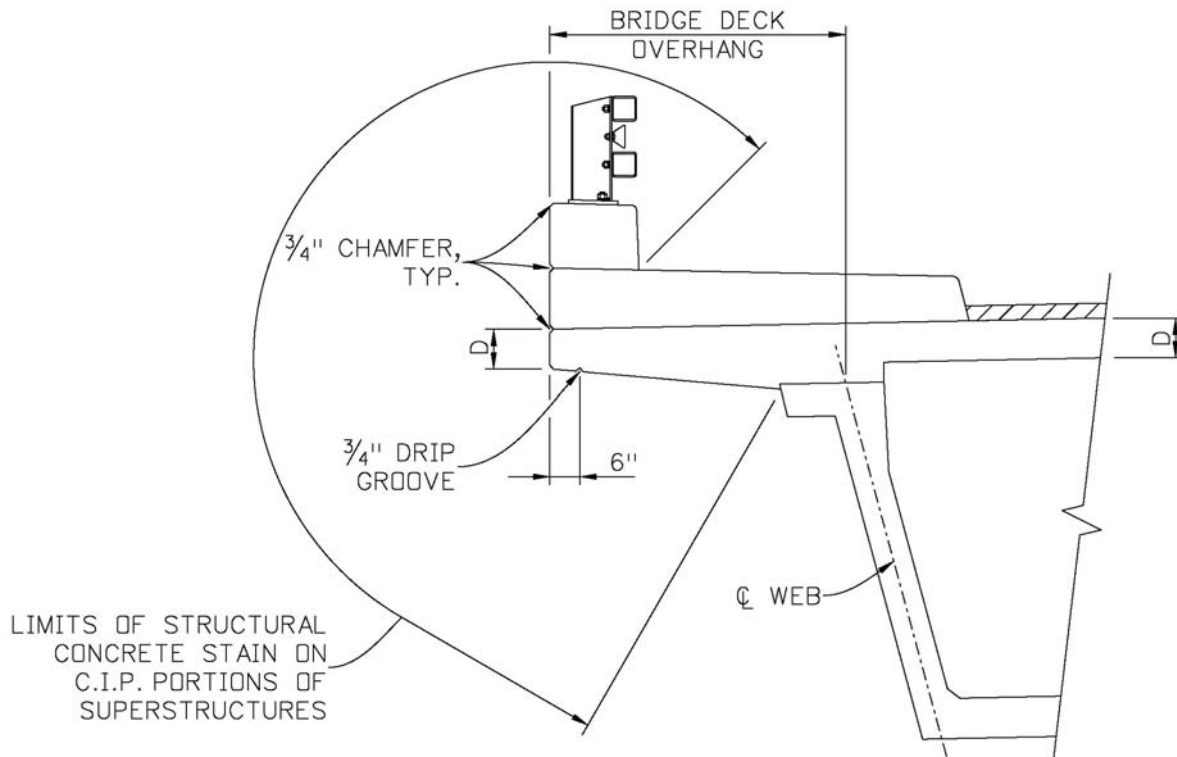

2.1.4. Abutment slopes

Along the I-25 corridor, slopes adjacent to abutments consist of tiered, block-faced mechanically stabilized earth (MSE) walls, concrete walls with a split-faced block formliner, or modular block walls, which take the place of 2:1 paved slopes for easier maintenance and improved aesthetics. The walls will have a maximum fill slope of 4:1 and incorporate an 8-inch top layer of median cover material (stone) over geotextile between tiers of walls and between walls and abutments. These wall and slope configurations will be used to maintain corridor consistency. Figure 2.4 shows a typical section of an abutment slope.

Figure 2.4 Abutment slope typical section for bridges over I-25

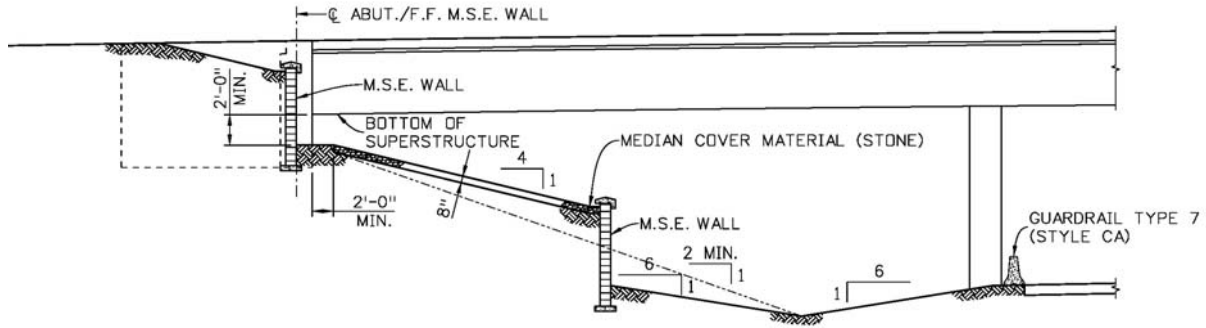

2.1.5. Abutments and wingwall treatments

CDOT requires a 2-foot-high minimum exposed abutment at the front face and a 2-foot-wide soil bench for inspection purposes. This standard is consistent throughout the corridor and will be the minimum exposed height and bench widths for abutments. The maximum exposed abutment height below bearing seats will be 4 feet 0 inch unless larger heights are approved by CDOT. Abutments will have vertical faces and receive a Class 1 finish.

The three standard structures have cast-in-place wingwalls that are parallel to the overcrossing roadway. In front of these concrete wingwalls are tiered block-faced MSE or gravity walls that start at the abutment diaphragm, parallel to the abutment, and horizontally curve to become parallel to the overcrossing roadway at the end of the walls, as shown in Figure 2.5. This alignment and configuration will be maintained for consistency. Wingwalls will have vertical faces and will be aligned with the inside face of wingwalls matching the back face of bridge rails.

Figure 2.5 Plan view of tiered abutment walls and abutment slope for bridges over I-25

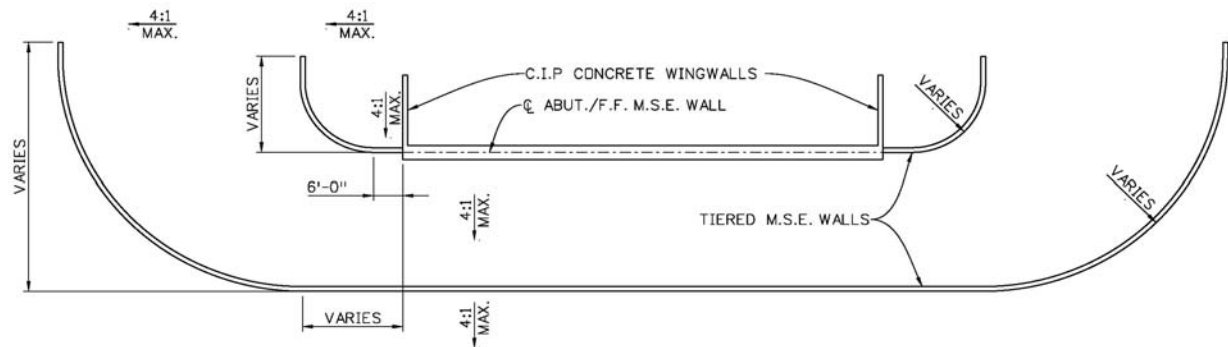

2.1.6. Pier type and shapes

Although the pier shape varies among the three standard structures, the configuration of the piers and number of columns is consistently a single column per girder line, with an integral pier diaphragm and without a dropped cap between columns. Columns at the SH 66 bridge are 4 feet 6 inch squares with a gothic pointed arch reveal set into the column. The 4-foot 6-inch wide columns match the width of the girder flange. Columns at the SH 52 and WCR 8 bridges are pill shaped and are 4 feet 0 inch wide by 2 feet 6 inches deep in the lower portion of the column with a +/- 7-foot-long transition to a 6-foot 6-inch-wide column at the girder bearing seat. The columns have vertical reveals that flare parallel with the column width transition at the top of columns. The 6-foot 6-inch width at the top of column columns matches the 6-foot 6-inch width of the girder flange.

To blend the different columns to best match both pier and column types along the corridor, a pill shaped column is the preferred type, with minimum dimensions of 5 feet 0 inch wide by 3 feet 0 inch deep with 1-foot 6-inch radius ends. A column will support each girder line. The columns are recommended to have two vertical reveals. See Figure 2.6 for a comparison of the different columns and reveals. Columns larger than the minimum will be permitted if necessary to resist vehicular collision (600 kip) impact loads.

Figure 2.6 Existing and proposed pier column sections and elevations for bridges over I-25

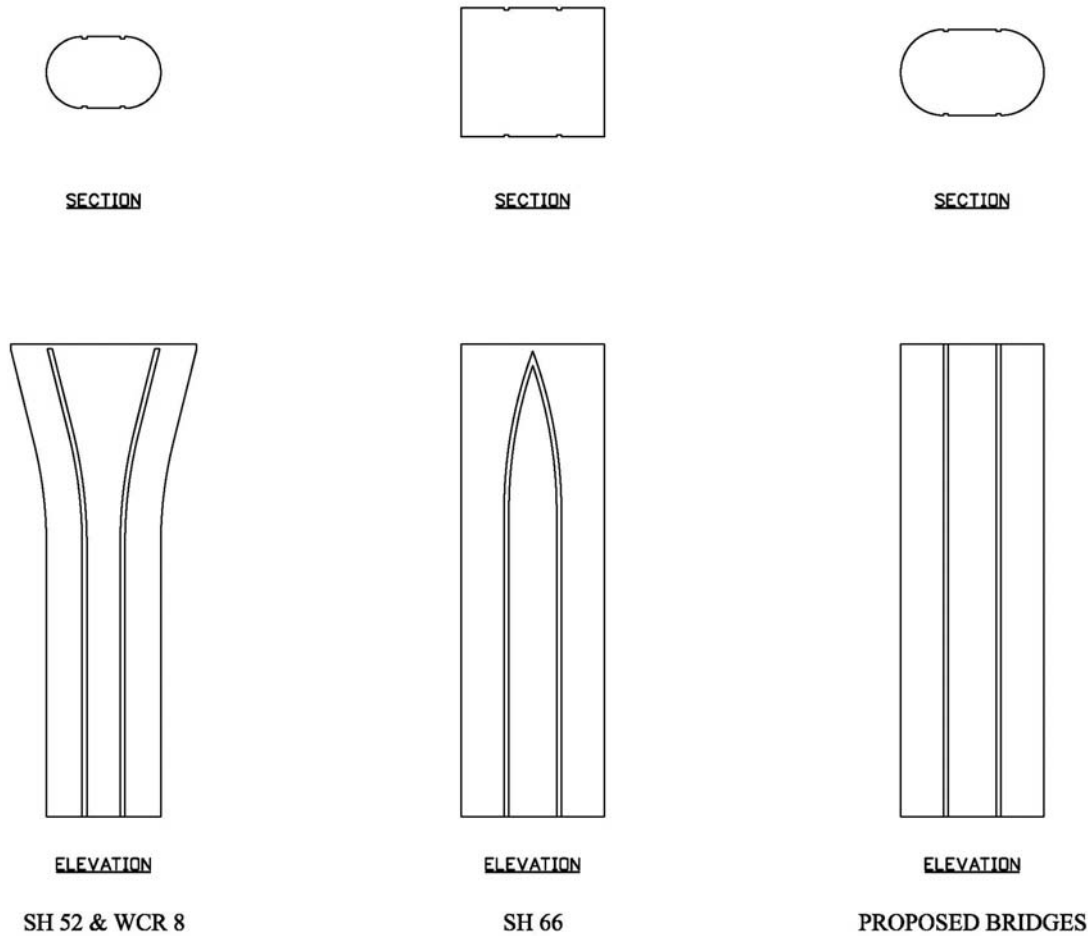

2.1.7. Bridge rails and fencing

Bridge rail will be CDOT type 10M steel rail, with duplex coating matching the colors identified in Section 6, Common Bridge Maintenance Items on concrete curb. Fencing will be attached to the type 10 rail and match the fencing identified in Section 6 of this report.

2.1.8. Bridge color treatments

Bridge color treatments will match those proposed throughout the corridor. Structural concrete coating will be applied to exposed surfaces of bridge rails, exterior edges of sidewalks, and decks as well as deck overhangs (as shown in Figure 2.3), exterior girder outside and exposed flanges, exposed bottom flanges on interior girders, abutments to 1 foot below grade, pier columns to 1 foot below grade, and wingwalls to 1 foot below grade. Coating limits on bridge rails will apply to railings on approach slabs. Colors for such coatings will match those found in Section 6, Common Bridge Maintenance Items.

2.2. I-25 over state highways and county roads

Aesthetic considerations for structures that will carry interstate traffic over other roadways will have many common elements along this corridor. In lieu of site-specific aesthetic criteria, this information is provided as the baseline aesthetic requirement. Figure 2.7 shows an example of the baseline requirements.

Figure 2.7 Example of baseline corridor aesthetics



2.2.1. Span configurations

The bridges can consist of one, two, or three spans and are dependent upon the roadway geometry and the available structure depth. The order of preference for the span configurations is:

- Single span
- Three span with clear span over roadway
- Two span with columns located in roadway median

2.2.2. Exterior girder appearance and girder shape

Girder types will depend upon the structure design. The overhang soffit, exterior face of girder, and bottom flange of the exterior girder will have a uniform concrete stain. Pier diaphragms shall match the girder shape on the exterior girders to give the appearance of a continuous superstructure. Edge of deck and overhang treatments will match those shown in Figure 2.3.

2.2.3. Bridge deck overhang lengths

Bridge overhangs will generally follow the CDOT BDM for length. For bridges that consist of spaced girders, the minimum deck overhang shall be 12 inches from the outside edge of exterior girder flanges and the minimum thickness of overhangs shall be 8 inches. In addition, a 0.75-inch drip groove located 6 inches from the edge of deck is recommended to limit water staining on the face of the exterior girders (see Figure 2.3). Overhangs in excess of those allowed by the BDM are allowed, but shall be approved by CDOT Staff Bridge. For bridges with girders in a side-by-side configuration, the maximum overhang will be sized to allow a #4 bar to project from the precast girder into the bridge rail section while meeting clearance requirements and allowing for construction tolerance (see Figure 2.8). The minimum overhang for bridges with girders in a side-by-side configuration is 9 inches. The deck thickness will be 8 inches at the edge of deck and have a 0.75-inch drip groove located 6 inches from the edge of deck.

Figure 2.8 Edge of deck/overhang treatments for bridges carrying I-25 with side-by-side girder configurations

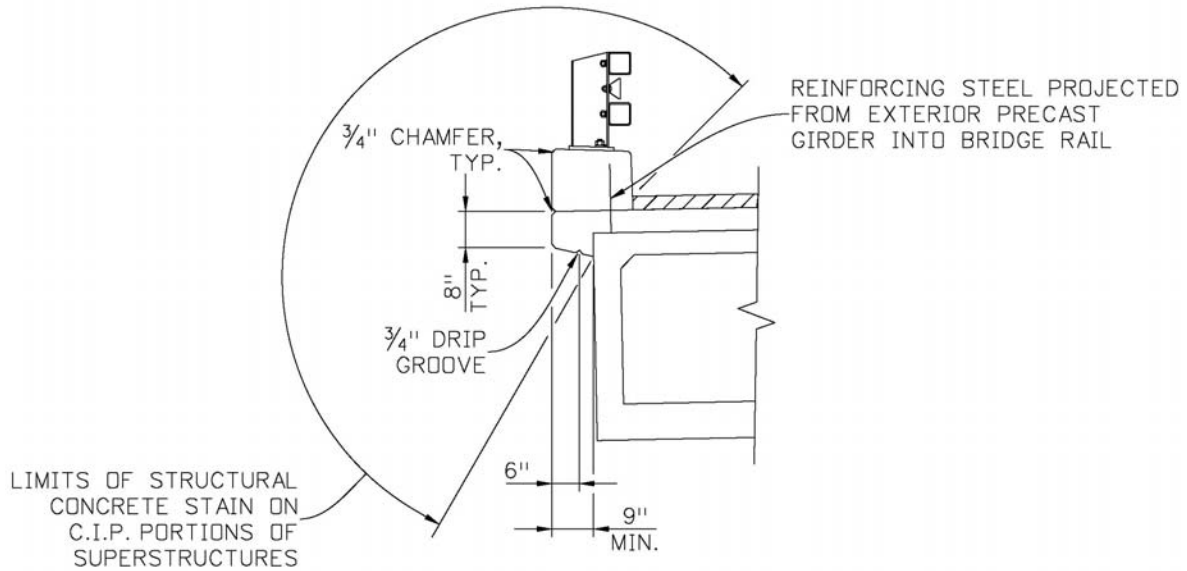

2.2.4. Abutment slopes

Options for the slopes from edge of pavement to the abutment face, in order of preference, are tiered walls, retaining walls, slope paving, and vertical walls. Walls when used, are recommended to be MSE walls. When MSE walls cannot to be used, gravity or semi-gravity walls should be used. The area between the bridges may be required to provide access to the I-25 medians as determined in the site-specific report. If access is required, the walls should allow for an access road and gates (see Figure 2.9).

Figure 2.9 Example of I-25 median access between bridges at WCR 20



2.2.4.1. Tiered walls

Tiered walls or retaining walls are recommended to support the area in front of the bridge abutments. The abutment slopes will generally consist of tiered block-faced MSE walls, concrete walls with a split-faced block formliner, or modular block walls, offset a distance of approximately 12 feet with a maximum slope of 4:1 and minimum slope of 8:1 between the walls. The exposed height of the individual walls should be not greater than 6 feet and not less than 3 feet. Tiered walls should have approximately equivalent exposed heights.

The slopes located above and below the walls will have an 8-inch top layer of median cover material over stone over geotextile. Sloped areas within the I-25 median between the bridges and along the sides of the bridges may have a 6-inch layer of median cover material (stone) over geotextile, as shown in Figure 2.10. The wall facing will be a textured block and have a beige color palette. A cast-in-place concrete cap overhangs the block.

Figure 2.10 Tiered wall section example

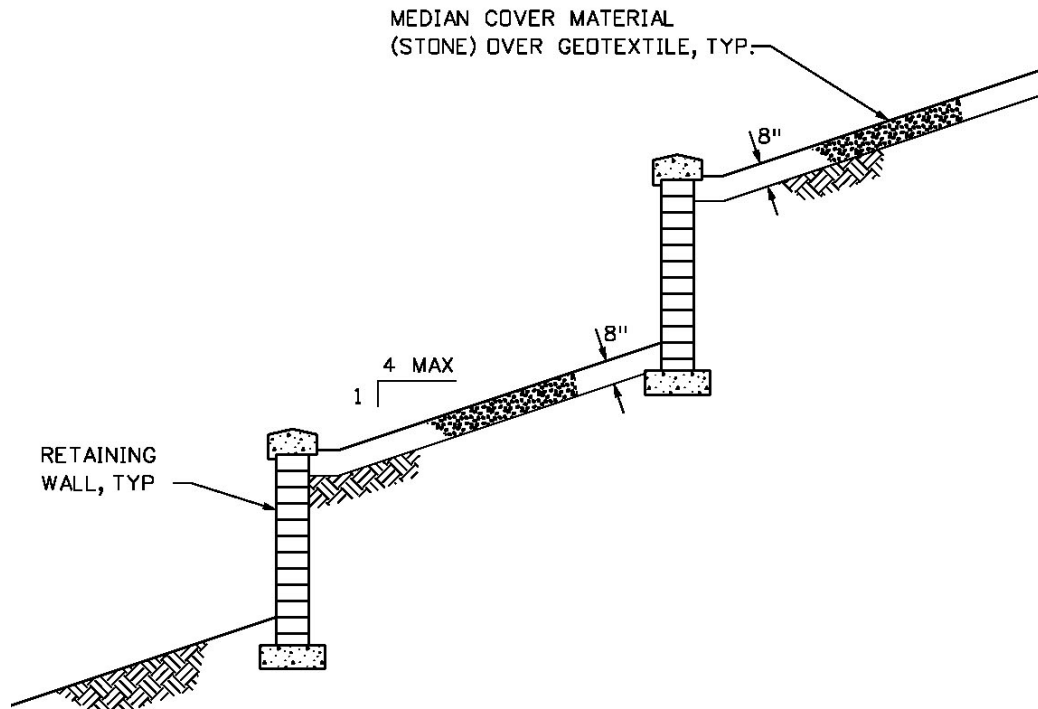

2.2.4.2. Retaining walls

Retaining may be used for structures crossing rural roads and when the geometry does not allow for tiered walls. Retaining walls should be located so that the reinforcing elements do not conflict with the bridge substructure and foundation. The slope between the abutment and retaining wall will have a maximum slope of 4:1 and minimum slope of 8:1 above, as shown in Figure 2.11. These slope limits apply below the wall as well. The exposed height of the individual walls should generally not be greater than 12 feet.

Figure 2.11 Example of MSE retaining wall in front of abutments

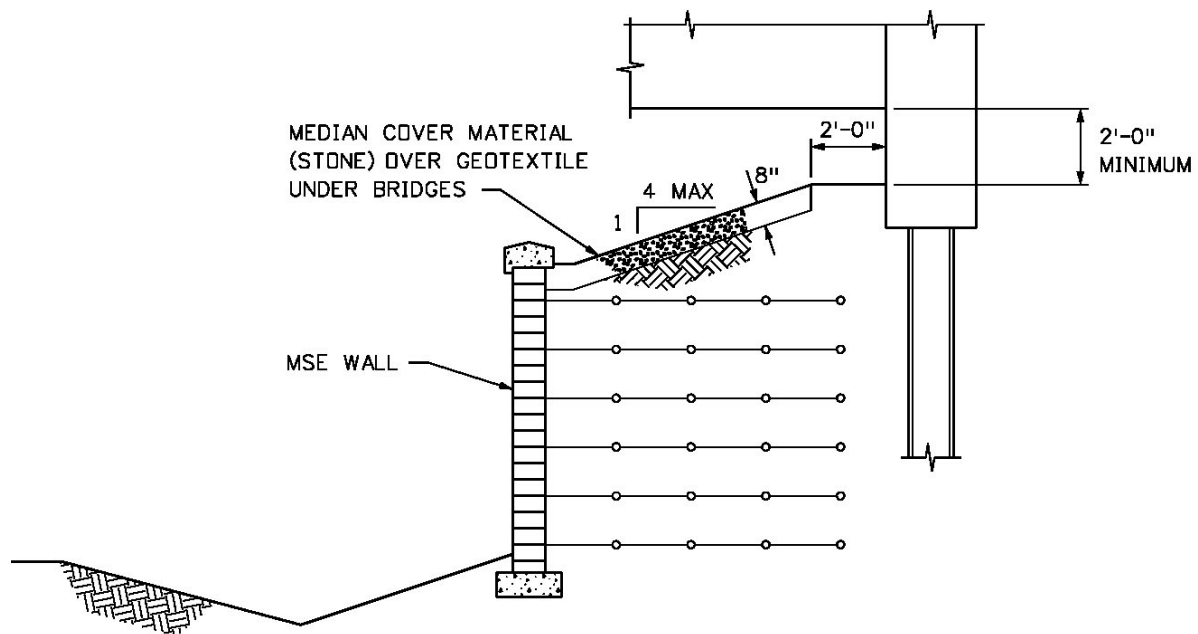

2.2.4.3. Vertical abutment walls

See Section 2.2.6, Abutments and Wingwall Treatments.

2.2.5. Median access

Median access from roads that cross below I-25 may be needed to provide maintenance via locking driveway gates and a gravel roadway. Wall layouts may be required to turn so that they will border the access road. The gravel access road width is 10 feet and has a maximum roadway grade of 6 percent. The driveway gates shall be per the CDOT Standard Plan No. M-607-1 with braced metal end posts, see Figure 2.9.

2.2.6. Abutments and wingwall treatments

The abutments will be constructed of smooth, cast-in-place concrete and have concrete stain applied on exposed surfaces to one foot below grade and be consistent with the corridor color palette as indicated in Section 6, Common Bridge Maintenance Items. The abutment walls will be vertical. The abutment exposed face shall not be less than 2 feet from the bottom of the superstructure and should not be more than 4 feet.

Tall abutment walls if implemented will be vertical. It is recommended that the vertical walls of tall vertical abutments have horizontal rustications cast into the abutments below the bridge and at the wingwalls. The rustication is recommended to be 3 feet 6 inches on center and be level along the face of the abutments and parallel to the bridge deck at the wingwalls. For more details about rustication, see Section 2.2.7, Pier Type and Shapes.

Abutments will use cast-in-place wingwalls that are parallel to I-25. Wingwalls will have vertical faces and match the height of the abutment plus the superstructure. The inside face of the wingwall will match the outside face of bridge rail on the approach slabs. See Figure 2.12 for elevation view of wingwalls.

Figure 2.12 Example of wingwall elevation

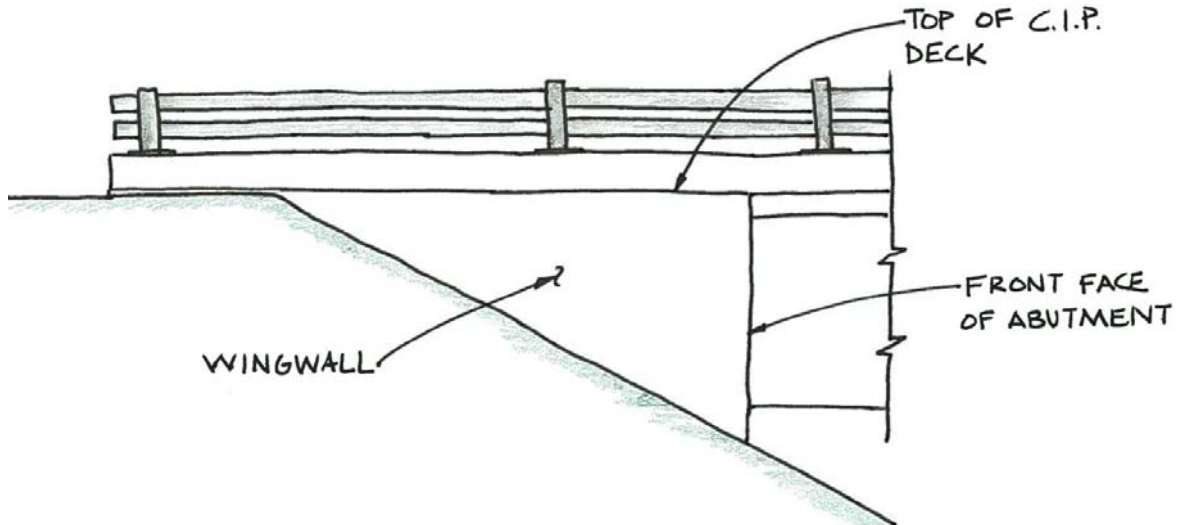

2.2.7. Pier type and shapes

For multi-span structures, the pier should consist of multiple columns that are evenly spaced. The pier cap shall be at least 1 foot wider than the columns. The depth should be minimized to create a more open and unobstructed view. The pier cap will have squared ends and provide a constant taper from the column face to the end of the pier cap, terminating in a square. The columns will be pill shaped and have a length between 8 feet (minimum) and 12 feet (maximum) and have radiused ends. Columns will have a horizontal (level) rustication at 3 feet 6 inches, center to center, and should be consistent in elevation within adjacent columns (see Figure 2.13). Rustication shall begin at 3 feet 6 inches below the highest point of the bottom of the pier cap. Rustication joints on all piers shall be terminated when the entire rustication would be beneath finished grade. Exposed concrete will be coated with a uniform concrete stain applied to all exposed surfaces to 1 foot below the adjacent finished grade.

Figure 2.13 Example of base corridor pier aesthetic details

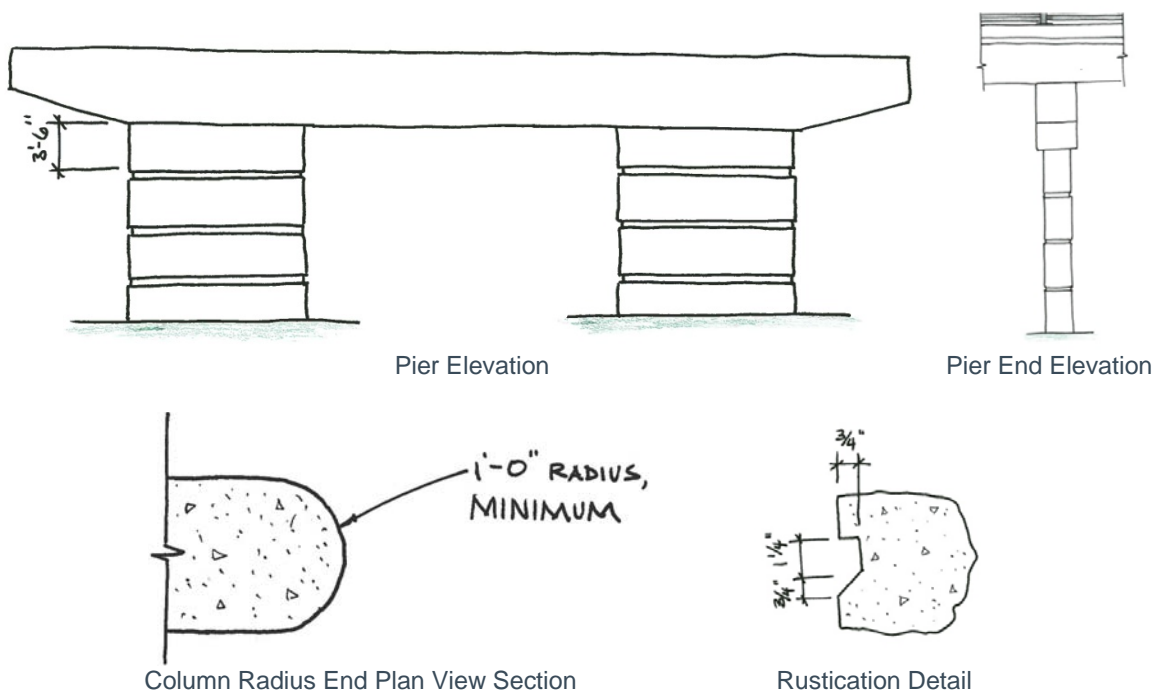

2.2.8. Bridge rail

The bridge rails will be Type 10M steel rail with duplex coating matching the colors identified in Section 6, Common Bridge Maintenance Items, on a concrete curb.

2.2.9. Bridge color treatments

Bridge color treatments shall match those proposed throughout the corridor. Structural concrete stain shall be applied to exposed surfaces of bridge rails, exterior edges of sidewalks and decks, deck overhangs, exterior girder outside and exposed flanges, exposed bottom flanges on interior girders, abutments to 1 foot below grade, pier columns to 1 foot below grade and wingwalls to 1 foot below grade. Stain limits on bridge rails shall apply to railings on approach slabs. Colors for such stains shall match those found in Section 6, Common Bridge Maintenance Items.

2.3. I-25 over drainage features

Structures that will carry interstate traffic over drainage features will have the following common elements along the corridor. In lieu of site-specific aesthetic criteria, this information is provided as the baseline aesthetic requirements.

2.3.1. Span configurations

The span configuration for structures over drainage features can consist of one or more spans, dependent upon the roadway geometry, hydraulic requirements, and the available structure depth.

2.3.2. Exterior girder appearance and girder shape

Girder type will depend upon the structure design. The overhang soffit, exterior face of girder, and bottom flange of the exterior girder will have a concrete stain applied per the corridor base color palette. See Section 6, Common Bridge Maintenance Items for stain colors and limits. Edge of deck and overhang treatments will match those shown in Figure 2.3.

2.3.3. Bridge deck overhang lengths

Bridge overhangs will generally follow the CDOT BDM for length. For bridges that consist of spaced girders, the minimum deck overhang shall be 12 inches from the outside edge of exterior girder flanges and the minimum thickness of overhangs shall be 8 inches. In addition, a 0.75-inch drip groove located 6 inches from the edge of deck is recommended to limit water staining on the face of the exterior girders (see Figure 2.3). Overhangs in excess of those allowed by the BDM are allowed, but shall be approved by CDOT Staff Bridge. For bridges with girders in a side-by-side configuration, the maximum overhang will be sized to allow a #4 bar to project from the precast girder into the bridge rail section while meeting clearance requirements and allowing for construction tolerance (see Figure 2.8). The minimum overhang for bridges with girders in a side-by-side configuration is 9 inches. The deck thickness will be 8 inches at the edge of deck and have a 0.75-inch drip groove located 6 inches from the edge of deck.

2.3.4. Abutment slopes

The slopes in front of the abutments will be dictated by the site geometric and hydrologic constraints. Slopes located under the bridge structures are recommended to have rip rap protection.

2.3.5. Abutments and wingwall treatments

The abutments and wingwalls will be constructed of smooth, cast-in-place concrete and have concrete stain applied on exposed surfaces to one foot below grade and be consistent with the corridor base color palette. The abutment walls will be vertical. The abutment exposed face shall not be less than 2 feet from the bottom of the superstructure. See Figure 2.12 for an example of wingwall elevation.

Tall abutment walls, if implemented, will be vertical. Where abutments can be viewed readily by the public, it is recommended that the vertical walls have horizontal rustications cast into the abutments below the bridge and at the wingwalls. The rustication is recommended to be 3 feet 6 inches on center and be level along the face of the abutments and parallel to the bridge deck at the wingwalls.

2.3.6. Pier type and shapes

For multi-span structures, the pier type should consist of multiple columns that are evenly spaced. The pier cap will have the same shape and geometry as defined in Section 2.2.7, Pier Type and Shapes.

2.3.7. Bridge rail

The bridge rails will be Type 10M steel rail, with a duplex coating matching the colors identified in Section 6, Common Bridge Maintenance Items, on a concrete curb.

2.3.8. Bridge color treatments

The bridge coating limits and colors shall match those identified in Section 2.2.9, Bridge Color Treatments.

2.4. Atypical bridges

Atypical bridges are those structures that do not readily fall into the categories defined previously; bridges over I-25 and bridges carrying I-25. They are unique in their purpose, geometry or design. Such structures along the North I-25 corridor include those for pedestrians, railroads, flyover ramp bridges at the US 34/I-25 interchange, and the bridges associated with single-point urban interchange (SPUI) locations along the US 34 corridor. Structures that fall into this category are specifically listed in Table 2.1. Typically these structures will require a more detailed site-specific structure selection report to determine appropriate aesthetics, structure layout and type.

Table 2.1 North I-25 atypical bridges

Approximate I-25 mile post	Existing structure ID	Bridge description
245.825	D-17-DB	I-25 northbound (NB) over Great Western Railway (GWR)
245.826	D-17-DA	I-25 southbound (SB) over GWR
240.750	New	Pedestrian overpass
251.742	D-17-CE	I-25 NB over GWR
251.743	D-17-CB	I-25 SB over GWR
256.803	C-17-EJ	GWR over I-25
257.306	New	Ramp A – NB I-25 to westbound (WB) US 34
257.306	New	Ramp B – WB US 34 to SB I-25
257.306	New	Ramp C – SB I-25 to eastbound (EB) US 34
257.306	New	US34 over Rocky Mountain Avenue
257.306	New	US34 over Larimer County Road (LCR) 5
258.300	New	Pedestrian overpass
258.347	C-17-EP	I-25 NB over Union Pacific railroad (UPRR)
258.348	C-17-EO	I-25 SB over UPRR
266.435	B-17-BC	I-25 NB over GWR
266.436	B-17-BD	I-25 SB over GWR

2.4.1. Pedestrian bridges

Bridges that carry pedestrians over I-25 will be prominently viewed structures for motorists in both directions on I-25, and provide good pedestrian views to the west and east. These structures will span the ultimate I-25 cross section as defined in the North I-25 FEIS/ROD Preferred Alternative with no allowance for a pier in the I-25 median. Americans with Disabilities Act (AD) compliant ramps with stairs will be provided. Elevators will not be utilized to meet ADA requirements. The preferred structure type is similar in look and design to the tied arches along the I-25 corridor south of Denver with galvanized steel painted in accordance with the color palette defined for the North I-25 corridor. Where applicable, bridge elements will match the aesthetic criteria outline in Section 2.1, Structures over I-25. Pedestrian bridges at Park-and-Ride facilities will have enclosed walkways on both the bridge and on the approach ramps. Recreational pedestrian bridges will not have enclosed walkways, but will meet the fencing requirements outlined in Section 2.2 of the CDOT Bridge Design Manual. New pedestrian bridges over I-25 will meet the current code requirements for AASHTO LRFD Bridge Design Specifications 2012 and the LRFD Guide Specifications for Design of Pedestrian Bridges, 2nd Edition. The consideration of factors for Redundancy from Section 1.3.4 of the AASHTO LRFD Bridge Design Specifications 2012 will be included where applicable.

2.4.2. Railroad bridges

Bridges that carry I-25 over the railroad will have aesthetic considerations that match those outlined for structures carrying I-25 over state highways and county roads except as described herein. The bridge rail across the entire bridge is recommended to be a CDOT Type 10M with vinyl coated chain link fencing as shown in Appendix B. The chain link posts, rails, and accessories will be painted to match vinyl coating. Pier

types and shapes can be modified to accommodate pier protection walls for railroad collision as necessary. Colors for stains applied to structural elements shall match those identified in Section 6, Common Bridge Maintenance Items.

Bridges that carry the railroad over I-25 will have aesthetic considerations that match those outlined for structures that span I-25 in regard to substructure elements, exposed concrete finishes and concrete stain colors. Piers located in the I-25 median may be considered but shall be subject to CDOT approval. The superstructure is recommended to have a similar color palette, whether steel or concrete elements are used.

2.4.3. Ramp flyover bridges

It is the intent that aesthetic considerations for the ramp flyover bridges will follow those defined in Section 2.1, Structures over I-25, when possible to maintain a common corridor theme. Bridge rails are recommended to be a CDOT Standard Type 7 Bridge Rail.

Abutments slopes are defined in Section 2.1, Structures over I-25. MSE panel walls with precast concrete facing could be used for the construction of parallel ramp walls that lead up to the flyover bridges for economy of ramp construction or right-of-way constrictions. The use of such ramp walls would define a vertical wall face in front of the abutment system. If MSE panel walls are used at the flyover ramp abutments, the panels are recommended to match the requirements of Section 2.5.2, Wall Facings. Slopes in front of MSE panel walls are recommended to be no greater than 4:1. Final layout will be determined through the site-specific report.

Piers located in the I-25 median are allowed for economy of the ramp bridges and will follow the guidelines outlined in Section 2.1, Structures over I-25. The preferred pier is recommended to be a single oblong-shaped column sized in proportion to match piers described for bridges spanning I-25. The columns will have two vertical reveals on the wider face, and match the reveals defined in Section 2.1, Structures over I-25. The pier caps will be dependent upon the superstructure type.

2.4.4. SPUI bridges

The abutment slopes and other aesthetic considerations are defined in Section 2.2, I-25 over State Highways and County Roads; however, allowance is made for use of MSE panel walls with precast concrete facing to be used in the vertical abutment wall option. Final layout will be determined through the site-specific report.

For multi-span structures, the pier type and aesthetic considerations will follow the guidelines outlined in Section 2.1, Structures over I-25. The consideration of single or multiple circular columns is allowed. Pier caps are dependent on superstructure type.

2.5. Retaining walls

Where retaining walls are used in areas other than abutment slopes, the provision in Sections 2.5.1 through 2.5.3 shall apply.

2.5.1. Wall configurations

Retaining wall layout configurations will be controlled by the roadway geometry primarily. Fill configuration retaining walls will be aligned at the edge of the shoulder with an additional offset equal to the width of bridge rail supported on the retaining wall. Fill configuration retaining walls are shown in the figures in Section 3.4.1.1, Fill Configuration.

For retaining walls with bridge rail, a reinforced concrete rail anchor slab is required to resist lateral vehicle impact loads on the bridge rail. The minimum width of rail anchor slab is 8 feet wide. If possible, the rail anchor slab width will match the joint between lane and shoulder. If the shoulder width plus bridge rail curb is not adequate width for provide overturning resistance, provide a thicker rail anchor slab or a vertical overlap with the shoulder, rather than a rail anchor slab that extends into the lane.

Cut configuration retaining walls will be aligned either outside the edge of lower roadway in front of the cut wall or aligned at the edge of upper roadway. Cut configuration retaining walls are shown in the figures in Section 3.4.1.2, Cut Configuration.

The horizontal control line for retaining walls is at outside face of retaining wall. For fill configuration walls with bridge rail, the horizontal control line is at outside edge of bridge rail curb.

2.5.2. Wall facings

Retaining wall facings shall accommodate the corridor architectural treatments in a simple manner. Architectural treatments can be accommodated by a form-liner in precast concrete panels or cast-in-place concrete. Minimizing the number of unique architectural treatments will help achieve efficiency.

Architectural treatments should consider scale and texture as part of the approach to achieve an aesthetic concept. For example, long wall faces with variable height are better suited to moderate size architectural treatment, rather than large/tall treatments that do not fit on the shorter height portion.

Retaining wall facings shall have vertical joints that run from top of wall to bottom of wall. While the primary purpose of the vertical joints is to accommodate differential settlement along the wall, the vertical joints are a part of the architectural features.

Retaining wall facings shall be primarily 5 feet wide and 5 feet high, with permissible height increases up to 9.5 feet high for top and bottom panels.

Retaining wall facing panels on the other side of a vertical joint shall be offset vertically one-half panel height or 2.5 feet vertical offset.

2.5.3. Wall copings

Retaining wall copings shall be aligned to follow the top-of-wall vertical profile. The copings shall be 1.75 feet high and be cast-in-place reinforced concrete.

3. Base structure alternatives

For each structure location there are a number of structural alternatives that require evaluation. This section is intended to present alternatives for various common structure conditions, evaluate potential alternatives for those solutions, and provide the authors of site specific reports a recommended alternative or a reduced number of alternatives to evaluate

3.1. Structures over I-25

Existing structures that span over I-25 vary in width and have different features from structure to structure. The purpose of this section is to identify a structure type recommendation for the roadways that will be spanning over I-25. This section is not intended to propose phasing for the replacement of individual structures or cover all proposed features such as sidewalks, raised medians, or aesthetic features beyond those provided herein.

The roadway section used for the purpose of this report is shown in Figure 3.1 and is consistent with the proposed section for East Prospect Road over I-25. Several assumptions were necessary to evaluate the substructure of the alternatives to provide a baseline comparison:

- Bedrock is consistently 30 feet below grade.
- Bedrock has an allowable stress end bearing capacity of 40 kips per square foot (ksf) and allowable stress side shear capacity of 4 ksf.
- Bedrock has an end bearing capacity of 12 kips per square inch (ksi) for steel piles (50 ksi piling).
- For earthwork purposes, proposed grades of roads crossing over are 3 feet higher than existing grades.
- For earthwork purposes, locations of proposed abutments are similar to existing locations.
- All structure alternatives investigated use 20-foot-long approach slabs and strip seal expansion devices (0 to 4 inches) between the approach slabs and sleeper slabs.
- Proposed grade for all alternatives were assumed to be capable of meeting the minimum clearance requirements outlined in Section 5, Structures Design Criteria.
- Alternatives investigated did not identify specific construction phasing of any individual site and presumed that a flexible solution using temporary towers, strongbacks, or falsework can be identified and used.

Figure 3.1 East Prospect Road typical section

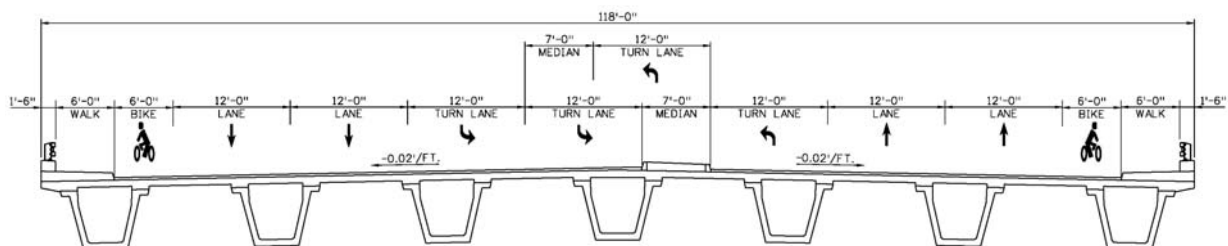

The evaluations of the bridge alternatives proposed herein were based on the following criteria:

- Meets all CDOT and American Association of State Highway and Transportation Officials (AASHTO) requirements
- Meets criteria of the structure aesthetics requirements contained in this report
- Construction cost
- Maintenance cost

Table 2.1 identifies bridges that are included in this section and shows the minimum structure length and width for each crossing as provided in the FEIS Preferred Alternative. These dimensions serve only as a starting point for determining structure length. The actual length and span arrangement will need to be determined in the site-specific type selection report.

Table 3.1 Bridges over I-25

Approximate I-25 mile post	Structure ID	Bridge description	EIS bridge length	Bridge width
245.217	D-17-DC	WCR 34 over I-25	216'-0"	71'-0"
247.215	C-17-AI	WCR 38 over I-25	216'-0"	71'-0"
252.261	C-17-BB	SH 60 (East) over I-25	216'-0"	119'-0"
254.217	NEW	LCR 16 over I-25	72'-0"/ 217'-9"/ 72'-0"	83'-0"
255.273	NEW	SH 402 over I-25	219'-6"	119'-0"
256.779	C-17-EK	LCR 20E over I-25	144'-0"/ 130'-0"	71'-0"
257.306	NEW	US34 over I-25	216'-3"	147'-0"
264.320	B-17-B	LCR 36 (Kechter Road) over I-25	216'-4"	71'-0"
268.475	B-16-AM	Prospect Road over I-25	216'-0"	119'-0"
269.37	NEW	SH 14 over I-25	202'-0"	155'-0"

3.1.1. Structure alternatives

Four different structure type options were investigated in this report to identify the preferred structure type for bridges over I-25. The four options investigated are:

- Option A: Spliced precast concrete tub girders
- Option B: Spliced precast concrete Bulb-T (BT) girders with fascia elements
- Option C: Steel box girder anchored end span
- Option D: Steel plate girder anchored end span with fascia elements

These four options were included in previous structure selection reports for bridges over North I-25. The options were modified from previous reports to modernize costs, to account for improved construction techniques, to use current available precast girder sections, and match preferred aesthetic options identified in this report.

3.1.1.1. Option A: Spliced precast concrete tub girders

In Section 2, Structure Aesthetics, three bridges (WCR 8, SH 52, SH 66) were identified by CDOT Region 4 staff as the preferred aesthetic for the bridges over I-25. Each of these bridges consisted of precast concrete tub girders spliced to create a continuous structure. These bridges were designed between the late 1990s and 2007.

The evolution of the use of tub girders is evident in these bridges as the girder shape changed for each bridge. Dimensions that varied between the three standard bridges are the girder width and depth. In this report, a 78-inch girder was evaluated due to the increase in efficiency. Roadway costs were not included in the evaluation of this report, but it should be noted that a shallower girder typically reduces roadway costs.

Of the four options investigated, this option proved to be the most cost effective for structure costs alone. The span configuration is a three span (65 feet 0 inch, 191 feet 4 inches, 65 feet 0 inch) and matches the desired span configuration defined in Section 2, Structure Aesthetics. This span configuration is economical as the secondary effects from post-tensioning redistribute some of the forces from the piers to the abutments. This reduces or eliminates the uplift forces and eliminates the need for counterweights or uplift resistance for piling.

The piers consist of single columns supporting each girder line and use features outlined in the aesthetics section of this report. Drop caps and full girder diaphragms between girders are not necessary as each girder is supported directly by columns and caisson foundations. Shallow diaphragms between girders can

easily be added and present only a minor increase in cost if necessary to mitigate impacts of extreme event load cases. If a diaphragm at the deck level is not sufficient for the 600 kip impact load a grade beam between caissons could be used. If grade beams are used, the top of grade beam should be a minimum of 1 foot 9 inch below proposed interim or ultimate grade.

Abutments consist of overhanging end diaphragm type abutments supported on piling. U style wingwalls and the tiered walls are easily incorporated into this structure as desired by the aesthetic in Section 2, Structure Aesthetics. Previous bridges constructed along the corridor used bearings between the abutment and the caissons; this was modified for this structure type to place the bearings at the girder seats to allow for inspection.

This structure type has flexibility in the location of girder splices and temporary support conditions. Precast tub girders are typically provided by one of two fabricators in the Denver area. Fully cast-in-place variations of this structure are not feasible due to need for falsework over the interstate.

3.1.1.2. Option B: Spliced precast concrete BT girders with fascia elements

A spliced precast concrete BT 72 superstructure is relatively similar in cost and shares several of the same features as the spliced tub girder alternative. The span configuration would be three span (65 feet 0 inch, 191 feet 4 inches, 65 feet 0 inch) and would match the desired configuration from Section 2, Structure Aesthetics. The abutments would consist of overhanging end diaphragm type abutments with U-shaped wingwalls and tiered wall fill slopes.

The piers cannot match those presented in Section 2, Structure Aesthetics, as 15 girders are necessary compared to the seven needed for tubs. A dropped cap with a full height diaphragm would be used with columns matching those outlined in Section 2, Structure Aesthetics.

This option would also require a fascia element to create the sloped shape of the exterior girder's desired aesthetic. Fascia elements would need to be adjustable to match chamber and deflection of the girders themselves and could consist of precast concrete or steel plates. Weight and connection concerns are problematic for precast fascia, and steel plate fascia is better suited to handle the necessary tolerances.

An alternative to using fascia elements is the use of precast tub girders as the exterior girders. Although this is feasible, the alternative is not without consequences. First, the tub girders are much stiffer than individual BT girders and would require a refined analysis during design. Second, the tub girders are much heavier than the BT girders and would require a larger crane for erecting the tub girders than what the BT girders would require alone. Third, there is reduced efficiency due to the different details necessary at closure pours, abutment diaphragms, and pier diaphragms. For these reasons, steel fascia panels were priced for this alternative.

The panels would be attached to the flanges and have a 7.75V to 1H slope. This slope is much steeper than the 4V to 1H slope on tub girders. Slopes flatter than 7.75:1 would require the fascia panels to be connected to both the deck and the girders.

With the inclusion of fascia panels, this option is slightly over the structural cost of Option A, but would be slightly less if the fascia panels were not included. The shallower girder depth would provide reduced roadway improvement costs.

Like Option A, spliced BT 72 girders allow for flexibility in construction and can be supported temporarily with strongbacks, towers, or falsework. Three suppliers are present in the Denver area for this girder type.

3.1.1.3. Option C: Steel box girder anchored end span

Of the options considered, this option has the largest construction cost. The bridge would be a three-span bridge with the main span of 191 feet 4 inches but would have shortened end spans (36 feet 8 inch) that would allow for a thinner superstructure. Shorter spans than those identified in Section 2, Structure Aesthetics were used as the longer spans (65 feet 0 inch versus 36 feet 8 inch) did not eliminate the need for uplift resistance at the abutments and caused a larger girder section at the piers. The steel tub girders would vary in depth from 5.25 feet to 7.25 feet and, due to the varying depth, the webs would be vertical to be more economical. The thinner superstructure would provide a savings for roadway embankment but also causes additional structure cost to create counterweights at the abutments.

The abutments for this structure would be large to resist uplift forces and would have deep piling foundations. The short end spans would require taller tiered walls than those at the precast concrete alternatives. Often the end spans of structures of this type are hidden by walls to make the piers appear to

be abutments and the superstructure appear to be a more elegant single span. Anchored end spans over I-70 at Genesee and on Vail Pass use this technique. For the purpose of this report, the hide walls were used and assisted in the uplift resistance at the abutments.

Piers would be a wall type to create the appearance of an abutment and would be supported on drilled caissons. If hide walls were not used, the pier types and columns recommended in the aesthetic portions of this report could be used. A single column under each steel box girder would be used.

Using the hidden end span would create lower costs for the tiered abutment slope walls and the thinner superstructure would provide measurable savings, but the savings would not be likely to offset the significant additional structural cost over the precast concrete alternatives.

The use of steel girders allows for improved dead load deflection and camber control and splice locations can be modified to accommodate a phased erection over I-25.

The use of weathering steel allows for simpler maintenance than that of painted steel bridges but has been recognized to corrode due to anti-icing agents. Regular inspections of steel bridges require greater effort than concrete bridges.

3.1.1.4. Option D: Steel plate girder anchored end span with fascia elements

This alternative is similar to the steel box girder anchored end span described for Option C with an identical span configuration, similar abutments, and similar piers, but would use plate I girders in lieu of steel boxes. The exterior girder could be replaced with a steel box or use a fascia element. Because the depth varies, the fascia elements would be costly and would be simpler to incorporate as part of the design section. The cost of this alternative was derived using exterior box girders and interior plate girders. The different stiffness of the exterior girders versus the interior girders would require additional analysis.

The substructure would be identical to the steel box option unless hide walls were not used. If hide walls were not used the piers would require a dropped cap to handle the additional girders present (13 girders versus seven steel boxes). The cost of this option was slightly less than the steel box option.

3.1.2. Recommended option

The recommended structure type for new bridges over I-25 are three-span (65 feet 0 inch, 191 feet 0 inch, 65 feet 0 inch) spliced precast concrete tub girders. Figure 3.2 rates of the four options for the evaluation criteria presented earlier in this report.

Figure 3.2 Bridges over I-25 option evaluation

	Option A: Spliced Precast Concrete Tub Girders	Option B: Spliced Precast Concrete BT 72	Option C: Steel Box Girder Anchored End Span	Option D: Steel Plate Girder Anchored End Span
Meets CDOT and AASHTO Requirements	●	●	●	●
Meets Aesthetic Requirements	●	●	●	○
Construction Cost	●	●	○	○
Maintenance Cost	●	●	●	●

Good = ○ Better = ● Best = ●

The precast concrete tub girder option matches the preferred CDOT aesthetics, is the lowest cost option, can incorporate construction phasing to meet site-specific requirements, and is simple to maintain.

Site-specific reports for structures over I-25 should incorporate refined girder dimensions and layouts for site-specific constraints, address construction phasing, set fill slopes and associated wall layouts, update cost estimates using the precast concrete tub girder recommended structure type, and determine appropriate pier and abutment foundation types.

This page intentionally left blank.

This page intentionally left blank.

3.2. Structure alternatives: I-25 over state highways, county roads, and drainage features

The North I-25 EIS identified a variety of locations where I-25 will bridge over various features. This section is intended to categorize these features into similar groups, provide guidance on span configurations, and provide authors of site-specific structure selection reports a reduced number of structure alternatives to explore.

3.2.1. Layout and type

The roadway configurations for the facilities that I-25 crosses can be separated into four categories: rural roads, urban roads, interchanges, and drainage features. These categories are provided as a baseline for the North I-25 corridor projects. The widths of the roadway facilities that are crossed are obtained from the North I-25 FEIS/ROD. The intent of the length of the crossings is to provide for any improvements anticipated within the next 30 years. Although these plans are not all known at this time, it is assumed that a minimum standard will be set by road type. Roads that currently have information available regarding any future improvements will be incorporated into the appropriate site-specific structure selection memorandum.

3.2.1.1. Typical section

The width of I-25 as identified in the Preferred Alternative section of the North I-25 FEIS/ROD document is shown in Figure 3.3.

Figure 3.3 Typical I-25 cross section – SH 14 to SH 66

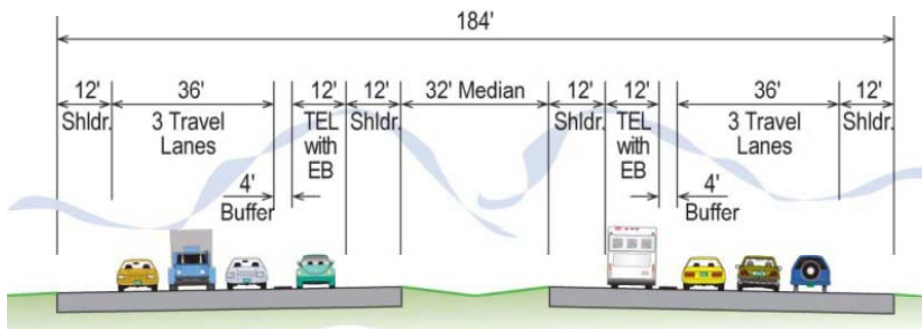

For structures carrying I-25, the CDOT Type 10M railing is commonly used. The prescribed roadway configuration in Figure 3.3 and bridge railing define the out-to-out width of the bridges to be 79 feet.

3.2.2. Span length

The tables in the following subsections show the minimum structure length and width for each crossing as provided in the FEIS Preferred Alternative and are provided for reference only. The final length and width of these structures will be determined in the site-specific reports.

3.2.2.1. Rural roads

Rural roads are those considered by local jurisdictions to be rural in nature and present only limited increases in traffic volumes. Table 3.2 is a list of the locations identified by the EIS where I-25 crosses over a rural road.

Table 3.2 I-25 bridges over rural roads

Approximate I-25 mile post	Structure ID	Bridge description	EIS bridge length	Bridge width
249.316	C-17-AT	I-25 NB over Valley Road	110'-0"	79'-0"
249.317	C-17-AS	I-25 SB over Valley Road	110'-0"	79'-0"
253.187	C-17-BQ	I-25 NB over LCR 14 (SH 60 West)	100'-0"	79'-0"
253.188	C-17-BR	I-25 SB over LCR 14 (SH 60 West)	100'-0"	79'-0"

The span configurations in Table 3.2 were determined assuming the following:

- Roadway width = 44 feet
- Vertical clearance = 16 feet 6 inches
- Slopes = tiered walls representing a 2:1 slope
- Integral abutments
- Abutment thickness = 4 feet

Recently constructed structures along North I-25 crossing similar facilities have incorporated single MSE retaining walls in front of the abutments. Two examples of this type of crossing are I-25 over WCR 20 and I-25 over WCR 28; these structures serve as the template for proposed structures over rural roads. The minimum bridge length recommended for these structures is 121 feet 0 inch (measured from back face of abutments). This length can accommodate the current rural roadway section and planned or potential increased roadway sections in the future. The assumed rural section for these crossings is shown in Figure 3.4.

Figure 3.4 Rural road typical sections

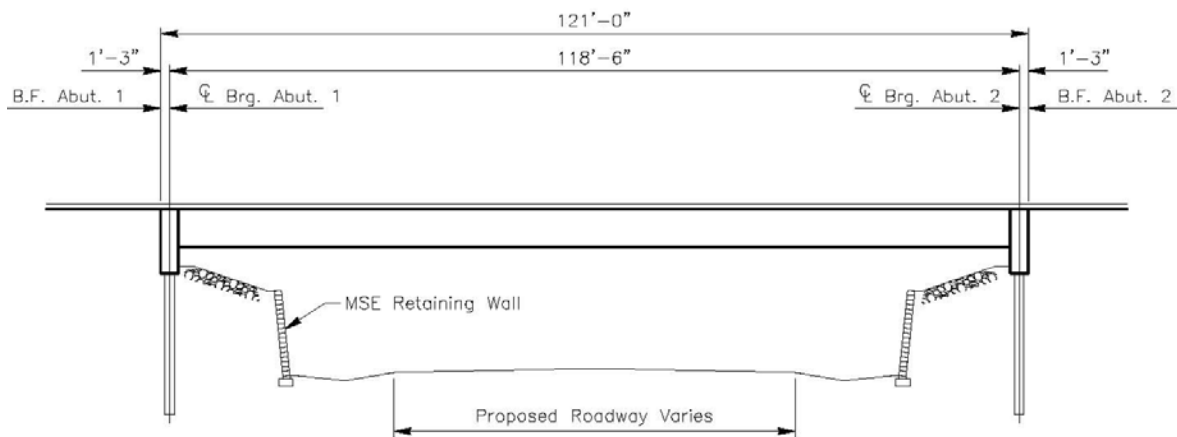

3.2.2.2. Urban roads

Urban roads are those considered to have an urban roadway section per the local jurisdiction design criteria. These crossings are expected to have larger future growth than the rural roads. Table 3.3 is a list of the locations identified by the EIS where I-25 crosses over an urban road.

Table 3.3 I-25 bridges over urban roads

Approximate I-25 mile post	Structure ID	Bridge description	EIS bridge length	Bridge width
244.195	D-17-CZ	I-25 NB over WCR 32	131'-3"	79'-0"
244.196	D-17-CY	I-25 SB over WCR 32	131'-3"	79'-0"
251.236	C-17-DY	I-25 NB over WCR 46	131'-3"	79'-0"
251.237	C-17-DH	I-25 SB over WCR 46	131'-3"	79'-0"

The span configurations in Table 3.3 were determined assuming the following:

- Roadway width = 68 feet
- Vertical clearance = 16 feet 6 inches
- Slopes = tiered walls representing a 2:1 slope
- Integral abutments
- Abutment thickness = 2.5 feet

The minimum bridge length recommended for these structures is 152 feet 0 inch (measured from back face of abutments). Tiered walls are incorporated to maintain a consistent corridor aesthetic. The walls can be located to accommodate planned ultimate roadway sections. The recommended span configuration for an urban crossing is shown in Figure 3.5 and Figure 3.6 for both a single span option and a two-span option.

Figure 3.5 Recommended urban road typical section for single-span configuration

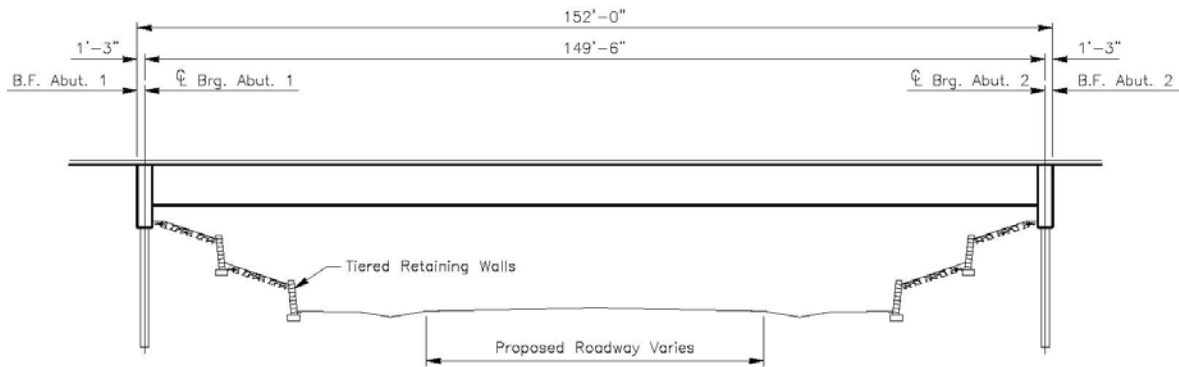
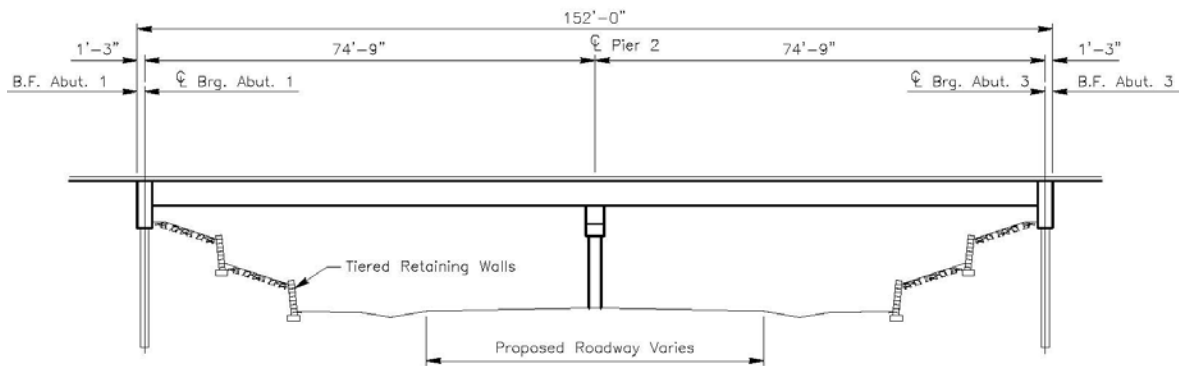

Figure 3.6 Recommended urban road typical section for two-span configuration



3.2.2.3. Interchanges

Span arrangements for interchange structures will be dependent upon the site geometry, proposed and future roadway sections, and allowable vertical clearance. The structures should aim to reduce the structure depth as much as possible to reduce the amount of approach work that will be needed. Using a two-span or three-span configuration will reduce the new structure's depth and approach work. As an example, the three-span arrangement shown below can reduce the structure depth by 2 feet when compared to the 148-foot single span structure in the EIS table. Table 3.4 is a list of the locations identified by the EIS where I-25 crosses over an interchange location. Additionally, the structures should provide a balanced span arrangement that incorporates corridor aesthetic.

Table 3.4 I-25 bridges over interchange locations

Approximate I-25 mile post	Structure ID	Bridge description	EIS bridge length	Bridge width
250.241	NEW	I-25 NB over SH 56	148'-0"	79'-0"
250.241	NEW	I-25 SB over SH 56	148'-0"	79'-0"
259.309	C-17-ES	I-25 NB over Crossroads Blvd. (LCR 26)	148'-0"	79'-0"
259.310	C-17-ET	I-25 SB over Crossroads Blvd. (LCR 26)	148'-0"	79'-0"

The span configurations in Table 3.4 were determined assuming the following:

- Standard diamond interchange
- Roadway width = 116 feet
- Two 12-foot future lanes with additional 2-foot shoulders
- Vertical clearance = 16 feet 6 inches
- Vertical abutments
- Abutment thickness = 4 feet

Example span configurations are shown in Figure 3.7 and Figure 3.8.

Figure 3.7 Recommended interchange typical section for two-span configuration

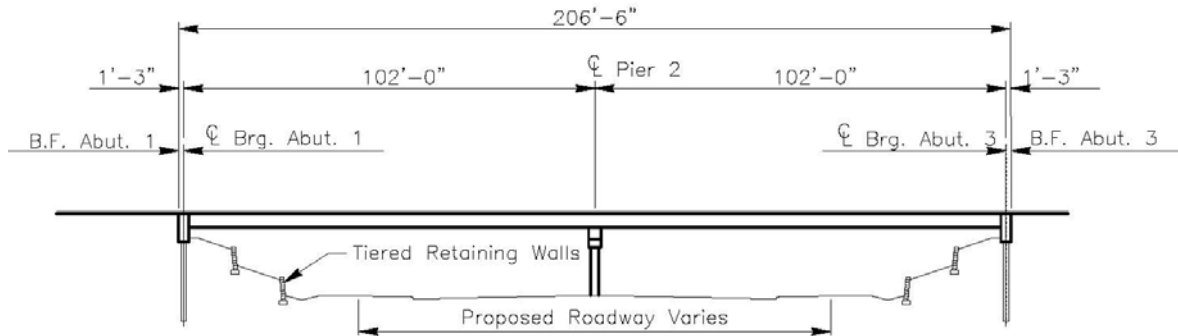
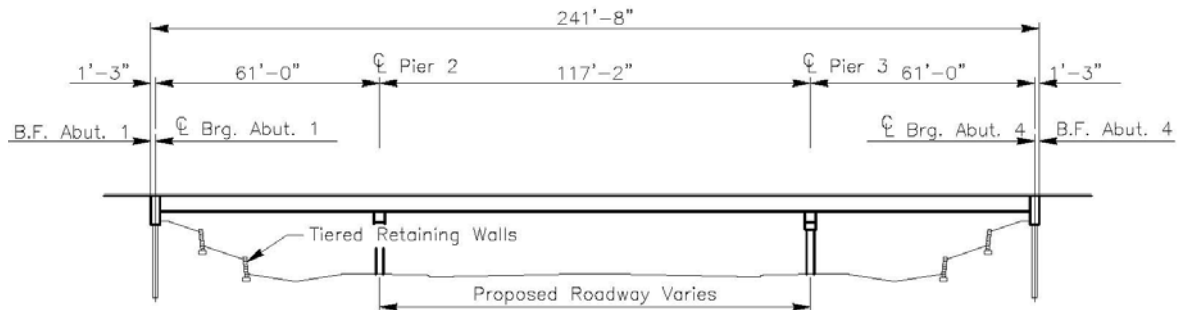

Figure 3.8 Recommended interchange typical section for three-span configuration



3.2.2.4. Drainage features

The EIS identified several locations where I-25 crosses over various drainage features. These features vary from rivers to canals and ditches. Each structure's span configuration and superstructure type alternatives will be dependent on the site geography and hydraulic requirements. The site-specific structure selection reports will address recommendations and evaluate alternatives individually. Table 3.5 is a list of the locations identified by the EIS where I-25 crosses over a drainage feature.

Table 3.5 I-25 bridges over drainage features

Approximate I-25 mile post	Structure ID	Bridge description
245.437	D-17-DD	I-25 over North Creek
246.960	NEW	I-25 over Drainage
249.400	NEW	I-25 over Draw
249.841	C-17-N	I-25 SB over Little Thompson River
249.842	C-17-A	I-25 NB over Little Thompson River
252.670	NEW	I-25 over Draw
252.670	NEW	I-25 over Draw
254.826	NEW	I-25 over Draw (Hillsboro Ditch)
254.827	NEW	I-25 over Draw (Hillsboro Ditch)
254.89	C-17-G	E Frontage Road over Draw (Hillsboro Ditch)
256.603	C-17-BM	I-25 NB over Big Thompson River
256.604	C-17-BL	I-25 SB over Big Thompson River
256.67	C-16-F	I-25 Service Road over Big Thompson River
257.852	C-17-CI	Greeley-Loveland Ditch
264.319	NEW	I-25 over Cache la Poudre Floodway
264.319	NEW	I-25 SB on Ramp over Cache la Poudre Floodway
264.321	NEW	LCR 36 over Cache la Poudre Floodway
264.322	NEW	LCR 36 (Kechter Road) over Cache la Poudre Floodway
264.323	NEW	I-25 over Cache la Poudre Floodway
265.316	NEW	Harmony Rd over Cache la Poudre Floodway
265.846	B-17-DI	I-25 NB over Cache la Poudre River
265.847	B-17-BB	I-25 SB over Cache la Poudre River
268.632	B-16-BK	Lake Canal
268.641	B-16-BF	Timnath Ditch (Cache la Poudre Reservoir Inlet)
268.813	B-16-EY	Box Elder Creek

3.2.3. Superstructure types considered

The possible structure types for either replaced or modified bridges are quite similar throughout the corridor. To avoid repetition, the potential structural types are summarized here in general terms. Site-specific issues are addressed in the selection reports dedicated to each bridge.

The following structure types may be considered for structures carrying I-25 over roadways and drainage features:

- Prestressed concrete girders
- Steel girders
- Other alternatives

3.2.3.1. Prestressed concrete girders

Prestressed concrete girders are fabricated offsite and shipped to the job site for installation, where they are usually erected by crane. A variety of girder shapes and sizes can be fabricated, with the most common being BTs, solid slabs, hollow boxes, and U-shaped tubs. Slabs and boxes can be placed side-by-side allowing for a thinner composite topping thereby minimizing the amount of roadway approach work and eliminating the need for deck formwork (except at the overhangs). Use of the prestressed concrete slabs can accelerate the construction schedule while also reducing construction cost. Prestressed concrete superstructures are the most common type of system built in Colorado. There are three precast girder fabricators in Colorado and most contractors are familiar with this structure type.

The following are advantages to using prestressed concrete girders:

- Economical structure type
- Simple and quick construction
- Minimal construction activity within railroad rights-of-way
- Minimal construction activity within watercourses
- Minimal falsework and disruption to traffic
- U-shaped tubs are aesthetically pleasing
- High quality control/quality assurance of girders

The following are disadvantages to using prestressed concrete girders:

- Less efficient for spans over 150 feet
- U-shaped tubs and deep boxes are heavy members requiring larger hauling and erection equipment.

3.2.3.2. Steel girders

A variety of girder shapes and sizes can be fabricated, with the most common being rolled I-sections, welded plate I-sections, and welded box girders. Steel structures would need to be shipped from out-of state because there are no steel bridge fabricators in Colorado. There are also fewer contractors that have experience with steel superstructure systems in Colorado as steel bridges are a less common structure type.

The following are advantages to using steel girders:

- Efficient for longer spans
- Shallower superstructure depths for a given span
- High quality control/quality assurance of girders
- Lighter superstructure, which can reduce size and costs of required substructure units
- Minimal construction activity within railroad rights-of-way
- Longer spans can reduce construction activity with watercourses
- Easily handle curved alignments
- Aesthetically pleasing structures, particularly the box-shaped entities

The following are disadvantages to using steel girders:

- Limited span lengths with rolled shapes
- Steel prices and availability are more volatile than concrete
- Painting and maintenance required over life of structure
- Maintenance needs over railroad rights-of-way
- Maintenance needs over watercourses

3.2.3.3. Other Structure Alternatives

Other alternative structure types may be considered for each bridge crossing provided they meet applicable CDOT bridge criteria. Structure types that have been used for similar roadway crossings in Colorado include cast-in-place concrete box girders, spliced prestressed concrete girders, and concrete box culverts. The cast-in-place structures are built in place and can accommodate virtually any geometric configuration and are efficient for longer span structures. The spliced girder structures can also achieve greater span lengths and can take advantage of the precast components to decrease the construction duration. For the majority of bridges carrying I-25, longer span structures are not anticipated; therefore, these structure types are not preferred. Drainage features may have short enough spans in which box culverts can be used.

3.2.3.4. Superstructure selection matrix

The matrix in Figure 3.9 provides a preliminary reference for narrowing the structure selection.

Figure 3.9 Superstructure selection matrix

	Structure type	Span efficiency	Span to depth ratio	Aesthetics	Construction cost	Construction impacts	Long-term maintenance
Prestressed Concrete Structures	Side-by-Side PC\PS Slabs	<48'	●	●	●	●	●
	Side-by-Side PC\PS Box Girders	65' to 130'	●	●	●	●	●
	Spaced PC\PS Box Girders	45' to 115'	●	●	●	●	●
	PC\PS BT Girders	90' to 150'	○	○	●	●	●
Steel Structures	Steel Plate I-Girders	60' to 300'	●	○	●	●	○
	Steel Box Girders	90' to 300'	○	●	○	●	○
Other Structure Alternatives	Cast-in-Place PT Box Girders	100' to 250'	○	○	●	○	●
	Spliced PC\PS BT Girders	114' to 240'	○	○	●	●	●
	Sliced PC\PS U-Girders	130' to 215'	○	●	●	●	●
	Box Culverts	<20'	●	○	●	○	●

Good = ○ Better = ● Best = ●

The results of this figure show that prestressed concrete girders are the best suited structure type. Each site along the corridor will have different controlling factors. For the most beneficial use of this table, the results can be broken into two categories, maximizing structure efficiency and minimizing roadway impacts.

3.2.3.4.1. Structure Efficiency

Structures at sites not precluded by the site geometry, hydraulics, or minimum vertical clearance, etc., should use of PC/PS BT girders. This structure type provides longer, more efficient spans at reasonable costs.

3.2.3.4.2. Roadway Impacts

For structures that are constrained by the site geometry, a lower profile structure such as PC/PS box girders or slabs are recommended to reduce the impacts to the roadway approaches and feature being crossed. The use of multi-span structures can reduce the structure depth further, however the cost of the additional substructures needs to be considered.

3.2.4. Substructure types considered

Given the similarities in substructure types for each bridge, potential systems for the project are discussed globally in this section. Bridge-specific issues are addressed in the site-specific reports dedicated to each bridge.

3.2.4.1. Foundations

Foundation selection for abutments and piers will be addressed in the site-specific report for each structure.

3.2.4.2. Abutments

When the overall length of the bridge structure is short enough to allow them, integral abutments are the preferred substructure solution for typical CDOT bridges. They are relatively easy to construct, have a proven performance history, and generally require little maintenance over their service life. Abutments are recommended to be designed as U-shaped abutments on spread footings or pile foundations. The front faces of the abutments are intended to be constructed parallel to the roadway being spanned at all grade separations. The wingwalls are recommended to be constructed parallel to the roadway being carried above.

An integral or semi-integral abutment does not use conventional bearings or deck joints at the abutment, which eliminates future maintenance issues associated with the replacement or repair of expansion joints and bearings at the abutments. The thermal movement of the bridge is accommodated through flexure of a single row of piling.

Abutments at drainage features are recommended to be protected with rip rap upstream, downstream, as well as underneath bridge structures and should be designed per the scour recommendations provided in the hydraulic analysis.

3.2.4.3. Piers

Conventional substructures with a multi-column pier and cap are commonly used in this region and have been found to be efficient and economical. This system can accommodate variable width structures, skewed geometry, and can be used to transfer lateral loads to the foundations. Hammerhead and single pier columns would not be practical for these bridge structures. Multi-column piers and caps are recommended for the North I-25 structures over state highways, county roads, and drainage features.

Piers located in or adjacent to waterways and drainage features are recommended to be protected with rip rap and should be designed per the scour recommendations provided in the hydraulic analysis.

3.3. Structure layout and type: atypical bridges

Atypical bridges are those structures that do not readily fall into the two categories defined previously: bridges over I-25 and bridges carrying I-25. They are unique in their purpose, geometry, or design. Such structures along the North I-25 corridor include those for pedestrians, railroads, flyover ramp bridges at the US 34/I-25 interchange, and the bridges associated with SPUI locations along the US 34 corridor. Structures that fall into this category are specifically listed in Table 2.1. Typically these structures will require a more detailed site-specific structure selection report to determine appropriate aesthetics, structure layout, and type.

Only those structure types commonly designed by CDOT will be considered. New and innovative structure types require CDOT approval prior to investigation and use.

3.3.1. Pedestrian bridges

Bridges that carry pedestrians over I-25 will be prominent structural features on the North I-25 corridor. The following design parameters apply:

- No allowance for a pier in the I-25 median
- Minimum of 12 feet 0 inch clear width
- Minimum of 17 feet 6 inches vertical clearance to I-25
- ADA accessible ramps with stairs (no elevators)
- Non-slip deck surface treatment
- Safety fence or barriers to prevent projectiles from the bridge (minimum 8 feet 0 inch)
- Adequate pedestrian or bicycle-scaled lighting to create safe environments

3.3.2. Railroad bridges

The typical section, viable superstructure types, and substructure element options for bridges carrying I-25 over the railroad are defined in Section 2.2, I-25 over State Highways and County Roads. Meetings with all affected railroad entities will be conducted to discuss current and future rail and maintenance road needs. Span configuration will be determined through the site-specific structure selection report based on input from these meetings.

The typical section for bridges that carry the railroad over I-25 will be defined through meetings with the GWR and documented in the site-specific structure selection report along with span configuration and viable superstructure types.

In addition to design criteria defined in Section 5, Structures Design Criteria, all bridge elements will conform to the *BNSF Railway – Union Pacific Railroad Guidelines for Railroad Grade Separation Projects*, the *OmniTRAX Technical Specifications for Industrial Tracks*, and the *American Railway Engineering and Maintenance-of-Way Association (AREMA) Manual for Railway Engineering*.

3.3.3. Ramp flyover and SPUI bridges:

Span configuration and associated superstructure types considered are dependent on final geometric layout and will be discussed in site-specific structure selection reports for these bridges.

Substructures can be founded on piles, caissons, or spread footings. Foundations will be determined in the site-specific reports.

Piers are allowed in the I-25 median for the ramp flyover structures for consideration of span layout and shall be designed in accordance with current AASHTO provisions for collision loading.

3.4. Retaining walls

The potential use of retaining walls occurs at various locations along the North I-25 corridor. This section is intended to identify the design criteria, categorize retaining walls into similar groups, and provide guidance to the authors of site specific structure selection reports a reduced number of structure alternatives to explore.

3.4.1. Configurations

Retaining wall configurations include “fill configuration” retaining walls and “cut configuration” retaining walls.

3.4.1.1. Fill configuration

Retaining walls in fill configuration are a configuration where the retaining walls support an embankment higher than the surrounding ground. Fill configuration retaining walls could support a roadway embankment above a lower existing ground or a lower proposed ground surface. Fill configuration retaining walls could support a roadway approach to a bridge over another feature. Figure 3.10 and Figure 3.11 show fill configuration retaining wall typical sections.

Figure 3.10 Fill configuration retaining wall typical section, supporting roadway

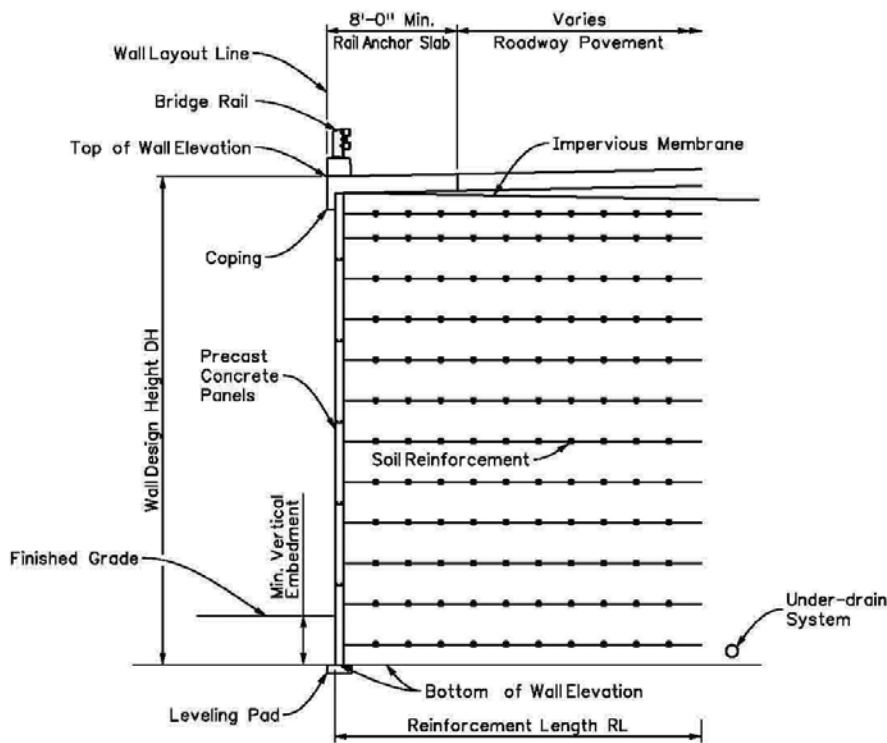
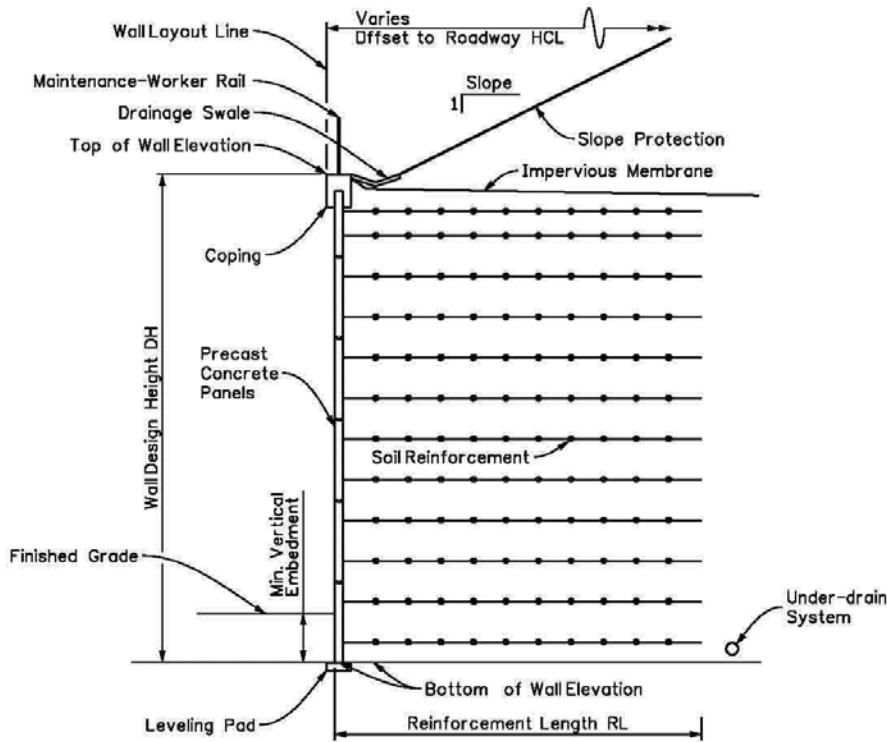

Figure 3.11 Fill configuration retaining wall typical section, not at roadway edge



3.4.1.2. Cut configuration

Retaining walls in cut configuration are a configuration where the retaining walls support an existing surface to accommodate a lower surface in front of the retaining walls, such as a proposed roadway in front of an existing surface. Cut configuration retaining walls could be located near the base of the slope or at the top of slope. Cut configuration retaining walls could be used to support an existing abutment embankment to accommodate a widened roadway under the bridge. Figure 3.12 and Figure 3.13 show cut configuration retaining wall typical sections.

Figure 3.12 Cut configuration retaining wall typical section at base of slope

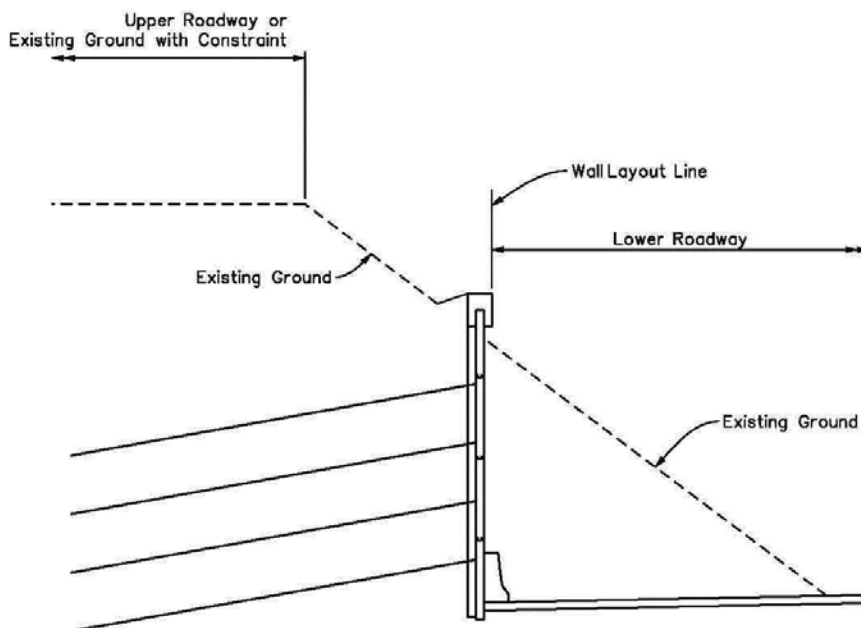
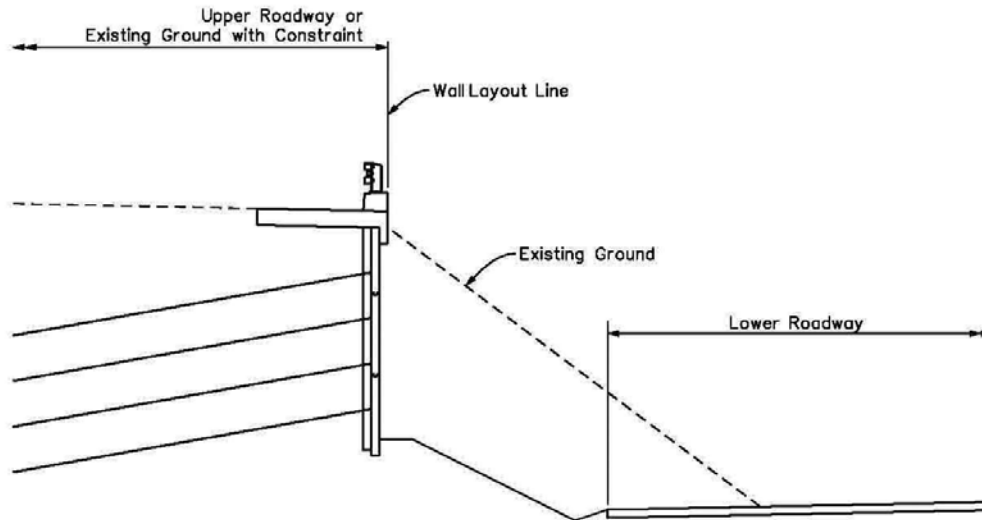

Figure 3.13 Cut configuration retaining wall typical section at top of slope

3.4.2. Retaining wall design requirements

Retaining wall design shall conform to the procedures in the *AASHTO LRFD Bridge Design Specifications* (LRFD). The LRFD addresses retaining wall foundations in the context of external stability provisions.

3.4.2.1. Strength I Limit State

For design of retaining wall foundations, the Strength I Limit State is required for factored bearing resistance comparison to factored bearing pressure, for calculation of the location of resultant force as an evaluation of the retaining wall foundation width, and for factored sliding resistance comparison to factored applied force resistance.

3.4.2.2. Extreme Event I Limit State

Seismic performance is considered in the design of retaining wall in the Extreme Event I Limit State. Using parameters from the geotechnical report, the peak ground acceleration, spectral acceleration, site coefficient, damped horizontal response spectral acceleration coefficient at one-second period modified by long-term site factor (SD_1), soil profile, and seismic zone are determined. For $SD_1 < 0.15$, Seismic Zone 1 applies. From experience with LRFD design of retaining walls, Extreme Event I Limit State does not control the retaining wall design of retaining walls in Seismic Zone 1, which applies in most of Colorado. Extreme Event I Limit State should only be considered for retaining walls in Seismic Zone 2, or for sites with foundations subject to liquefaction.

3.4.2.3. Extreme Event II Limit State

For retaining walls containing a bridge rail and retaining an adjacent roadway, vehicle loads applied to bridge rails are applied in the Extreme Event II Limit State using AASHTO LRFD Section 13 and Appendix 13A. Retaining walls supporting a roadway with bridge rail require a rail anchoring slab to resist the loads on the bridge rail. From experience with LRFD design of retaining walls, Extreme Event II Limit State does not control the design of moderate or tall retaining walls, but potentially controls the design of short-height retaining walls.

3.4.2.4. Service I Limit State

The Service I Limit State is required for evaluation of performance, including settlement and lateral deformations. For design of retaining wall foundations, the Service I Limit State bearing resistance is correlated to an acceptable total settlement, such as a limit of 2 inches total settlement.

The Service I Limit State bearing resistance shall not exceed the values in the geotechnical report. Retaining wall height is the main parameter affecting the applied service bearing pressure. The main affect of applied service bearing pressure is the retaining wall height. Footing width, or reinforcement length of MSE walls, affect applied service bearing pressures between 1.3 and 1.0 times the vertical embankment load pressure.

Retaining wall heights that generate applied service bearing pressures that do not exceed service bearing resistance and that have been correlated to acceptable settlement/deformation, will perform within an acceptable range.

Retaining wall heights that generate applied service bearing pressures that exceed service bearing resistance that has been correlated to acceptable settlement/deformation, will not perform within an acceptable range of settlement or deformation without a design solution. Solution alternatives include deep foundations, foundation improvements, monitored time-consolidation, load reduction such as structural-grade polystyrene, or other alternatives.

The Service I Limit State is also required for evaluation of overall stability, sometimes called global stability. The overall stability of the retaining wall, retained slope, and foundation soil should be evaluated using limiting equilibrium methods of analysis. Sites with soft foundation soils, or sites with tiered walls, sometimes have overall stability analysis as the controlling design condition.

The “Service Limit State” uses different load factors and resistance factors, compared to the “Strength Limit State”. For evaluation of settlement and/or deformations, live loads and live load surcharge are omitted, since only permanent loads contribute to the settlement and/or deformation configurations.

3.4.2.5. LRFD foundation design

The LRFD provisions for using the Strength I Limit State and Service I Limit State are applicable to retaining wall foundation design in the context of external stability.

Development of appropriate geotechnical parameters is key to conducting the Strength I Limit State and Service I Limit State evaluation, and to performance that is correlated to the anticipated performance. Nominal bearing resistance (formerly described as ultimate bearing resistance) multiplied by a corresponding resistance factor, yields the factored bearing resistance for comparison to Strength I Limit State factored loads. Reinforced concrete cantilever retaining walls typically have a lower nominal bearing resistance than MSE retaining walls, since reinforced concrete cantilever retaining walls are more rigid than MSE retaining walls.

Service I Limit State bearing resistance (formerly described as allowable bearing capacity) is correlated to an acceptable settlement limit and corresponding performance characteristics, and then compared to Service I Limit State applied bearing pressure. Reinforced concrete cantilever retaining walls and MSE retaining walls have similar “Service Limit State” bearing resistance since their settlement and deformation performance is similar, and have similar Service I Limit State applied bearing pressures since their foundation widths are similar for comparable height.

After appropriate geotechnical parameters are developed for the Strength I Limit State and the Service I Limit State, the evaluation shall compare the Strength I Limit State resistance to applied loads (bearing, location of resultant, sliding), and compare the Service I Limit State bearing resistance to the applied service bearing pressure without live load. For retaining wall heights above the threshold height where bearing resistances equal to service applied bearing pressure loads, the retaining walls require a foundation solution. Foundation solutions include deep foundations, foundation improvements, monitored time-consolidation, or other alternatives.

Overall stability, sometimes called global stability, should be evaluated in the Service I Limit State. The overall stability of the retaining wall, retained slope, and foundation soil should be evaluated using limiting equilibrium methods of analysis. Sites with soft foundation soils, or sites with tiered walls, sometimes have overall stability analysis as the controlling design condition.

3.4.3. Structure type alternatives

Retaining wall design shall conform to the procedures in the LRFD. The LRFD address retaining wall foundations in the context of external stability provisions.

3.4.3.1. Fill walls with adequate service bearing resistance

Retaining walls where the service bearing resistance is adequate for the applied service bearing pressure will perform within an acceptable range of settlement and deformation. The service bearing resistance is correlated to acceptable settlement and deformation parameters, and retaining walls with applied service bearing pressures that do not exceed the service bearing resistance will perform adequately.

Retaining wall height is the main parameter that affects applied service bearing pressure. Foundation width or retaining wall type affect applied service bearing pressure between 1.3 and 1.0 times the vertical embankment load pressure.

The Service I Limit State will predominately control retaining wall foundations. The Strength I Limit State rarely controls retaining wall design.

Feasible structure types were considered and evaluated as a solution for retaining wall fill configurations that have with adequate service bearing resistance. Feasible structure type alternatives were evaluated to conform to and to accommodate the structure configuration according to the evaluation criteria. The structure type evaluation is for retaining wall alternatives that provide adequate foundation strength, provide adequate service resistance correlated to acceptable settlement and deformations, do not require deep foundations or other foundation solutions, and provide service performance within the settlement and deformation criteria.

3.4.3.1.1. MSE wall with precast concrete face

MSE retaining walls consist of granular soil reinforced by layers of soil reinforcement. The soil reinforcement resists lateral earth loads through friction against the granular soil. Soil reinforcement material properties conform to performance specifications. Internal stability is provided by soil reinforcement of sufficient length and strength for a chosen spacing within the parameters of the performance specifications. The reinforced soil functions as a gravity retaining wall system. External stability evaluations are conducted for the Strength I Limit State, Extreme Event I Limit State, and Extreme Event II Limit State evaluations, including checks of bearing resistance, location of the resultant force, and sliding resistance. Performance for settlement and/or deformations are evaluated for the Service I Limit State, including service applied bearing pressure, compared to the service bearing resistance that was correlated to acceptable settlement criteria. Retaining wall heights that result in service applied bearing pressures within the service bearing resistance that was correlated to settlement criteria, do not require deep foundation solutions.

The facing provides weather resistance and resists lateral soil loads between soil reinforcement layers. Vertical joints between facing panels should be aligned so that the vertical joints run from top to bottom of wall, to best accommodate differential settlements and deformations along the wall. A coping accommodates a sloping top of wall profile. A bridge rail is accommodated on top of the wall by incorporation of a reinforced concrete rail anchoring slab.

Construction time is relatively short; construction details and assembly are fairly simple; and multiple MSE suppliers are available.

During final design, plans and specifications are developed to give MSE suppliers the parameters and requirements for soil reinforcement. Prior to implementation of LRFD design, CDOT MSE wall worksheets and non-LRFD special provisions were used to define those parameters and requirements for soil reinforcement. For LRFD design, MSE wall details corresponding to LRFD, and special provisions corresponding to LRFD, are used.

The following are advantages to MSE walls with precast concrete face:

- Least cost solution for wall design heights above 8 feet design height.
- Accommodate various horizontal and vertical alignments, except tight curves.
- Experienced contractors and available suppliers.
- Shallow foundations, no foundation improvement needed.

The following are disadvantages to MSE walls with precast concrete face:

- Geometric constraints for horizontal vertical alignments with tight curves are not accommodated as well with MSE walls.
- All retaining walls experience some settlement and lateral deformation, which must be compared to the project tolerances for settlement and lateral deformation.
- Differential settlement should be controlled to limit damage to face.
- Foundation improvement needed if strength factored bearing pressures exceed factored bearing resistance of in-place foundation material, or if service applied bearing pressures exceed bearing resistance that was correlated to settlement performance, often occurring on tall walls.

3.4.3.1.2. MSE wall with full-height precast concrete face

MSE retaining walls may be constructed with full height panels in lieu of more discrete panels. In these walls, the panels rarely serve a structural purpose as the structural facing of the wall is provided by baskets or wrapped geotextile fabrics. The panels serve as a weather resistant barrier and can incorporate a variety of architectural appearances.

MSE retaining walls consist of granular soil reinforced by layers of soil reinforcement. The soil reinforcement resists lateral earth loads through friction against the granular soil. Soil reinforcement material properties conform to performance specifications. Internal stability is provided by soil reinforcement of sufficient length and strength for a chosen spacing within the parameters of the performance specifications. The reinforced soil functions as a gravity retaining wall system. External stability evaluations are conducted for the Strength I Limit State, Extreme Event I Limit State, and Extreme Event II Limit State evaluations, including checks of bearing resistance, location of the resultant force, and sliding resistance. Performance for settlement and/or deformations are evaluated for the Service I Limit State, including service applied bearing pressure, compared to the service bearing resistance that was correlated to acceptable settlement criteria. Retaining wall heights that result in service applied bearing pressures within the service bearing resistance that was correlated to settlement criteria, do not require deep foundation solutions.

The facing provides weather resistance and resists lateral soil loads between soil reinforcement layers. Full height precast concrete panel facings require more temporary bracing than multiple precast concrete panels. Full height precast concrete panel facings are less accommodating of settlement magnitude, and differential settlement, compared to multiple precast concrete panels.

A coping accommodates a sloping top of wall profile. A bridge rail is accommodated on top of the wall by incorporation of a reinforced concrete rail anchoring slab.

Construction time is relatively short, construction details and assembly require more temporary bracing, and multiple MSE suppliers are available.

During final design, plans and specifications are developed to give MSE suppliers the parameters and requirements for soil reinforcement. Prior to implementation of LRFD design, CDOT MSE wall worksheets and non-LRFD special provisions are used to define those parameters and requirements for soil reinforcement. For LRFD design, MSE wall details corresponding to LRFD, and special provisions corresponding to LRFD, are used.

The following are advantages to MSE wall with full-height precast concrete face:

- Somewhat low cost solution for most wall design heights.
- Accommodate various horizontal and vertical alignments, except tight curves.
- Experienced contractors and available suppliers.
- Shallow foundations, no foundation improvement needed.

The following are disadvantages to MSE wall with full-height precast concrete face:

- Geometric constraints for horizontal vertical alignments with tight curves are not accommodated as well with MSE walls.
- All retaining walls experience some settlement and lateral deformation, which must be compared to the project tolerances for settlement and lateral deformation.
- Differential settlement should be controlled to limit damage to face.
- Foundation improvement needed if strength factored bearing pressures exceed factored bearing resistance of in-place foundation material, or if service applied bearing pressures exceed bearing resistance that was correlated to settlement performance, often occurring on tall walls.
- Full height precast concrete panel facings are less accommodating of settlement magnitude, and differential settlement, compared to multiple precast concrete panels.

3.4.3.1.3. Reinforced concrete cantilever retaining wall

Reinforced concrete cantilever retaining walls function as a semi-gravity retaining wall to resist lateral soil loads by structural resistance of the stem and footing, external stability of the height, and width of soil retained. The footing dimensions are determined from external stability, and then designed to resist the structural loads. External stability evaluations are conducted for the Strength I Limit State, Extreme Event I

Limit State, and Extreme Event II Limit State evaluations, including checks of bearing resistance, location of the resultant force, and sliding resistance. Performance for settlement and/or deformations are evaluated for the Service I Limit State, including service applied bearing pressure, compared to the service bearing resistance that was correlated to acceptable settlement criteria.

Retaining wall heights that result in service applied bearing pressures within the service bearing resistance that was correlated to settlement criteria, do not require deep foundation solutions. Tall retaining walls generate large lateral soil loads and large resulting bearing pressures, sometimes requiring deep foundations to achieve external stability.

Construction cost of cantilever retaining walls over 10 feet high often exceeds the cost of MSE walls of similar height.

The following are advantages to reinforced concrete cantilever retaining wall:

- Lower lateral deformation than MSE walls (similar settlement compared to MSE walls).
- Accommodate various horizontal and vertical alignments.
- Experienced contractors and available suppliers.

The following are disadvantages to reinforced concrete cantilever retaining wall:

- Higher structure cost for tall walls.
- Longer construction duration.

3.4.3.1.4. Structure types not feasible

Vertical cantilever walls, such as secant pile walls, are not feasible for fill walls because they are typically used in cut configurations.

Gravity walls or modular block walls are not feasible for retaining walls over 8 feet high due to limited capacity to resist lateral soil loads resulting from tall walls.

MSE walls with block face constructed in Colorado in the last 20 years have experienced durability issues. The blocks comprising the face have deteriorated on several projects and at the request of the region are not to be used for walls for maintenance purposes except where approved.

3.4.3.1.5. Recommended structure type

Feasible structure types were evaluated as a solution for the structure configurations. Feasible structure type alternatives were evaluated to conform to and to accommodate the structure configuration according to the evaluation criteria. Various aspects of each alternative were evaluated, corresponding to the written descriptions in previous subsections.

Efficiencies in cost and schedule will be achieved with the recommended retaining wall type for fill walls with adequate service bearing resistance:

- **MSE retaining wall with precast concrete face:**
This alternative represents the least cost solution, accommodates settlement, accommodates some differential settlement, achieves performance within service parameters, conforms to the geometric constraints, and uses efficient construction. Figure 3.14 shows the recommended retaining wall type.

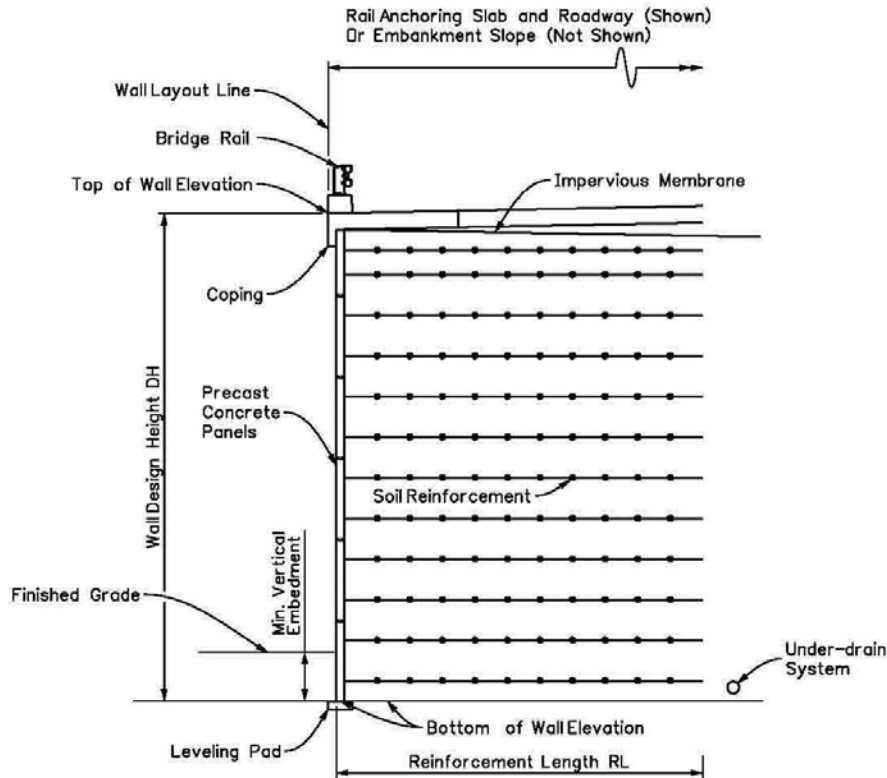
Figure 3.14 MSE wall with precast concrete face

3.4.3.2. Fill walls without adequate service bearing resistance

Retaining walls where the service bearing resistance is exceeded by the applied service bearing pressure will not perform within an acceptable range of settlement and deformation, unless a foundation solution is provided. Foundation solution alternatives include deep foundations, foundation improvements, monitored time consolidation, and load reduction, such as structural-grade polystyrene.

Retaining wall height is the main parameter that affects applied service bearing pressure. Tall retaining walls generate large lateral soil loads and large resulting bearing pressures, sometimes requiring deep foundations to achieve external stability. Foundation width or retaining wall type have minor affect on applied service bearing pressure.

The Service I Limit State will predominately control retaining wall foundations. The Strength I Limit State rarely controls retaining wall design.

Feasible structure types were considered and evaluated as a solution for retaining wall fill configurations without adequate service bearing resistance. Feasible structure type alternatives were evaluated to conform to and to accommodate the structure configuration according to the evaluation criteria. These structure types require deep foundations or other foundation solutions.

3.4.3.2.1. MSE wall with precast concrete face, with foundation improvement

MSE retaining walls consist of granular soil reinforced by layers of soil reinforcement. The soil reinforcement resists lateral earth loads through friction against the granular soil. Soil reinforcement material properties conform to performance specifications. Internal stability is provided by soil reinforcement of sufficient length and strength for a chosen spacing within the parameters of the performance specifications. The reinforced soil functions as a gravity retaining wall system. External stability evaluations are conducted for the Strength I Limit State, Extreme Event I Limit State, and Extreme Event II Limit State evaluations, including checks of bearing resistance, location of the resultant force, and sliding resistance. Performance for settlement and/or deformations are evaluated for the Service I Limit State, including service applied bearing pressure, compared to the service bearing resistance that was correlated to acceptable settlement criteria. Retaining wall heights that result in service applied bearing pressures that exceed the service bearing resistance that was correlated to settlement criteria, require deep foundation solutions or foundation improvement.

Foundation solution alternatives include deep foundations, such as stone columns, driven piles, dynamic compaction, compaction grouting, grout injection of the foundation soil to improve its service bearing resistance, or load reduction such as structural-grade polystyrene.

The facing provides weather resistance and resists lateral soil loads between soil reinforcement layers. Vertical joints between facing panels should be aligned so that the vertical joints run from top to bottom of wall to best accommodate differential settlements and deformations along the wall. A coping accommodates a sloping top of wall profile. A bridge rail is accommodated on top of the wall by incorporation of a reinforced concrete rail anchoring slab.

Construction time is relatively short; construction details and assembly are fairly simple; and multiple MSE suppliers are available.

During final design, plans and specifications are developed to give MSE suppliers the parameters and requirements for soil reinforcement. Prior to implementation of LRFD design, CDOT MSE wall worksheets and non-LRFD special provisions were used to define those parameters and requirements for soil reinforcement. For LRFD design, MSE wall details corresponding to LRFD, and special provisions corresponding to LRFD, are used.

The following are advantages to MSE walls with precast concrete face, with foundation improvement:

- Accommodate various horizontal and vertical alignments, except tight curves.
- Experienced contractors and available suppliers.

The following are advantages to MSE wall with precast concrete face, with foundation improvement:

- Cost of foundation improvement if strength factored bearing pressures exceed factored bearing resistance of in-place foundation material, or if service applied bearing pressures exceed bearing resistance that was correlated to settlement performance, often occurring on tall walls.
- Geometric constraints for horizontal vertical alignments with tight curves are not accommodated as well with MSE walls.
- All retaining walls experience some settlement and lateral deformation, which must be compared to the project tolerances for settlement and lateral deformation.
- Differential settlement should be controlled to limit damage to face.

3.4.3.2.2. MSE wall with precast concrete face, monitored time consolidation

MSE retaining walls consist of granular soil reinforced by layers of soil reinforcement. The soil reinforcement resists lateral earth loads through friction against the granular soil. Soil reinforcement material properties conform to performance specifications. Internal stability is provided by soil reinforcement of sufficient length and strength for a chosen spacing within the parameters of the performance specifications. The reinforced soil functions as a gravity retaining wall system. External stability evaluations are conducted for the Strength I Limit State, Extreme Event I Limit State, and Extreme Event II Limit State evaluations, including checks of bearing resistance, location of the resultant force, and sliding resistance. Performance for settlement and/or deformations are evaluated for the Service I Limit State, including service applied bearing pressure, compared to the service bearing resistance that was correlated to acceptable settlement criteria. Retaining wall heights that result in service applied bearing pressures that exceed the service bearing resistance that was correlated to settlement criteria, require foundation solutions.

Foundation solution alternatives include monitored time consolidation, or other foundation improvement alternatives.

The alternative with monitored time consolidation requires a different facing solution, such as a two-stage facing. A two-stage facing could be a wire-face MSE wall with a precast or cast-in-place reinforced concrete facing constructed later after the monitored consolidation has occurred. The inner facing resists lateral soil loads between soil reinforcement layers. The permanent outer facing provides weather resistance.

A coping accommodates a sloping top of wall profile. A bridge rail is accommodated on top of the wall by incorporation of a reinforced concrete rail anchoring slab.

Construction time is very long for the monitored time consolidation, potentially 6 months to 12 months.

The following are advantages of MSE walls with precast concrete face, monitored time consolidation:

- Potentially least cost solution for most wall design heights.
- Accommodate various horizontal and vertical alignments, except tight curves.
- Experienced contractors and available suppliers.

The following are disadvantages of MSE walls with precast concrete face, monitored time consolidation:

- Time for monitored consolidation, potentially 6 months to 12 months.
- Cost associated with monitored time consolidation.
- Geometric constraints for horizontal vertical alignments with tight curves are not accommodated as well with MSE walls.

3.4.3.2.3. Reinforced concrete cantilever retaining wall on deep foundation

Reinforced concrete cantilever retaining walls function as a semi-gravity retaining wall to resist lateral soil loads by structural resistance of the stem and footing by external stability of the height and width of soil retained. The footing dimensions are determined from external stability with consideration of the deep foundation. External stability evaluations are conducted for the Strength I Limit State, Extreme Event I Limit State, and Extreme Event II Limit State evaluations for the deep foundation. Performance for settlement and/or deformations are evaluated for the Service I Limit State, and provided by the deep foundation.

Foundation solution alternatives include driven steel piles or drilled caissons.

Construction cost of cantilever retaining walls over 10 feet high often exceeds the cost of MSE walls of similar height.

The following are advantages to reinforced concrete cantilever retaining walls on deep foundation:

- Lower lateral deformation than MSE walls.
- Accommodate various horizontal and vertical alignments.
- Experienced contractors and available suppliers.

The following are disadvantages to reinforced concrete cantilever retaining walls on deep foundation:

- Higher structure cost for deep foundations and for tall walls.
- Longer construction duration.

3.4.3.2.4. Structure types not feasible

Vertical cantilever walls are not feasible for fill walls because they are typically used in cut configurations.

Gravity walls or modular block walls are not feasible for retaining walls over 8 feet high due to limited capacity to resist lateral soil loads resulting from tall walls.

MSE walls with block face constructed in Colorado in the last 20 years have experienced durability issues. The blocks comprising the face have deteriorated on several projects.

3.4.3.2.5. Recommended structure type

Feasible structure types were considered and evaluated as a solution for the structure configurations. Feasible structure type alternatives were evaluated to conform to and to accommodate the structure configuration according to the evaluation criteria. Various aspects of each alternative were evaluated, corresponding to the written descriptions in previous subsections.

There are not enough known parameters related to foundations or construction available for time consolidation to complete an evaluation or make a structure type recommendation.

If significant construction time, such as 6 months to 12 months, is available to accommodate a long time consolidation, this alternative could be feasible for fill walls without adequate service bearing resistance:

- **MSE retaining wall with precast concrete face, monitored time-consolidation.**
This alternative represents the potentially least cost solution, but requires a long duration, such as 6 months to 12 months, for monitored time consolidation. It accommodates some differential settlement,

achieves performance within service parameters, conforms to the geometric constraints, and uses efficient construction. Figure 3.15 shows the recommended structure type.

Figure 3.15 MSE wall with precast concrete face monitored time-consolidation

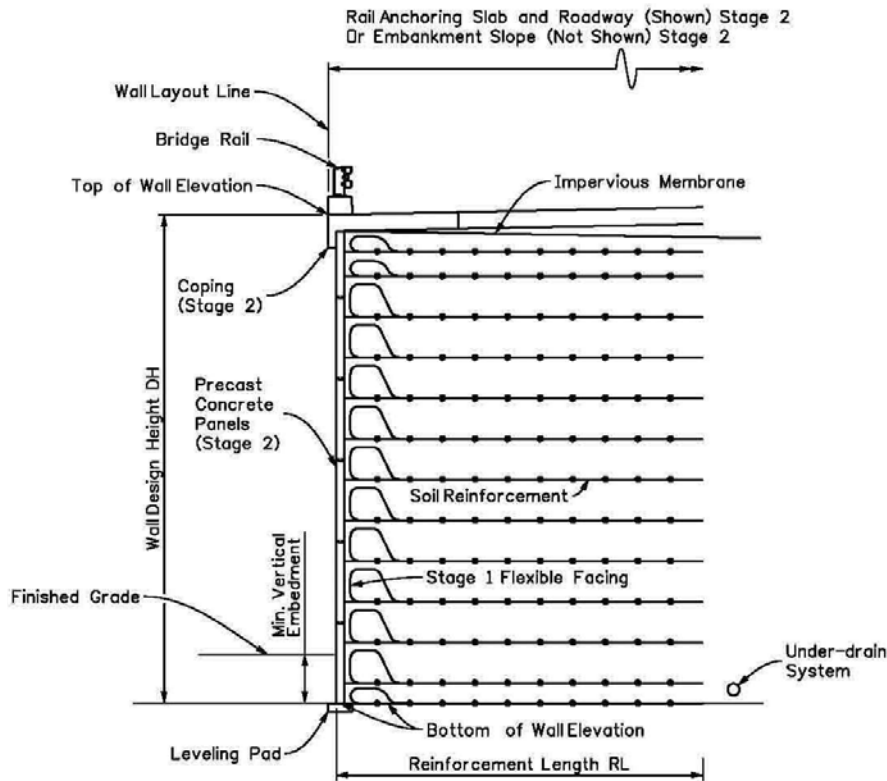

If significant construction time is not available to accommodate a long time-consolidation, this alternative could be feasible:

- MSE retaining wall with precast concrete face, with foundation improvement.**
 This alternative represents the potentially least cost solution, but requires a foundation solution such as deep foundation, stone columns, driven piles, grout injection of the foundation soil to improve its service bearing resistance, or a load reduction such as structural-grade polystyrene, or other foundation improvement alternatives. Figure 3.16 shows the recommended structure type.

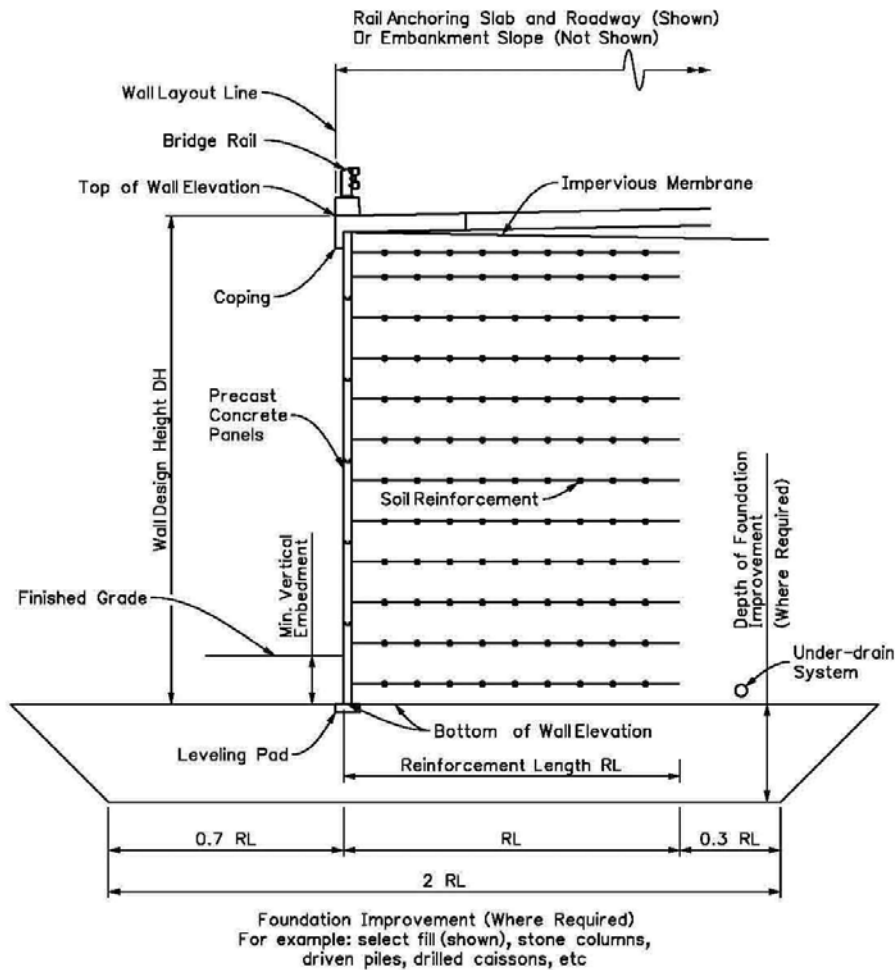
Figure 3.16 MSE wall with precast concrete face with foundation improvement

3.4.3.3. Cut walls

Retaining walls in cut configuration are a configuration where the retaining walls support an existing surface to accommodate a lower surface in front of the retaining walls, such as a proposed roadway in front of an existing surface. Cut configuration retaining walls could be used to support an existing roadway surface to accommodate a proposed surface at a lower elevation in front of the retaining wall. Cut configuration retaining walls could be used to support an existing abutment embankment to accommodate a widened roadway under the bridge.

Top-down construction is one technique for construction of cut retaining walls. This method includes the following:

- Embedded vertical cantilever walls such as secant pile walls, sheet piling walls, soldier piling with lagging walls.
- Multi-anchor facing soil nail walls or other anchored wall systems such as soldier pile walls with lagging and anchors.

Feasible structure types were considered and evaluated as a solution for retaining wall cut configurations. Feasible structure type alternatives were evaluated to conform to and to accommodate the structure configuration according to the evaluation criteria.

3.4.3.3.1. Embedded vertical cantilever retaining wall

Embedded vertical cantilever retaining walls function as non-gravity retaining walls to resist lateral soil loads by structural resistance of the vertical elements and by the passive lateral resistance of competent rock against the embedded vertical cantilever. The embedded vertical cantilever elements would be drilled caissons embedded in bedrock. The vertical cantilever elements above the foundations would be formed

reinforced concrete columns of similar diameter, to facilitate reinforcement splicing from the drilled caissons to the vertical columns. External stability evaluations are conducted for the embedded vertical cantilever caissons, to compare lateral resistance to the applied loads using the Strength I Limit State provisions. Lateral deflections are evaluated for the Service I Limit State, including deflections of the upper vertical cantilever components, and lateral soil resistances that are correlated to service performance of the foundation.

Where the bottom of wall is lower than estimated top of bedrock, the embedded vertical foundation members are drilled directly into bedrock. If the upper vertical cantilever elements are above existing ground, the upper vertical cantilever elements would be constructed as formed reinforced concrete columns above the foundation caissons.

Where the bottom of wall is above estimated bedrock, the embedded vertical foundation members require more length to reach embedment in bedrock, and require a larger diameter to achieve more stiffness due to the depth to fixity. The deflection of the upper cantilever elements is affected by the longer depth to fixity of the foundation elements, and requires large elements to limit deflections, using the Service I Limit State provisions.

Embedded vertical cantilever retaining walls require 12 feet to 15 feet construction platform width. A foundation drill rig could operate on the construction platform, proceeding along the wall length, but the speed of the foundation construction will be slow due to drilling many caissons into bedrock, and the sequence to drill a few holes and place reinforced concrete caissons. Where more width is available, the drill rig could work from the side of the retaining wall, which is a more efficient sequence.

The upper vertical cantilever elements would be reinforced concrete columns to accommodate connection to the foundations. Then a facing would be constructed to span between vertical columns. The visible surface of the facing can accommodate architectural and aesthetic designs obtained by a formliner. Compared to the reinforced concrete stem wall of the reinforced concrete cantilever wall alternative, the upper vertical reinforced concrete columns with next-step facing is less efficient.

The following are advantages and disadvantages of embedded vertical cantilever retaining walls:

- Can be constructed within construction platform width.
- Accommodates horizontal and vertical alignments.

The following are advantages and disadvantages of embedded vertical cantilever retaining walls:

- Medium cost solution, higher than lowest cost alternative.
- Longer construction duration than other alternatives.
- Construction duration is longer than other alternatives due to the many foundations to be drilled, and the additional step to construct facing after upper vertical columns are constructed.

3.4.3.3.2. Multi-anchored-facing soil nail retaining wall

Multi-anchored-facing retaining walls function as non-gravity retaining walls to resist lateral soil loads by structural resistance of multiple lateral anchor elements. The multiple lateral anchors are connected to a vertical facing that resists lateral soil loads between anchors. Soil nail retaining walls are common types of multi-anchor-facing retaining walls. The multiple soil nails resist intension the lateral soil loads.

Facing alternatives consist of reinforced concrete cast-in-place or two stage facings consisting of reinforced concrete cast-in-place first stage and precast concrete second stage facing. External stability evaluations are conducted for the multi-anchor wall system and individual soil nail anchors, plus the facing, using the Strength I Limit State provisions. Lateral deflections are evaluated for the Service I Limit State.

The following are advantages of multi-anchored-facing soil nail retaining walls:

- Potentially the least cost alternative.
- Constructed with top-down sequence from the accessible side.
- Accommodates horizontal and vertical alignments.

The following are disadvantages of multi-anchored-facing soil nail retaining walls:

- Medium cost solution, higher than lowest cost alternative.
- Potentially longer construction duration than other alternatives.
- Quality concerns of grout and facing.
- Length of anchors must be within right of way.

3.4.3.3.3. Structure types not feasible

Fill wall types, due to significant excavation and associated costs are not likely to be feasible.

3.4.3.3.4. Recommended structure type

Feasible structure types were considered and evaluated as a solution for the structure configurations. Feasible structure type alternatives were evaluated to conform to and to accommodate the structure configuration according to the evaluation criteria. Various aspects of each alternative were evaluated, corresponding to the written descriptions in previous subsections.

Efficiencies in cost and schedule will be achieved with the recommended retaining wall type for cut walls:

- **Multi-anchor-facing soil nail retaining wall with precast concrete face**
 This alternative represents the potentially least cost solution, conforms to the geometric constraints, and uses efficient construction.

Figure 3.17 Multi-anchor-facing soil nail retaining wall with precast concrete face

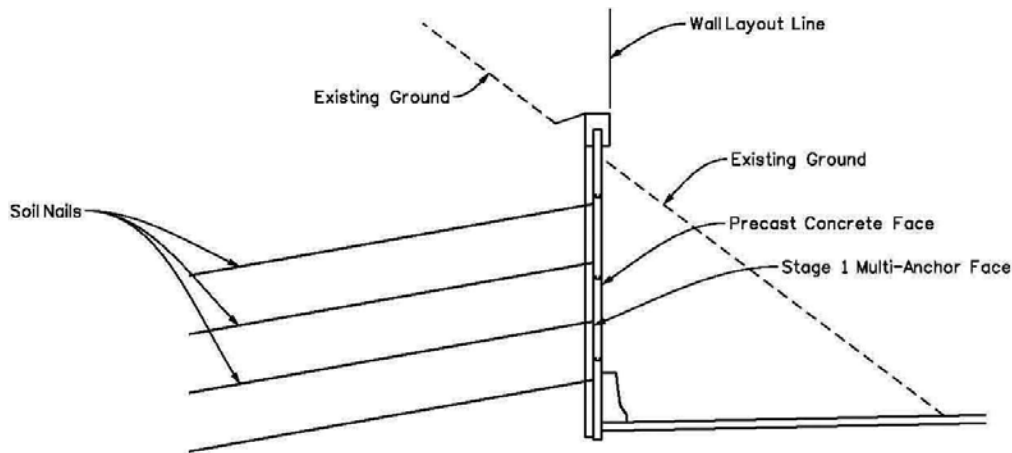

4. Accelerated bridge construction considerations

Over the past several years, CDOT has adopted the use of Accelerated Bridge Construction (ABC) technologies on a select basis for projects throughout the state. The basis for the use of ABC was primarily driven by the general guidelines referenced in the Federal Highway Administration's (FHWA) *Decision-Making Framework for Prefabricated Bridge Elements and Systems* document and the CDOT project team requirements.

In December 2012, CDOT's Project Development Branch issued their Accelerated Bridge Construction Design Bulletin, which provides general guidance for the implementation of ABC techniques on projects that contain one or more bridges. This document supports CDOT's commitment to ABC by acknowledging FHWA's Every Day Count initiatives, reducing maintenance of traffic (MOT), encouraging innovation and increasing safety to the travelling public and construction workers.

In general, the design bulletin includes several documents and outlines a two-phased approach to assist the project team with the determination of implementing ABC on their projects. The first phase is completed at the pre-scoping project stage incorporating average daily traffic (ADT) and other site constraints into the initial evaluation while a more in-depth evaluation is performed using FHWA's Analytic Hierarchy Process (AHP) software during the second phase. Note this second phase should include input from the specialty groups, project team, and Staff Bridge and occur before the field inspection review (FIR) design is complete. Refer to Appendix E for additional information.

4.1. Implementation

The North I-25 corridor offers numerous opportunities for implementing ABC technologies, ranging from the use of prefabricated bridge elements (i.e. precast girders, deck panels, pier caps) to the accelerated placement of bridge superstructure systems using slide-in or self-propelled modular transports. The costs associated with implementing these technologies are a function of its constructability and the resulting improvements in traffic impacts at the project site. See Figure 4.1 for a listing of typical ABC technologies.

Figure 4.1 Potential ABC technologies or methods

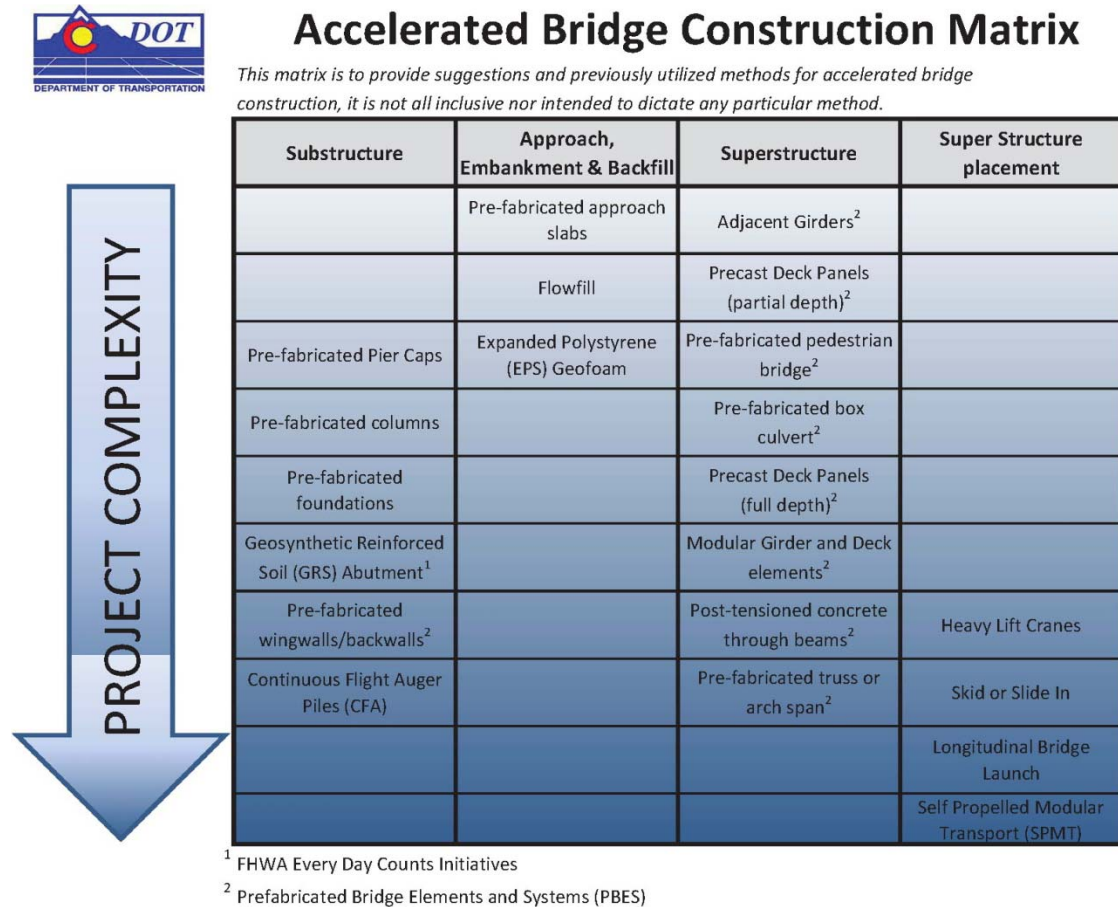

ABC technologies for the structures along the I-25 North corridor should be evaluated on a project-by-project basis considering:

- Average daily traffic (ADT)
- Delay/detour time
- Bridge importance
- User costs
- Economy of scale
- Safety
- Railroad impacts
- Site conditions

Note that these project constraints can vary for the structures along the I-25 North corridor and the decision to recommend ABC on these projects may originate from the CDOT's Accelerated Bridge Construction Design Bulletin, yet the final recommendation will most likely be based upon CDOT's I-25 North Program Management approach and the available financing opportunities.

In preparation for advanced construction packages and/or potential alternative delivery opportunities for the structures along this corridor, this report has identified baseline ABC criteria and components that should be evaluated within the development of the project site-specific structure type selection reports (see Table 4.1).

These features should be considered on a project basis to confirm the applicability to the site-specific structure selection requirements.

Table 4.1 Baseline ABC criteria and components for evaluation

Criteria/Component	Comment
I-25 North User Cost	CDOT has historically used lane rental fees to help establish user costs along I-25 North corridor. All projects within this corridor shall consider an average user cost of \$ x,xxx per day to help identify if ABC is a viable alternative.
National Certified Corrosion Expert	A corrosion engineering consulting firm with expertise in the prevention of corrosion for civil engineering structures shall be required to review the integrity of the proposed connection details for a 75 year design life. The results of this evaluation shall be submitted to CDOT in determining the acceptability of the proposed connection details.
75-year Design Life	All bridge designs shall satisfy CDOT Staff Bridge protocol to provide 75-year design lives.
Full-depth Precast Deck Panels	CDOT Staff Bridge has recently developed bridge worksheets that specify design requirements and provide recommended details for plan implementation.
Precast Bridge Rail	Insufficient data that support AASHTO’s LRFD TL-4 and 5 testing/design loading requirements should discourage the use of these components.
Field Welded Elements	In general, the field welding activities is discouraged; however, weld plates can be used only as temporary supports during erection and shall not be placed in a pre-stressed load path or prevent elements from seating properly.

This list represents only a fraction of the available ABC opportunities. Additional project-site innovation and/or ABC implementation is encouraged, as applicable, subject to final approval of the CDOT Region 4 Staff Bridge Design Unit Leader.

5. Structures design criteria

This section provides the design criteria to be adhered to when analyzing and designing structures along the I-25 corridor.

5.1. Design specifications

The following resources shall be used and adhered to for the design of structures:

- American Association of State Highway and Transportation Officials (AASHTO) *AASHTO LRFD Bridge Design Specifications* 6th Edition 2012.
- CDOT *Bridge Design Manual* July 2012 Edition with current revisions and technical memorandums
- CDOT *Computer Aided Design and Drafting Manual* 2005 Edition using the recently implemented standards for the Bentley Suite and the CDOT *Bridge Detail Manual* June 2012 Edition with current revisions
- CDOT *Bridge Rating Manual* 1995 with current revisions

5.2. Design method

All bridges, retaining walls, and structures other than the cast-in-place concrete box culvert designs that are in CDOT M&S Standards M-601-1, 2, and 3 shall be designed for applicable strength, service and extreme event limit states as defined by the load groups in the LRFD specifications. Culverts that don't conform to the CDOT standards, the culvert will be designed using the LRFD specifications.

5.3. Rating method

All bridges and box culverts with total spans greater than 20 feet shall be rated for applicable strength and service limit states as defined by the load groups in the LRFD specifications.

5.4. Design loads

The following loads shall be accounted for in the analysis and design of structures.

Permanent loads (DC, DW, EH, EV, ES, CR, SH)

Unit weight of reinforced concrete	150 lbs per cubic foot (pcf)
Unit weight of prestressed concrete	155 pcf
Unit weight of wearing surface (3 inch)	144 pcf
Unit weight of Structure Backfill (Class 1)	125 pcf
Unit weight of Structure Backfill (Class 2)	125 pcf

Horizontal earth loads (EH, ES)

Active Earth Pressure Coefficient K_a	0.2827 for Structure Backfill (Class 1 and 2)*
At-Rest Earth Pressure Coefficient K_o	0.4408 for Structure Backfill (Class 1 and 2)*
*Assuming a 34° friction angle	
In-situ soils determined in site-specific reports	

Live loads on bridge

HL-93 (Design Truck or Tandem with Design Lane Load)	
Colorado Permit Vehicle	
Live Load Deflection Criteria	= L/800 on structures without pedestrians = L/1000 on structures with pedestrians

Bridge rail

Bridge Rail Type 10M	600 lbs per linear foot (lb/LF) for two rails
Bridge Rail Type 7	1000 lb/LF for two rails

Fencing

To be determined in site-specific reports.

Thermal forces (TU, TG, FR)

Thermal Coefficient	0.0000006/°F Concrete, 0.0000065/°F Steel
Temperature Range Concrete	105 °F, 45 °F Rise and 60 °F Fall
Temperature Range Steel	120 °F, 50 °F Rise and 70 °F Fall

Note: The temperature rise is for erection on a 30 °F day and the temperature drop is for erection on a 90 °F day.

Crep and shrinkage (CR, SH 3, FR)

In accordance with AASHTO LRFD Bridge Design Specifications.

Seismic parameters

To be determined in site-specific reports.

Vehicle collision

All columns for bridges over roadway features shall be designed to resist vehicular collision. Retaining wall and bridge abutments with any element existing within the clear zone of the adjacent roadway shall be designed to resist vehicular collision.

5.5. Materials

The materials presented below shall be the standard materials for structures along the corridor unless specifically approved by CDOT.

Precast Prestressed Concrete	Class S, f'c = 8500 lbs per square inch (psi) (max) 6500 psi (min)
CIP Reinforced Concrete	Class D, f'c = 4500 psi
Post-Tensioned Concrete	Class S35, f'c = 5000 psi
Reinforcing Steel	ASTM A-615, Grade 60
Drilled Caissons	Class BZ, f'c = 4000 psi
Prestressing Strand	AASHTO M 203M or M203, 270 ksi
Structural Steel	AASHTO M270 Grade 50 (ASTM A-572)

5.6. Safety specifications

Designers shall identify all safety critical work via the CDOT Project Special Provision: Revision of Section 107 Performance of Safety Critical Work at each project milestone, including FIR and final office review (FOR) submittals.

5.7. Life cycle cost analysis

Text TBD.

6. Common bridge maintenance items

For bridges and structures some details and specifications can be standardized throughout the North I-25 corridor to simplify the construction and maintenance. The following items will be standards along the corridor and shall be required where applicable. These standard details and specifications can be found in Appendix B.

6.1. Bridge deck drains

In general, the design for bridge deck drainage should be in accordance with chapter 16 of the CDOT BDM with the following additions:

- Bridge drains are to be sized using a design storm intensity, $i = 4$ inches per hour, which represents a viable upper limit from a driver's safety perspective.
- Deck drains through the bridge deck should be avoided as much as practical from a design perspective. Approach slab inlet drains have proven effective and require little maintenance (see Appendix B). Approach slab inlets should be located on the low approach slab end prior to the approach slab expansion joint.
- Deck drainage and/or bridge scuppers, when required by design, should incorporate the following maintenance considerations:
 - CDOT Region 4 maintenance prefers a closed-system in lieu of the open trench system. This preference is driven by the Vactor truck equipment now available for cleaning "stormceptors" and bridge deck drainage piping systems.
 - Design the slope on bridge deck drain pans and drain lines to be self-flushing for sediments. This should avoid observed clogging problems with commercially available products. Custom designed drain pans may be required.

6.2. Bridge approach drains

Approach drains will be used to capture roadway flows prior to crossing bridge expansion joints to minimize the corrosion potential associated with water leaking through the joints. These drains consist of cast iron vane grates and concrete inlet boxes cast into the approach slab. The movement interface between the inlet box and the surrounding fill is accommodated with low-density, polystyrene around the exterior perimeter of the inlet box. The movement interface between the vertical rigid pipe outfall and the pipe embedded in the fill is handled by oversizing the embedded pipe as required to accommodate the movements. See Appendix B for bridge approach drains details.

6.3. Bridge rail – duplex coating

The Type 10M bridge railing will be both galvanized and painted to provide a double layer of corrosion protection. Paint color can vary to fit unique aesthetic requirements of each site if required. CDOT Region 4 Staff Bridge has developed a project special specification covering the technical requirements of painting after galvanizing. See Appendix B for bridge rail – duplex coating details.

6.4. Fencing

For structures over I-25, snow fencing will consist of tight mesh chain link fence. The fence mesh shall be powder coated black. A special 68-inch high fence compatible for use in combination with the Type 10M bridge railing will be developed. For railroad crossings, in accordance with Region 4 maintenance preferences for Type 10M bridge rail, a tight mesh chain link fence will be used with a total height of 120 inches in conjunction with a Type 10M bridge railing. The fence posts are mounted to the back of the W8x18 bridge rail posts. The fence mesh shall be powder coated black. See Appendix B for fencing details.

6.5. Anti-icing systems

Specific site conditions that might make good candidates for an anti-icing system include severe roadway geometrics or perhaps creek crossings where bridge decks freeze more quickly than the approach roadways. In general, these systems are expensive and therefore require a specific trigger, such as a documented accident history due to ice, to justify the \$500,000 initial expense to install the system on a typical bridge structure.

6.6. Bridge deck durability

Bridge deck longevity is of paramount importance to the region. Decks with waterproofing membranes and asphalt overlays have exhibited superior performance system-wide; therefore, all bridges shall be provided with waterproofing membranes and asphalt overlays, including I-25 mainline structures. This will result in asphalt "islands" within the proposed concrete pavement typical section throughout the corridor, but Staff Bridge believes this will result in the lowest total maintenance burden for the region. All bridge decks shall be designed to be replaceable without the need for future shoring that would restrict laneage of the undercrossing roadway(s).

6.7. Expansion joints

Expansion joints shall be placed at the ends of the approach slabs for integral bridges. Expansion joint devices shall typically be of the armored variety that use elastomeric glands within machined steel headers. The elastomeric glands can be easily replaced in the future when needed. It is anticipated that single-gland joints with 0- to 4-inch movement capacity will work at most locations within the corridor and are the preferred joint type.

6.8. Bearings

The use of bearings will be minimized by integral structural connections between superstructure and substructure. Where bearings are required, Type I elastomeric bearing devices are preferred over Type II elastomeric bearing devices. Type III bearing devices (pot or disc) shall not be used without CDOT Staff Bridge approval.

6.9. Access hatches

Closed girder sections will use soffit access hatches to allow for inspection of the interior of the bridge girders where tub or box girders have an inside depth of 5 feet 0 inch or greater. Access hatches shall be positioned strategically for easy access from the ground via extension ladders. Holes for egress through interior pier diaphragms are preferred to minimize the number of access hatches required. Access hatches shall consist of aluminum doors hinged to open into the girder void space. Minimum opening size shall be 2 feet 0 inch by 3 feet 0 inch. Galvanized steel framing and hardware shall be used. A ladder hanger bar shall be provided to ensure safety for inspectors. A recessed padlock shall be provided.

6.10. Under-bridge lighting

Under-bridge lighting will only be required on structures crossing over railways in accordance with typical railway preferences and guidelines. The need for under-bridge lighting beneath overcrossings and within interchange areas shall be assessed individually for each respective site, taking into account the potential benefits of providing such lighting versus the feasibility of providing the lighting. Lighting fixtures shall preferably be attached to bridge substructures rather than bridge superstructures.

6.11. Electrical conduit in bridge rails

It is the policy of CDOT Region 4 to provide one 2-inch diameter rigid metal conduits in all bridge rails on the tension side of the curb as a contingency for future installation of electrical or communication utilities.

6.12. Sidewalk curbs and treatments

Sidewalks on bridges shall receive a final transverse broom finish and shall have an applied coating of concrete sealer. The minimum curb height above the roadway surface will be 6 inches.

6.13. Barrier separations for pedestrians

Follow CDOT BDM regarding barrier separation for design speeds greater than 45 miles per hour (mph). A Type 7 barrier shall be used.

6.14. Stain versus coating

CDOT Region 4 prefers concrete stain without anti-graffiti coating over concrete coatings. Structures shall be treated with structural concrete stain of the appropriate color(s) in accordance with CDOT Standard Specification 601.

6.15. Color theme

A two-tone color scheme consisting of light and dark earth tones in combination with a third, contrasting accent color will be used to give the corridor an identity. Specific colors will be determined as the project develops.

Table 6.1 Base standard color palette

Item	Color
Abutments and wingwalls	Beige concrete stain to match federal color # 22648
Piers	Beige concrete stain to match federal color # 22648
Slope paving	Light brown concrete stain to match federal color # 20252
Retaining walls – concrete block	Beige concrete stain to match federal color # 22648
Retaining walls – concrete	Beige concrete stain to match federal color # 22648
Retaining walls – MSE	Beige concrete stain to match federal color # 22648
Retaining walls – dry stack rock	Beige neutral tone palette
Girders	Burgundy concrete stain match federal color # 20252
Steel pedestrian bridge	Dark tan paint to match federal color # 30324
Bridge rail – concrete	Beige concrete stain to match federal color # 22648
Bridge rail – steel – type 10M	Galvanized steel with duplex coating to match federal color #XXXX

Where concrete stain is not used, a Class 1 concrete finish is recommended to be used.

Appendix C

*General Layout, Typical Section, and Phasing
for Proposed Bridges*

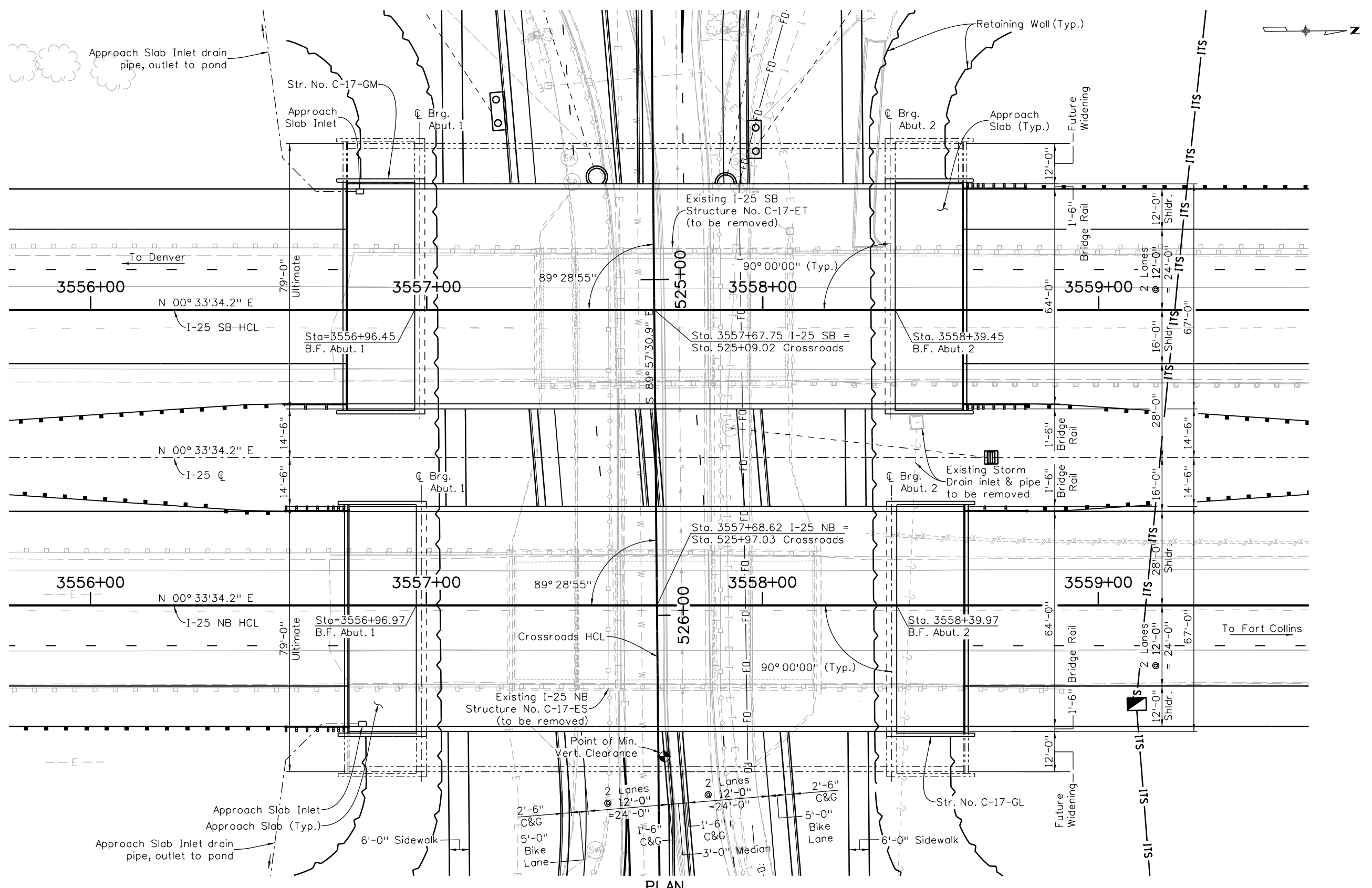

PLAN

Design		Detail		Quantities	
INITIAL	DATE	INITIAL	DATE	INITIAL	DATE
Designed By	12/14	Checked By	05/15	Checked By	
Checked By		Checked By		Checked By	

Print Date: 6/30/2015
File Name: 20575_BRDG_GLO1.dgn
Horiz. Scale: NTS Vert. Scale: As Noted
Staff Bridge Branch - Unit 0224 Unit Leader: AJP

Sheet Revisions		
Date:	Comments	Init.

Colorado Department of Transportation

2207 East Highway 402
 Loveland, CO 80537
 Phone: 970-622-1268 FAX: 970-669-0289

Region 4 JFF

As Constructed
No Revisions:
Revised:
Void:

CROSSROADS BRIDGE REPLACEMENT I-25 OVER CROSSROADS GENERAL LAYOUT (1 OF 2)			
Designer:	P. Stein	Structure Numbers	C-17-GL
Detailer:	R. Dillon	Structure Numbers	C-17-GM
Sheet Subset:	BRIDGE	Subset Sheets:	B03 of 4

Project No./Code
IM 0253-242
20575
Sheet Number

ricdl 12:01:02 PM c:\pwworking\vaecom\00\340630\20575_BRDG_GLO1.dgn

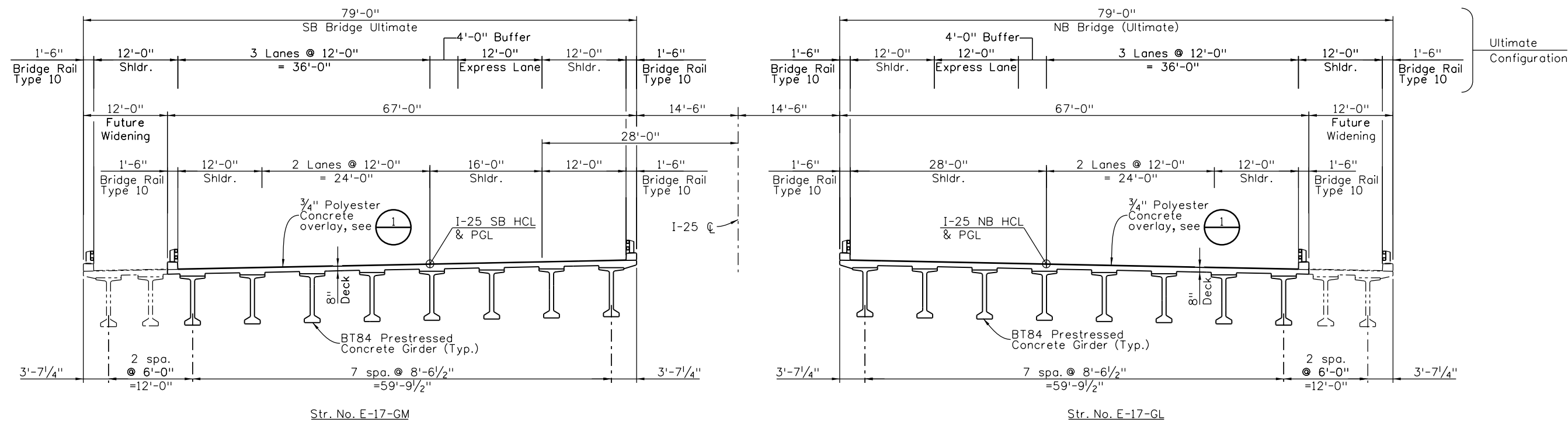

TYPICAL SECTION
(Looking North)

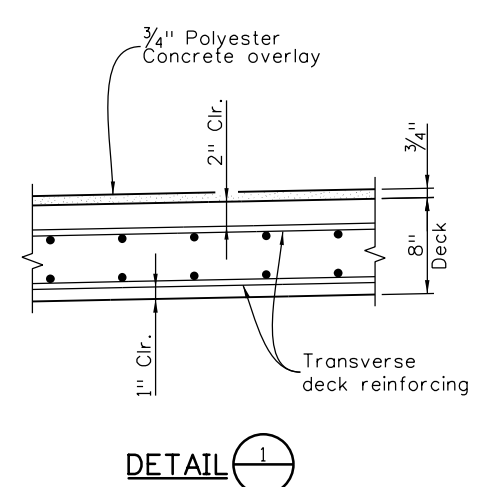

DETAIL 1

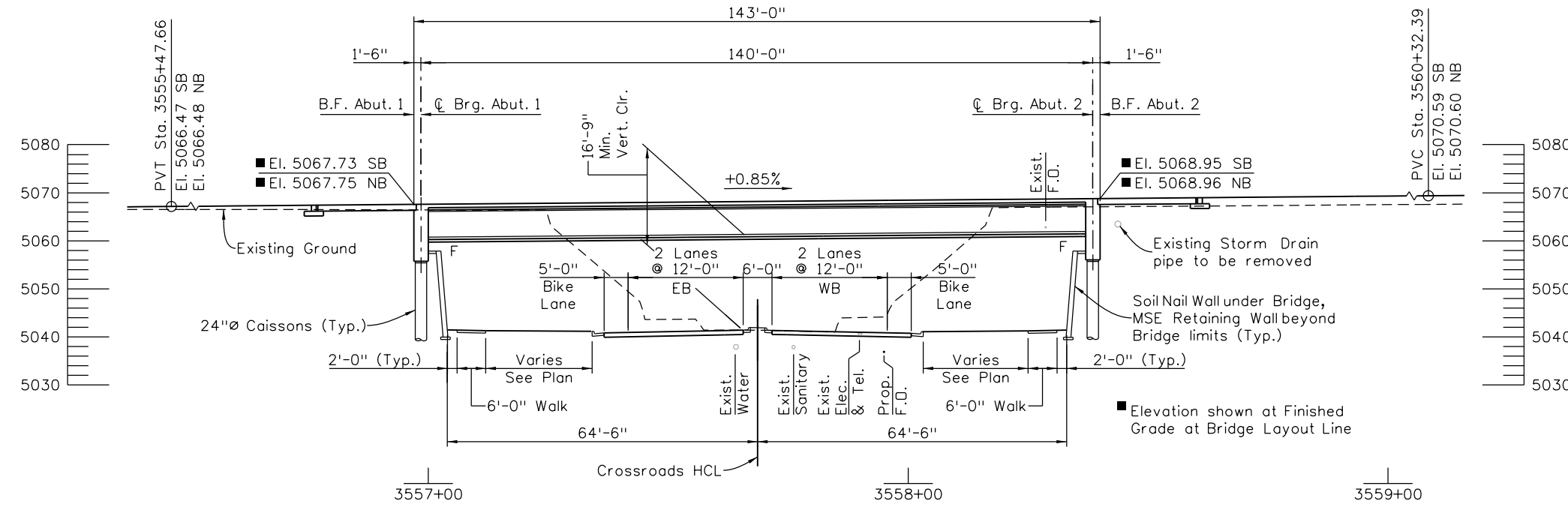

SECTION
(Taken at I-25 NB HCL, SB Bridge Similar)

Design		Detail		Quantities	
DATE	INITIAL	DATE	INITIAL	DATE	INITIAL
12/14	CAJ	05/15	PRS	05/15	PRS
Designed By	Checked By	Detailed By	Checked By	Quantities By	Checked By

Print Date: 6/30/2015
 File Name: 20575_BRDG_GLO2.dgn
 Horiz. Scale: NTS Vert. Scale: As Noted
 Staff Bridge Branch - Unit 0224 Unit Leader: AJP

Sheet Revisions		
Date:	Comments	Init.

Colorado Department of Transportation

2207 East Highway 402
 Loveland, CO 80537
 Phone: 970-622-1268 FAX: 970-669-0289

Region 4 JFF

As Constructed
 No Revisions:
 Revised:
 Void:

CROSSROADS BRIDGE REPLACEMENT I-25 OVER CROSSROADS GENERAL LAYOUT (2 OF 2)			
Designer:	P. Stein	Structure	C-17-GL
Detailer:	R. Dillon	Numbers	C-17-GM
Sheet Subset:	BRIDGE	Subset Sheets:	B04 of 4

Project No./Code
 IM 0253-242
 20575
 Sheet Number



ricdl 12:01:09 PM c:\pwworking\vaecom00\dillon\40340630_20575_BRDG_GLO2.dgn

ricdl 12:00:57 PM c:\pwworking\acom00\rdillon\0340630_20575_BRDG_Phasing.dgn

Design		Detail		Quantities	
DATE	INITIAL	DATE	INITIAL	DATE	INITIAL
12/14	CAD	05/15	RAD	05/15	PRS
	Checked By		Checked By		Checked By
	Designed By		Checked By		Checked By

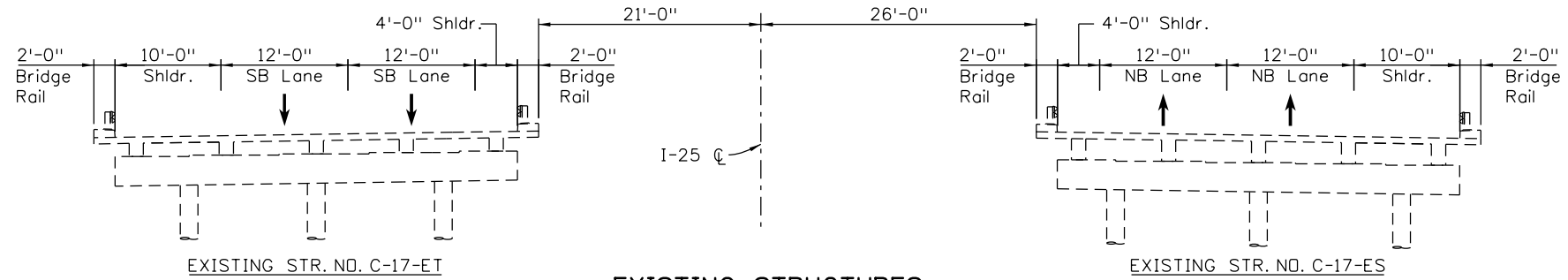

EXISTING STRUCTURES

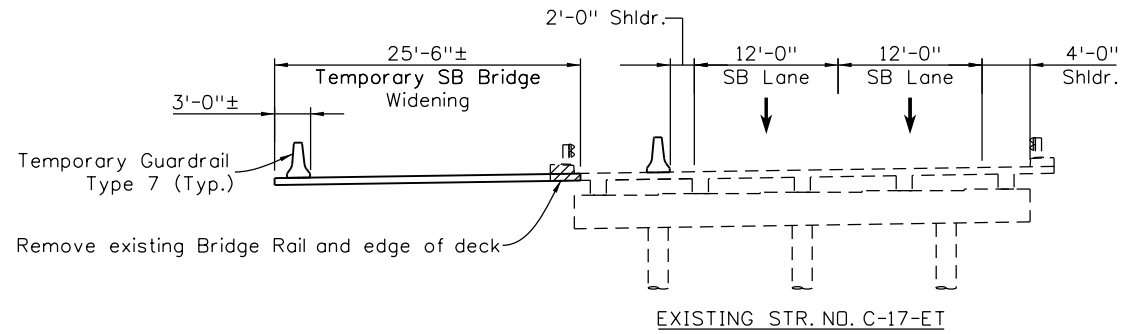

BRIDGE CONSTRUCTION PHASE 1

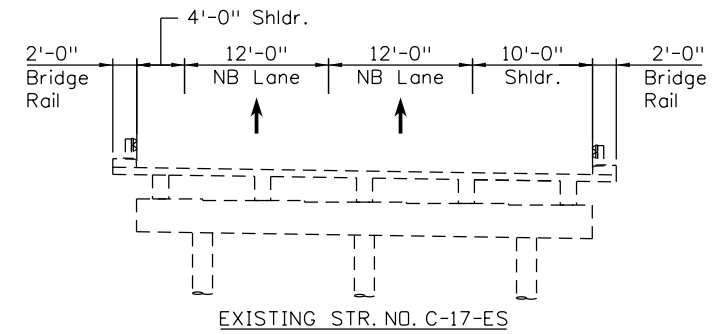

PHASE 1:
Shift Southbound traffic on existing SB bridge and construct temporary Southbound bridge widening

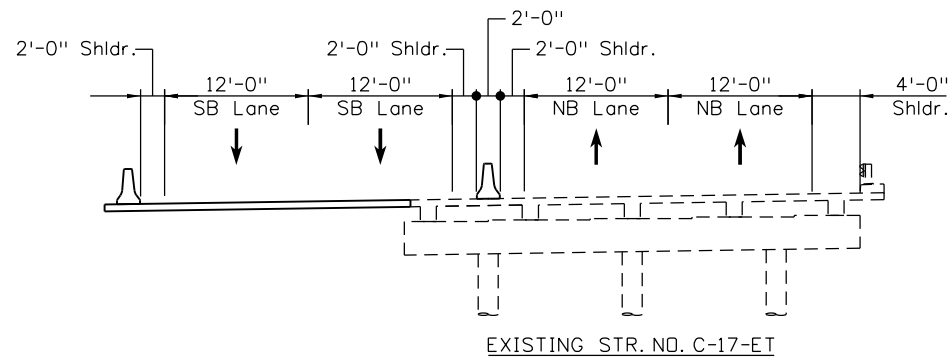

BRIDGE CONSTRUCTION PHASE 2

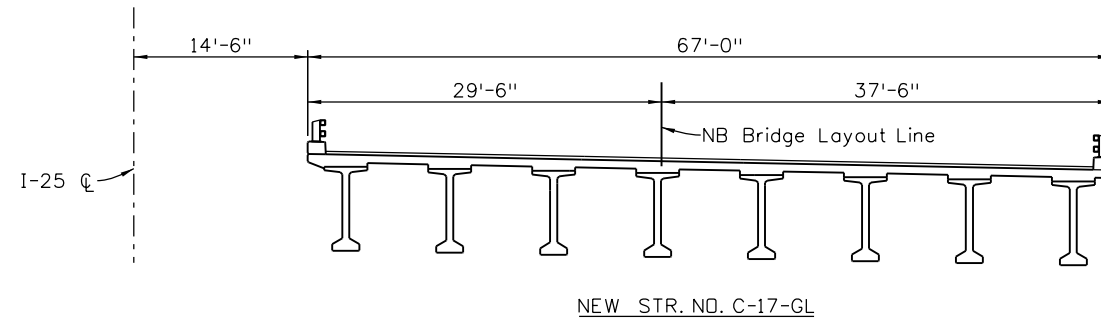

PHASE 2:
Move Northbound traffic onto widened SB bridge and construct new Northbound bridge

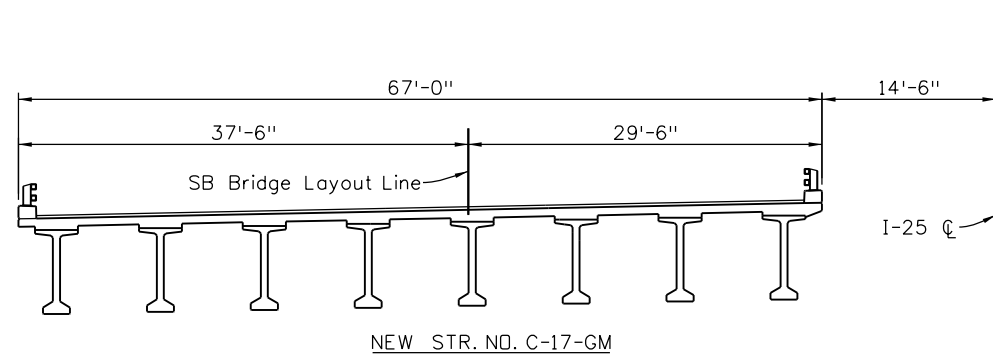

BRIDGE CONSTRUCTION PHASE 3

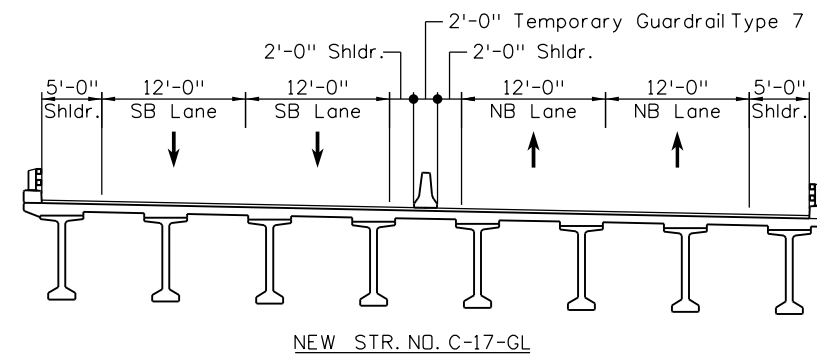

PHASE 3:
Move all traffic onto new Northbound bridge
Remove existing Southbound structure
Construct new Southbound bridge

Print Date: 6/30/2015		Sheet Revisions		
File Name: 20575_BRDG_Phasing.dgn		Date:	Comments	Init.
Horiz. Scale: NTS Vert. Scale: As Noted				
Staff Bridge Branch - Unit 0224 Unit Leader: AJP				
6300 South Syracuse Way Suite 600 Centennial, CO 80111 (303) 721-1440		Colorado Department of Transportation 2207 East Highway 402 Loveland, CO 80537 Phone: 970-622-1268 FAX: 970-669-0289 Region 4 JFF		

As Constructed		CROSSROADS BRIDGE REPLACEMENT		Project No./Code	
No Revisions:		I-25 OVER CROSSROADS		IM 0253-242	
Revised:		BRIDGE CONSTRUCTION PHASING		20575	
Void:		Designer: P. Stein	Structure Numbers: C-17-GL	Sheet Number	
		Detailer: R. Dillon	Subset Sheets: B02 of 4		
		Sheet Subset: BRIDGE			

As Constructed		CROSSROADS BRIDGE REPLACEMENT		Project No./Code	
No Revisions:		I-25 OVER CROSSROADS		IM 0253-242	
Revised:		BRIDGE CONSTRUCTION PHASING		20575	
Void:		Designer: P. Stein	Structure Numbers: C-17-GL	Sheet Number	
		Detailer: R. Dillon	Subset Sheets: B02 of 4		
		Sheet Subset: BRIDGE			