



COLORADO

Department of Transportation

Transportation Engineering Training Program (TETP)

Guardrail Systems Field Guide For Construction Engineers and Inspectors

v1.2—December 2021

Prepared by:
The Regis Company

Contents

Version information.....	3
Introduction.....	4
Intended audience.....	4
Where to get more information.....	4
CDOT MASH implementation.....	5
Major changes.....	5
Implementation policies.....	5
Current end anchorages.....	7
Summary.....	7
MFLEAT (Mash FLared Energy Absorbing Terminal).....	9
MSKT (Mash Sequential Kinking Terminal).....	10
MAX-Tension.....	11
SoftStop.....	12
End Anchorage Type 3B.....	13
End Anchorage Type 3D.....	14
End Anchorage Type 3K.....	15
Current transitions.....	16
Summary.....	16
Transition Type 3G.....	17
Transition Type 3H.....	18
Transition Type 3J.....	19
Current median terminals.....	20
Summary.....	20
MAX-Tension Median.....	21
End treatments that are no longer allowed.....	22
Summary.....	22
End anchorages and terminals.....	24
Transitions.....	32
Median terminals.....	33
Guardrail design review.....	36
Guardrail system design.....	36
Guardrail terminal systems.....	40
Resources.....	43
Glossary.....	43
Web links.....	45

Version information

V1.0 November 2018	Initial release
V1.1 March 2019	Updated to conform with the December 21, 2018 revision of Standard Plan M-606-1 and Project Special Detail D-606-2.
V1.2 December 2021	<p>Updated to conform with the March 5, 2020 revision of Standard Plan M-606-1 and Project Special Detail D-606-2.</p> <p>Per the Issuance Letter from Shawn Yu, Standards and Specifications Unit Manager:</p> <ul style="list-style-type: none">• The Standards and Specifications Unit has issued the revised CDOT Standard Plans <i>M-606-1 Midwest Guardrail System (MGS) Type 3 W-Beam 31 Inches</i> with 19 sheets and Project Special Detail <i>D-606-2 Midwest Guardrail System (MGS) Type 3 W-Beam 31 Inches without Blocks</i> with 18 sheets. They are effective for March 5, 2020.• All guardrails in these standards are now MASH compliant.

Introduction

Intended audience

This field guide (and the accompanying elearning course) are intended for CDOT and consultant construction engineers and inspectors.

You may find yourself working on the installation of a new guardrail, or the repair or replacement of an existing guardrail. Your responsibilities may be different depending on the type of project.

Type of project	Construction engineer	Inspector
Installation of new guardrail	Construction observation and compliance Notify design engineers of potential changes to the design	Inspect installation
Repair or replacement of existing guardrail	Help assess necessary repair or replacement Construction observation and compliance	Inspect installation

Regardless of your role, this field guide (and the accompanying elearning course) are intended to help you critically approach the installation, repair, or replacement of guardrail end anchorages to ensure that all elements are compatible and properly installed, and that the basic design is appropriate.

Where to get more information

For questions about guardrail standards and specifications, contact Joshua Keith at 303-757-9021.

For questions about the Guardrail Systems for Construction Engineers and Inspectors elearning course—and other Transportation Engineering Training Program (TETP) courses—contact Allison Wilson at Allison.Wilson@state.co.us or 303-757-9298.

CDOT MASH implementation

CDOT's guardrail standards are defined in:

- Standard Plan *M-606-1 Midwest Guardrail System (MGS) Type 3 W-Beam 31 Inches* (Placement, installation, materials, and specifications)
- Project Special Detail *D-606-2 Midwest Guardrail System (MGS) Type 3 W-Beam 31 Inches Without Blocks* (Placement, installation, materials, and specifications)
- Standard Plan *M-606-13 Guardrail Type 7 F Shape Barrier* (Details for F-shape concrete barrier)
- Standard Plan *M-606-14 Precast Type 7 Concrete Barrier* (Details of rebar, and pin and loop connections)
- Standard Plan *M-606-15 Guardrail Type 9 Single Slope Barrier* (Concrete barrier with single slope sides)

Check the **CDOT Design and Construction Project Support website**

(<https://www.codot.gov/business/designsupport>) to ensure that you are using the latest versions of these documents for your projects.

Major changes

The major changes included in CDOT's implementation of the MASH standards were listed in Project Support Memo 2015-04 *MASH-Tested 31-Inch Guardrail Implementation Policy and MASH Implementation Dates*:

- Raise the height of guardrail from 28 to 31 inches (from the pavement)
- Offset blocks are changed from 8 to 12 inches wide
- Change the guardrail splice locations from the guardrail posts to the center of the guardrail post spacing at the end of each of the W-beam panels
- Use an asymmetric versus symmetric transition to the concrete barriers and bridge rails

Implementation policies

Highlights of CDOT's MASH implementation policies include:

- Implementation dates
 - All of the MASH implementation dates have passed. You **must** use MASH 2016-compliant highway safety hardware for all new permanent installations and full replacements.
- Guardrail height
 - If the existing rail is not to be relocated or modified and the height of the rail is 26.5 inches or higher, it may remain in place until the next project.
 - If the existing rail height is less than 26.5 inches, then the entire rail must be raised or replaced (FHWA requirement).
 - If you are transitioning from an existing 28 inch guardrail to a new 31 inch MGS rail, see the detail in M-606-1, Sheet 4 of 19.

- Block width

- If the default 12-inch blocks cause an issue with the alignment, then 8-inch blocks or no blocks may be allowed. For the no blocks option, refer to Project Special Detail *D-606-2 Midwest Guardrail System (MGS) Type 3 W-Beam 31 Inches (Without Blocks)*.
 - Use of 8-inch blocks or no blocks requires a decision from CDOT's Standards and Specifications Unit.
 - The no blocks option also requires the use of steel posts.

Current end anchorages

Summary

These tables show the end anchorage systems currently allowed for new installations. Any end anchorages that are included in the Standard Plans for new installations may be repaired with the same system if they are damaged.

The allowed systems may change as manufacturers develop and test new systems, and as CDOT reviews and approves them.

Flared end anchorages			
System	Manufacturer	Type	Notes
MFLEAT	Road Systems, Inc.	Energy absorbing	MASH does not support the extreme flares allowed under earlier guidelines. The MFLEAT system is designed for a fixed 3-foot offset over the 39'-7" length.

Non-flared end anchorages			
System	Manufacturer	Type	Notes
MSKT	Road Systems, Inc.	Energy absorbing	For any of these systems, a straight flare of no more than 2 feet is allowed to avoid nuisance impacts.
MAX-Tension	Lindsay Transportation Solutions	Energy absorbing	
SoftStop	Trinity Highway Products, LLC	Energy absorbing	

Other		
System	Manufacturer	Notes
End Anchorage Type 3B	Generic	Buried in the backslope
End Anchorage Type 3D	Generic	Departure terminal
End Anchorage Type 3K	Generic	For low-speed use only

More information about each system is included on the following pages.



IMPORTANT

- **For proprietary end anchorages:** The end anchorage shall be installed conforming to the manufacturer's recommendations. The contractor shall provide a copy of the manufacturer's installation instructions and parts list to the engineer prior to the installation of the device.

You must **not** deviate from the manufacturer's instructions when installing end terminal systems and transitions. For example, you may **not** delete a post or change the allowed offset.

- **For non-proprietary end anchorages** (for example, Types 3B, 3D, and 3K): The end anchorage shall be installed according to the M-606-1 (or D-606-2) detail. There are no manufacturer's installation instructions for these systems.

You must **not** deviate from these standards when installing end terminal systems and transitions. For example, you may **not** delete a post from a 3G transition.

MFLEAT (Mash FLared Energy Absorbing Terminal)

Manufacturer	Road Systems, Inc. For current details of this system, see https://roadsystems.com/mash-mfleat/
Type	Energy absorbing
Installation	Flared
MASH compliant	Yes
How it works	This is an energy-absorbing terminal, which is also a flared terminal. The energy of a vehicle in a head-on impact is absorbed by the impact head being forced down the rails sequentially kinking them and extruding them on the traffic side of the guardrail.
Characteristics	<ul style="list-style-type: none">• Square impact head.• Enclosed feeder chute.• 39’-7” straight flared length.• Fixed 3-foot offset.• Posts 1-3 are steel-hinged post.• Beginning length of need (BLON) at post 4.



MSKT (Mash Sequential Kinking Terminal)

Manufacturer	Road Systems, Inc. For current details of this system, see https://roadsystems.com/mash-mskt/
Type	Energy absorbing
Installation	Non-flared
MASH compliant	Yes
How it works	This is an energy-absorbing system. The energy of a vehicle in a head-on impact is absorbed by the impact head being forced down the rail elements deforming them in short kinks which exit on the back side. This is a compression-based system. For higher angle hits on the nose, the vehicle breaks away the end and passes through and behind the guardrail. For side impacts beyond the BLON point (post 3), the vehicle should be redirected in front of the rail.
Characteristics	<ul style="list-style-type: none">• Square impact head.• Enclosed feeder chute (SKT engraved).• Post 1 tube top section, W 6 by 15 bottom section.• Post 2 steel-hinged post.• Posts 3–8 standard 6-foot long posts.



MAX-Tension

Manufacturer	Lindsay Transportation Solutions For current details of this system, see https://www.lindsay.com/usca/en/infrastructure/brands/barrier-systems/solutions/end-treatments/max-tension/
Type	Energy absorbing
Installation	Non-flared
MASH compliant	Yes
How it works	The MAX system uses tensioned cables, telescoping panels, and a cutting tooth to absorb kinetic energy and safely contain or redirect the striking vehicle. When impacted head-on, deceleration is controlled by friction in the tension cables and by cutting the downstream guardrail panels.
Characteristics	<ul style="list-style-type: none">• Rectangular impact faces does NOT work on rail.• All steel driven posts• Uses a slider mechanism at post 3 that gathers and retains the rails when hit head-on.• Anchor consists of posts 1 and 2 connected by tension struts and a soil plate below grade on post 2.



SoftStop

Manufacturer	Trinity Highway Products, LLC For current details of this system, see https://trinityhighway.com/product/softstop-system/
Type	Energy absorbing
Installation	Non-flared
MASH compliant	Yes
How it works	Using a proprietary head design, the system flattens and extrudes the W-beam guardrail upon end-on strikes, dissipating energy while guiding the flattened rail through the mouth at the bottom of the unit. The front anchorage is designed to allow the rail panels to remain anchored during end-on impacts. For higher angle hits on the nose, the vehicle pushes over the guardrail and passes through and behind the guardrail.
Characteristics	<ul style="list-style-type: none"> • Narrow, rectangular impact head and chute. • Anchor post in front of the impact head (post 0). • Post 1: 4'-9½" Steel Yielding Terminal Post (SYTP). • Post 2: 6' SYTP. • Posts 3-8: standard 6' long posts. • TL-3 at 50'-9½" long. • BLON at 16'-6". • 31" only, adaption needed for Type 28" connection. • End-rail element is split, passes through the impact head, and is connected (with two bolts) to post 0 (the foundation post).



End Anchorage Type 3B

Manufacturer	Generic
Type	End anchorage
Installation	Flared
MASH compliant	N/A
General information	Buried in the backslope

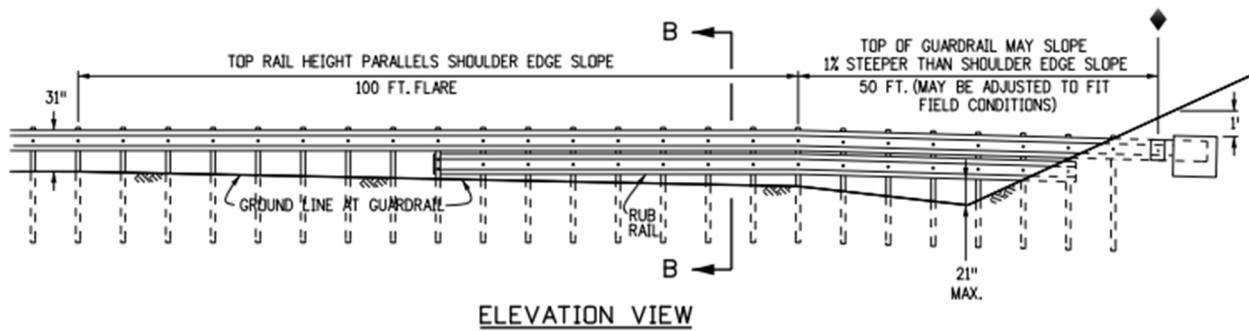
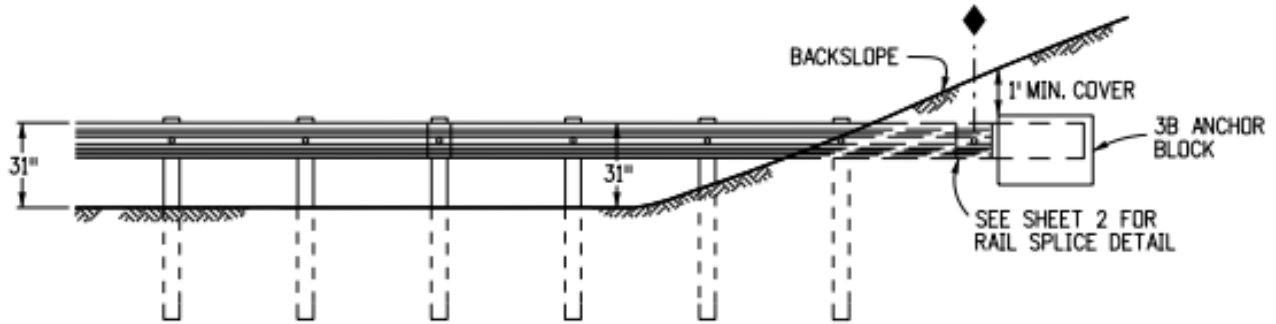

Source: FHWA Roadside Safety Systems Design, Inspection and Maintenance Training

End Anchorage Type 3D

Manufacturer	Generic
Type	Departure terminal
Installation	Non-flared
MASH compliant	N/A
General information	Departure terminal

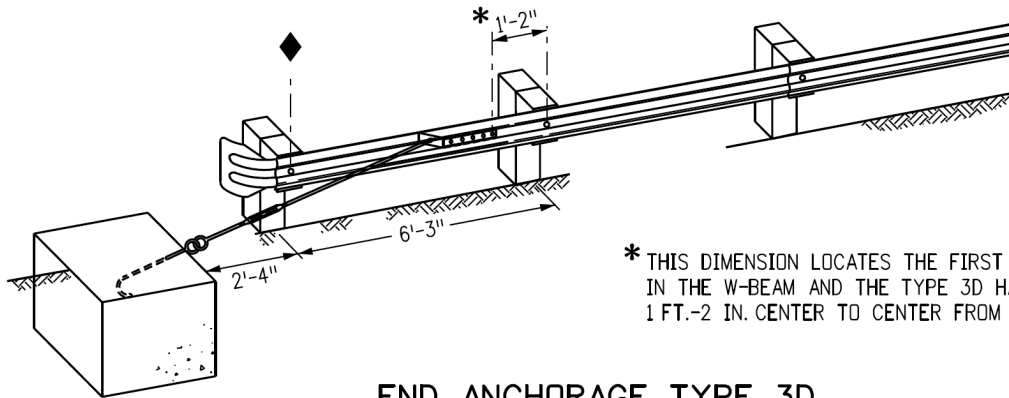

**END ANCHORAGE TYPE 3D
DEPARTURE TERMINAL**



End Anchorage Type 3K

For speeds < 45 MPH

Manufacturer	Generic
Type	End anchorage
Installation	Non-flared
MASH compliant	N/A
General information	The low-speed end anchorage Type 3K shall be used only on driveways and low-speed service roads. When an approved crash-tested end treatment is required, use the end anchorage (flared or non-flared) with 37 foot-6 inch length.

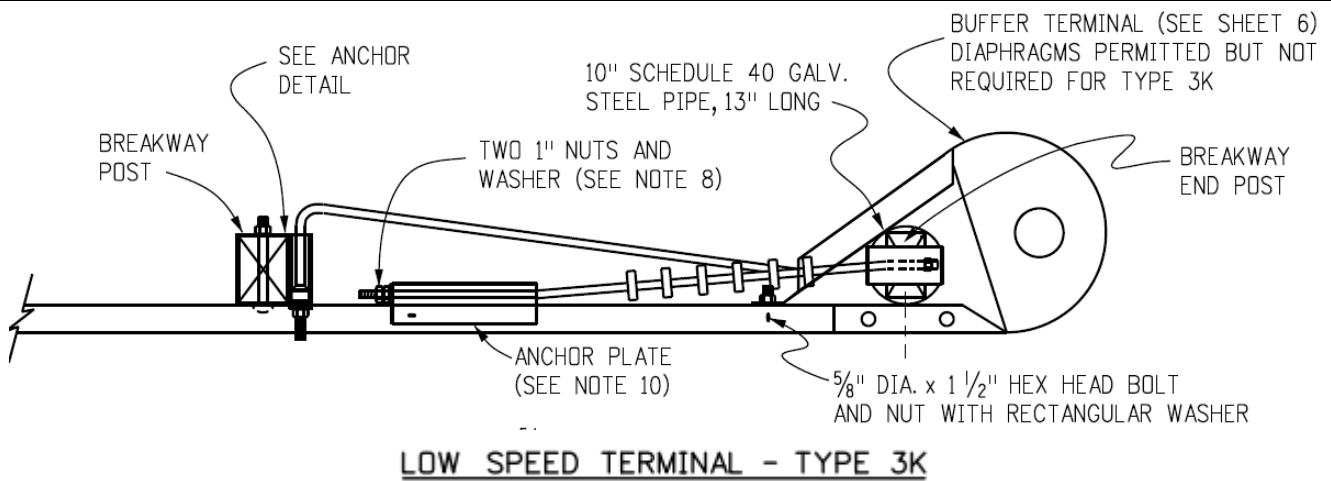

Current transitions

Summary

This table shows the transitions currently allowed for new installations. Any transitions that are included in the Standard Plans for new installations may be repaired with the same system if they are damaged.

The allowed transitions may change as manufacturers develop and test new systems, and as CDOT reviews and approves them.

Transitions		
System	Manufacturer	Notes
Transition Type 3G		Approach transition
Transition Type 3H		Departure transition
Transition Type 3J		Transition for intersecting roadways

More information about each transition is included on the following pages.

Transition Type 3G

Type	Approach transition
Installation	Non-flared
MASH compliant	Yes
General information	Transition Type 3G is for use at both ends of bridges on two-way highways and at the approach end of bridges on one-way highways. It is also used to connect to Type 7, Type 8, and Type 10 bridge rail.

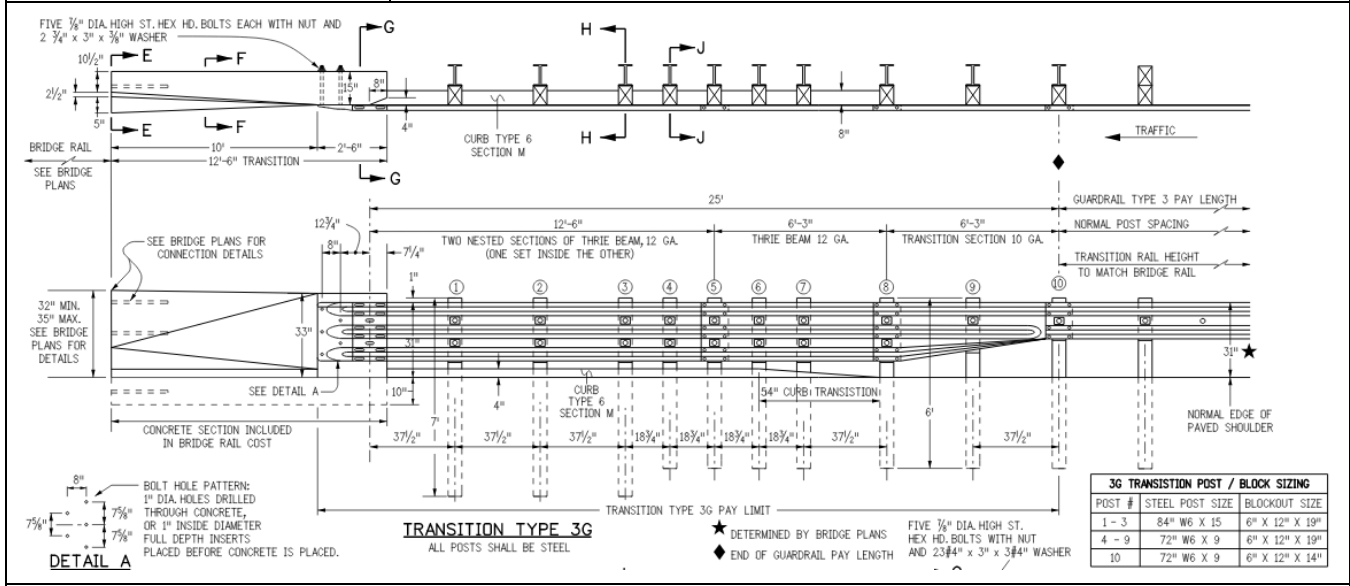

Transition Type 3H

Type	Departure transition
Installation	
MASH compliant	Yes
General information	Transition Type 3H is for use at the trailing end of bridges on one-way highways. It is also used to connect to Type 8 and Type 10 bridge rail.

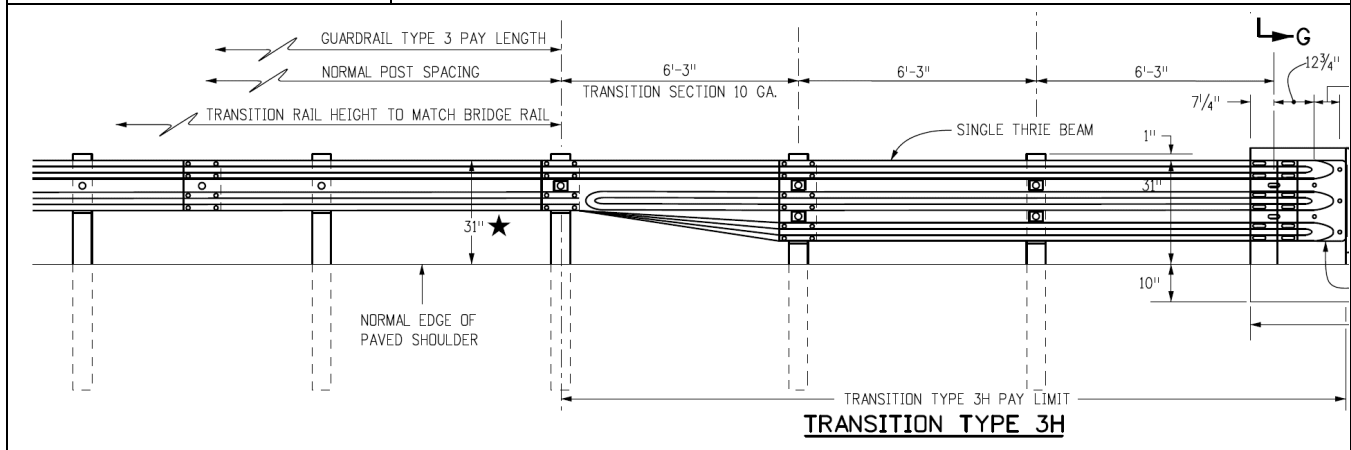

Transition Type 3J

Type	Transition for intersecting roadways
Installation	
MASH compliant	N/A
General information	Transition Type 3J may be used to shield hazards at the intersection of two roadways. Typical applications include canal service roads at bridge ends, interruptions in guardrail runs by intersecting roadway, etc.

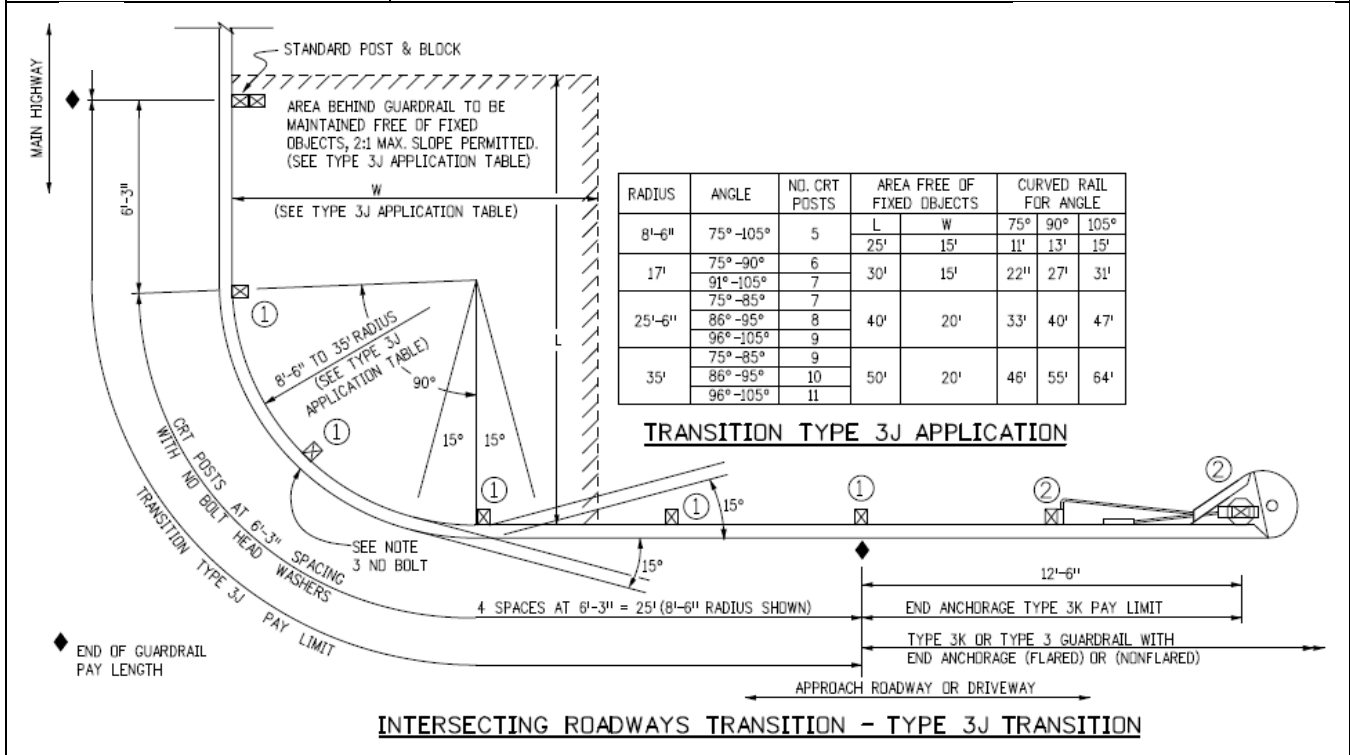

Current median terminals

Summary

This table shows the median terminals currently allowed for new installations. Any median terminals that are included in the Standard Plans for new installations may be repaired with the same system if they are damaged.

The allowed median terminals may change as manufacturers develop and test new systems, and as CDOT reviews and approves them.

Median terminals		
System	Manufacturer	Notes
MAX-Tension Median End Treatment	Lindsay Transportation Solutions	Is only approved for median applications

More information about each median terminal is included on the following pages.

MAX-Tension Median

Manufacturer	Lindsay Transportation Solutions For current details of this system, see https://www.lindsay.com/usca/en/infrastructure/brands/barrier-systems/solutions/end-treatments/max-tension/
Type	Energy absorbing
Installation	Non-flared, median
MASH compliant	Yes
How it works	The system utilizes a tension-based design along with an energy absorbing coupler that features a cutting tooth design.
General information	<ul style="list-style-type: none">• When impacted head-on, deceleration is controlled by friction developed in the tension cables and by cutting the downstream guardrail panels.• When a side impact occurs, tension cables can help safely redirect a motorist away from the hazard.



End treatments that are no longer allowed

Summary

These tables show the end anchorages and terminals, transitions, and median terminals that are no longer allowed for new installations.

End anchorages and terminals			
System	Manufacturer	Reason	Action
X-Lite	Lindsay Transportation Solutions	Does not meet current standards	Must be replaced with a system that is allowed per the Standard Plans.
Turned-down rail	Generic	Does not meet current standards	
3E/Breakaway Cable Terminal (BCT)	Generic	Does not meet current standards	Must be replaced with a system that is allowed per the Standard Plans if damaged or within the limits of a construction or maintenance project.
ET-2000	Trinity Highway Products, LLC	No longer being manufactured	
ET Plus	Trinity Highway Products, LLC	Does not meet current standards	
SKT	Road Systems, Inc.	Does not meet current standards	May be replaced if lightly damaged or left in place unless the construction or maintenance project includes the guardrails.
SRT-31	Trinity Highway Products, LLC	Does not meet current standards	
FLEAT 350	Road Systems, Inc.	Does not meet current standards	

Transitions			
System	Manufacturer	Reason	Action
Type 3L	Generic	Does not meet current standards	Not allowed for projects advertised after December 31, 2018.

Median terminals			
System	Manufacturer	Reason	Action
Brakemaster 350	Energy Absorption Systems, Inc.	No longer manufactured	Not allowed for projects advertised after December 31, 2018. May be replaced if lightly damaged or left in place unless the construction or maintenance project includes the guardrails.
CAT 350	Trinity Highway Products, LLC	Does not meet current standards	
FLEAT-MT	Road Systems, Inc.	Does not meet current standards	

More information about each system is included on the following pages.

End anchorages and terminals

X-Lite

Manufacturer	Lindsay Transportation Solutions
Type	Energy absorbing
Installation	Flared or non-flared
MASH compliant	No
How it works	The X-Lite Terminal uses a telescoping, non-extruding design.
IMPORTANT	Does not meet current standards Must be replaced with a system allowed per the Standard Plans.



Turned-down rail

Manufacturer	Generic
Type	Non-energy absorbing
Installation	Flared
MASH compliant	No
How it works	The concept of these terminals was to anchor the approach end, preventing it from penetrating the passenger compartment of a vehicle.
IMPORTANT	Does not meet current standards. If damaged or within the limits of a construction or maintenance project, replace with a system allowed per the Standard Plans.



3E/Breakaway Cable Terminal (BCT)

Manufacturer	Generic
Type	Non-energy absorbing
Installation	Flared
MASH compliant	No
How it works	A steel cable connecting the bottom of the first post to the guardrail beam provided an anchor to the barrier.
IMPORTANT	Does not meet current standards. If damaged or within the limits of a construction or maintenance project, replace with a system allowed per the Standard Plans.



ET-2000 (Guardrail Extruder Terminal)

Manufacturer	Trinity Highway Products, LLC
Type	Energy absorbing
Installation	Non-flared
MASH compliant	No
How it works	Rail section is extruded or squeezed, causing it to be flattened away from traffic.
IMPORTANT	No longer being manufactured. If damaged or within the limits of a construction or maintenance project, replace with a system allowed per the Standard Plans.



ET Plus (Guardrail Extruder Terminal)

Manufacturer	Trinity Highway Products, LLC
Type	Energy absorbing
Installation	Non-flared
MASH compliant	No
How it works	Rail section is extruded or squeezed, causing it to be flattened away from traffic.
IMPORTANT	Does not meet current standards. If damaged or within the limits of a construction or maintenance project, replace with a system allowed per the Standard Plans.



SKT (Sequential Kinking Terminal)

Manufacturer	Road Systems, Inc.
Type	Energy absorbing
Installation	Non-flared
MASH compliant	No
How it works	Rail section is sequentially kinked and exits on back side.
IMPORTANT	Does not meet current standards. May be replaced if lightly damaged or left in place unless the construction or maintenance project includes the guardrails.



SRT-31 (Slotted Rail Terminal)

Manufacturer	Trinity Highway Products, LLC
Type	Non-energy absorbing
Installation	Flared
MASH compliant	No
How it works	<p>The SRT-31 is a gating, flared end terminal and is supplied as a 6-post system.</p> <p>The SRT-31 uses horizontal slots in the W-beam itself that effectively divide the beam into four sections. Upon impact, the beam bends out of the way in a controlled manner, absorbing energy.</p> <p>The system uses an SRT buffer, not an impact head.</p>
IMPORTANT	<p>Does not meet current standards.</p> <p>May be replaced if lightly damaged or left in place unless the construction or maintenance project includes the guardrails.</p>

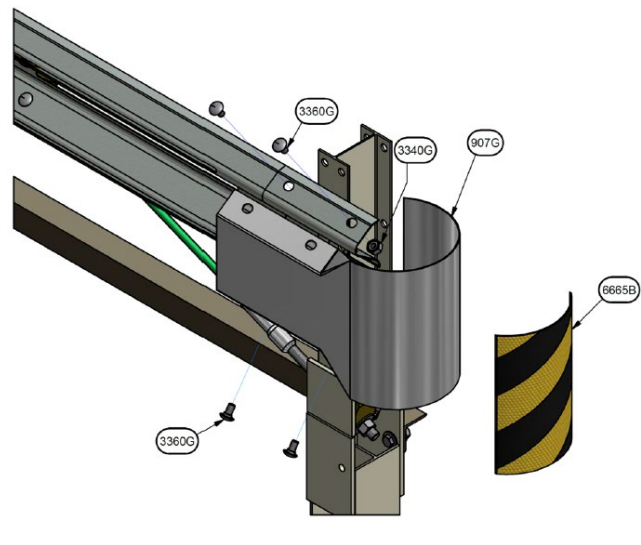

FLEAT 350 (FLared Energy Absorbing Terminal)

Manufacturer	Road Systems, Inc.
Type	Energy absorbing
Installation	Flared
MASH compliant	No
How it works	The rail section is sequentially kinked and exits on traffic side.
IMPORTANT	Does not meet current standards. May be replaced if lightly damaged or left in place unless the construction or maintenance project includes the guardrails.

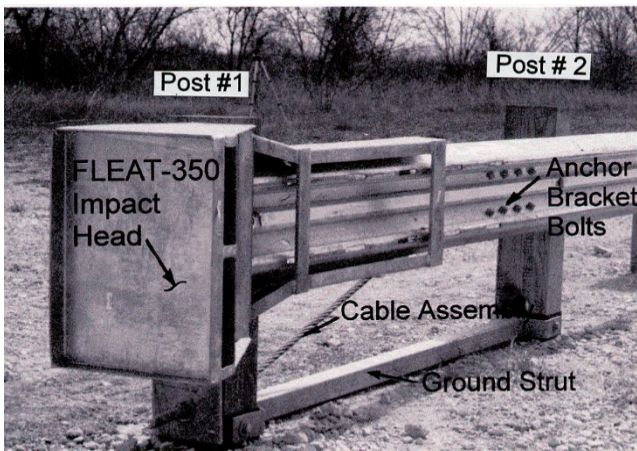

Transitions

Transition Type 3L

Type	Approach and departure transition
Installation	Non-flared
MASH compliant	N/A
How it works	
General information	May be used as a transition to the existing CBC, headwall, or curb. For a transition from a roadway Type 3 W-beam to a bridge rail Type 3 with backing tubes, the Transition Type 3L shall be used.
IMPORTANT	Does not meet current standards. Not allowed for projects advertised after December 31, 2018.

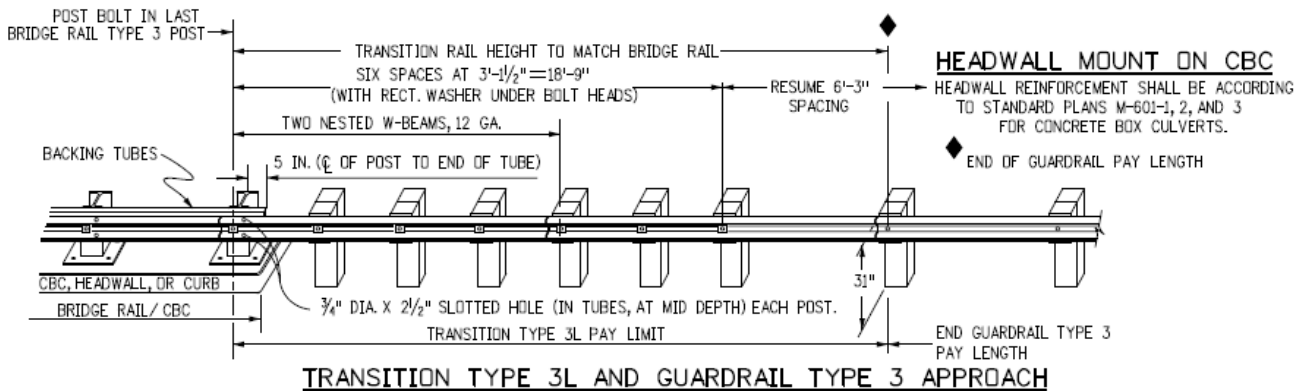

Source: Google Street View

(https://www.google.com/maps/@40.581368,-104.339745,3a,57.4y,6.28h,70.55t/data=!3m6!1e1!3m4!1sowW5Nsjob7_ZEzL7vkzCqA!2e0!7i13312!8i6656)

Median terminals

Brakemaster 350 Crash Cushion System

Manufacturer	Energy Absorption Systems, Inc.
Type	Energy-absorbing, gating, redirective crash cushion system
Installation	Median or as a crash cushion
MASH compliant	No
How it works	During head-on impacts, the system telescopes rearward, using friction technology to decelerate the vehicle.
General information	The Brakemaster 350 is the quick and easy solution for shielding dangerous guardrail ends at wide median and roadside sites with adequate clear zones. It provides superior bidirectional protection and does not require a concrete anchor or pad, making it fast and easy to install.
IMPORTANT	No longer manufactured. Not allowed for projects advertised after December 31, 2018. May be replaced if lightly damaged or left in place unless the construction or maintenance project includes the transition.



CAT 350 (Crash Cushion Attenuating Terminal)

Manufacturer	Trinity Highway Products, LLC
Type	Energy absorbing
Installation	Median or on the shoulder
MASH compliant	No
How it works	The slotted W-beam telescopes backward during impact; the shearing of the steel rail between the slots dissipates the kinetic energy.
General information	<p>The CAT 350 is an energy-absorbing attenuator available for use where single or double-sided (8" or 12") W-beam are in the median or on the shoulder.</p> <ul style="list-style-type: none"> • CAT 350 and CAT tail can be used as a W-beam barrier end treatment, or as a crash cushion either in the median or on the shoulder. • Various post and post/sleeve options are available. • Long-lasting, durable galvanized components. • CAT-350 requires transition for rigid barrier or fixed objects.
IMPORTANT	<p>Does not meet current standards.</p> <p>Not allowed for projects advertised after December 31, 2018.</p> <p>May be replaced if lightly damaged or left in place unless the construction or maintenance project includes the transition.</p>



FLEAT-MT

Manufacturer	Road Systems, Inc.
Type	Energy absorbing
Installation	Flared
MASH compliant	No
How it works	The front single-sided section of the FLEAT-MT is similar to the roadside FLEAT and functions the same way. Depending on the severity of the impact, the vehicle may be stopped before reaching the second impact head at post 4. If the end-on impact is severe enough, the vehicle will activate the second impact head. This impact head will then begin to slide down the rail sequentially kinking the backside rail.
General information	<p>The FLEAT-MT is a Median Terminal for use in wide medians. The components of the original roadside FLEAT are combined with a couple of small additional components to create the FLEAT-MT.</p> <ul style="list-style-type: none"> • Attaches directly to median double-sided W-beam rail • Fast and easy installation and repair • 37'-6" long for Test Level 3 design speed • Can be used with wood or steel breakaway posts
IMPORTANT	<p>Does not meet current standards.</p> <p>Not allowed for projects advertised after December 31, 2018.</p> <p>May be replaced if lightly damaged or left in place unless the construction or maintenance project includes the transition.</p>
	

Guardrail design review

This section summarizes the *Guardrail system design* and *Guardrail terminal systems* modules from the Guardrail Systems for Construction Engineers and Inspectors elearning course. For more information, please see the elearning course or the identified source documents.

Guardrail system design

Purpose of a guardrail

According to the Federal Highway Administration’s “Guardrail 101” website, “A guardrail is, first and foremost, a safety barrier intended to shield a motorist who has left the roadway.”

Guardrails should be installed “when the consequences of striking a guardrail would be less severe than striking the other objects next to the roadway” or running off the roadway into a hazard or onto a severe slope or drop-off. Guardrails “can make roads safer and lessen the severity of crashes.” They “can operate to deflect a vehicle back to the roadway, slow the vehicle down to a complete stop, or, in certain circumstances, slow the vehicle down and then let it proceed past the guardrail.”

“This is not to say that guardrails can completely protect against the countless situations drivers may find themselves in. The size and speed of the vehicle can affect guardrail performance.”

Functional components of a guardrail system

Guardrails work as a system with two key functional components:

- The **guardrail face** is the length of the guardrail extending from the end anchorage alongside the road. Its function is always to safely redirect the vehicle back onto the roadway.
- The **end anchorage** (which may also be referred to as the end terminal or the end treatment) is the starting point of the guardrail. It functions in two ways:

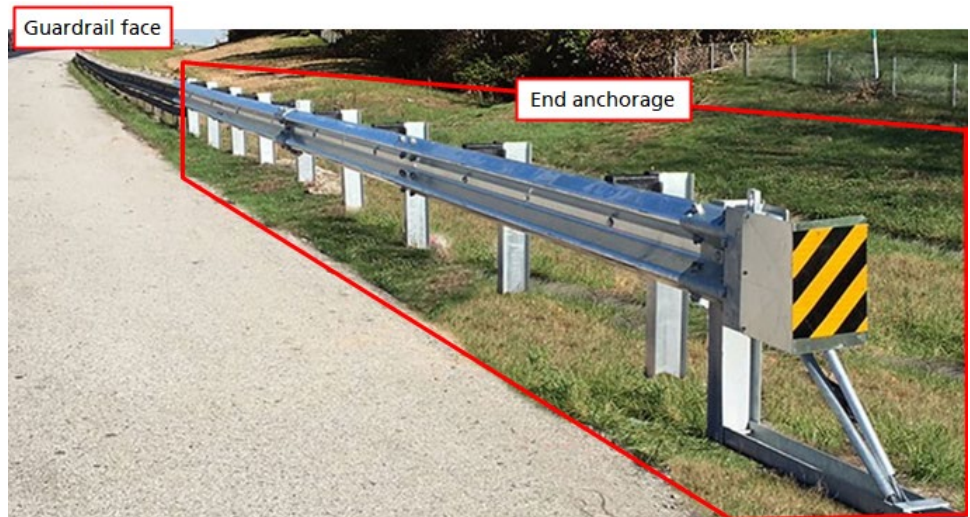

- When hit head-on, the impact head (or end cap) slides down the guardrail flattening or compressing the guardrail. This redirects the guardrail away from the vehicle until the vehicle's impact energy is dissipated and the vehicle has decelerated to a stop.
- When hit at an angle, the impact head may partially extrude the guardrail and then “gate” out of the way. This allows the vehicle to pass behind the guardrail.

Types of guardrail installations

There are two ways to design and install the guardrail face: tangent (also referred to as non-flared) and flared. End anchorages can also be tangent or flared.

- A roadside barrier, or an end anchorage, is considered tangent when it is parallel to the edge of the traveled way.
- A roadside barrier, or an end anchorage, is considered flared when it is NOT parallel to the edge of the traveled way.

This drawing shows an example of a guardrail used to protect vehicles from hitting an obstruction next to the roadway.

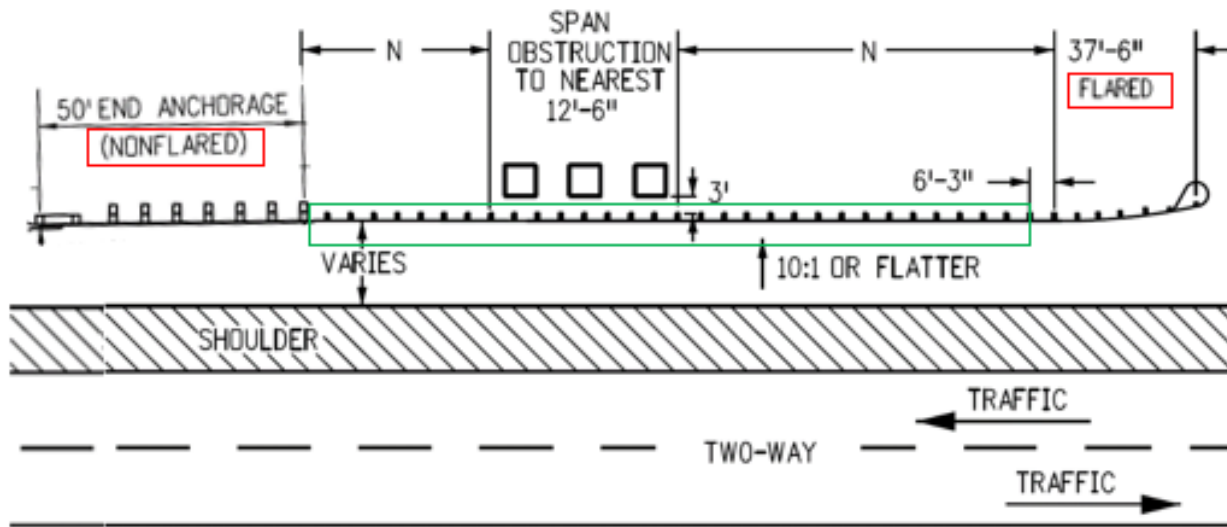

This drawing shows a tangent guardrail installation where “N” = the length required to protect the obstruction as determined by the length of need (LON) computation (min. 12'-6" where conditions allow).

When the guardrail is tangent, the end anchorage can be tangent or flared.

In this example, on the right, the upstream end anchorage is flared. On the left, the downstream end anchorage is tangent.

Note that a tangent end treatment can have an offset to prevent nuisance hits, but please consult the manufacturer’s recommendations for the appropriate offset distance.

This drawing shows an example of the guardrails at the end of a narrow bridge.

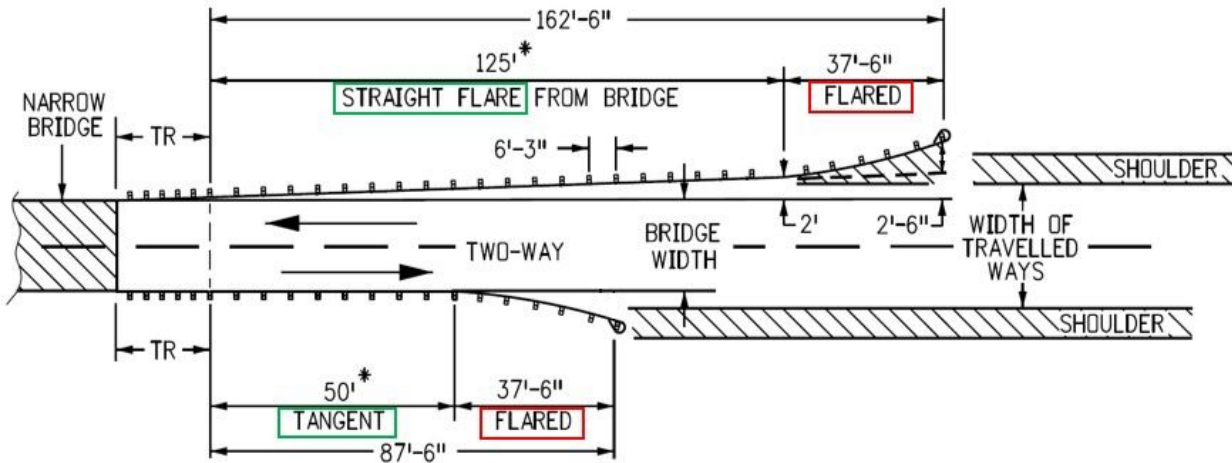

This drawing shows both a flared guardrail (on the top) and a tangent guardrail (on the bottom). Both end anchorages are flared.

When the guardrail is tangent, the end anchorage can be tangent or flared. But when the guardrail is flared, the end anchorage is almost always flared.

Length of need

The length of need is defined as the length of barrier needed in advance (upstream) of a fixed object hazard or a non-traversable terrain feature to prevent a vehicle that has left the roadway from reaching the shielded feature.

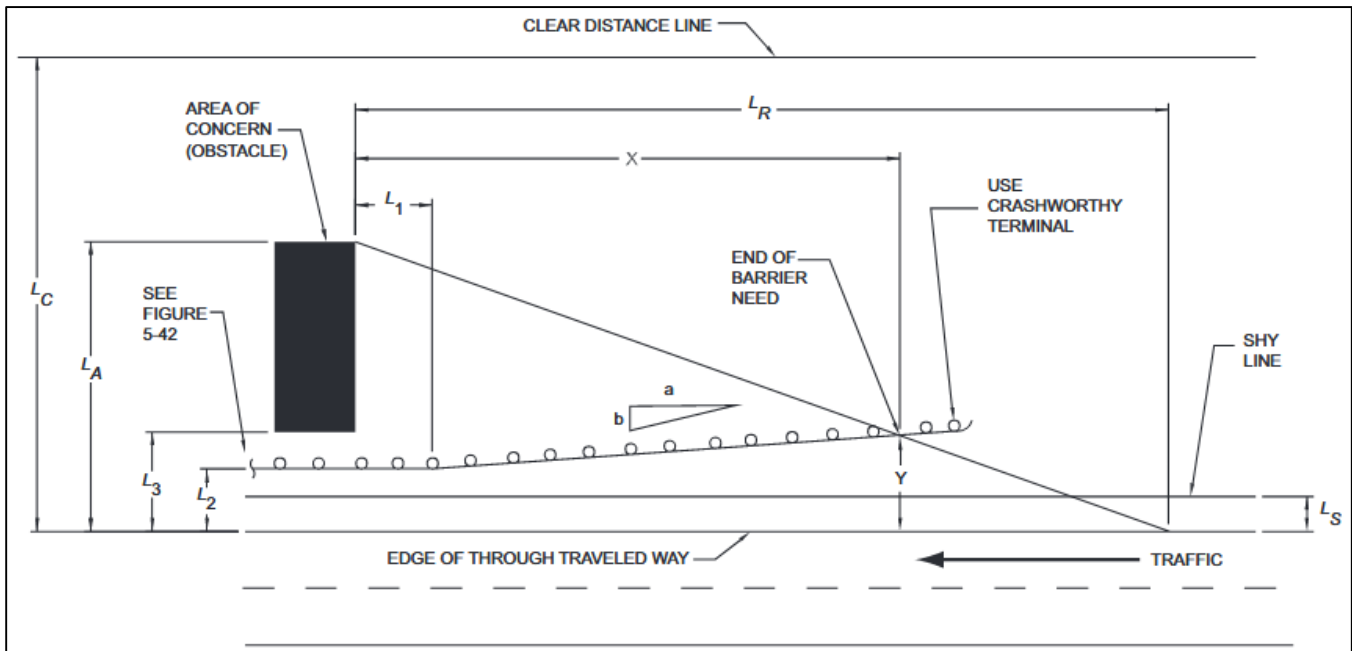

Source: July 2015 Errata for the AASHTO Roadside Design Guide, 4th Edition.

The length of need can be determined by selecting the appropriate variables and using the formula shown below.

$$X = \frac{L_A + (b/a) (L_1) - L_2}{(b/a) + (L_A/L_R)}$$

X = Distance from the obstruction to end of barrier need.

Y = Distance from edge of through traveled way to the beginning of the length-of-need.

L_A = Distance from edge of through traveled way to lateral extent of obstruction.

L₁ = Tangent length of barrier upstream from obstruction.

L₂ = Distance from edge of through traveled way to barrier.

L₃ = Distance from edge of through traveled way to obstruction.

L_C = Distance from edge of through traveled way to outside edge of the clear zone.

L_R = The theoretical Runout Length needed for a vehicle leaving the roadway to stop.

a : b = Flare Rate.

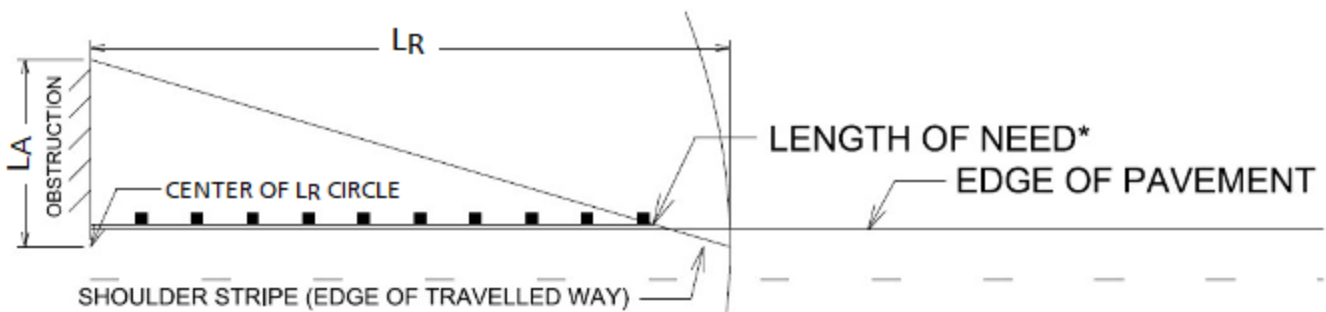

- Start with the obstruction, whatever it is.
- L_A is the distance from the edge of the traveled way to the far side of the obstruction.
- Draw a circle, centered where the edge of the traveled way and the obstruction come together, with radius L_R, where L_R is the runout length from the Suggested Runout Lengths for Barrier Design tables in the Roadside Design Guide.
- Draw a line from the far side of the obstruction L_A, to the point where the circle meets the edge of the traveled way.
- The point where that line intersects the edge of pavement will give you a very conservative length of need. In most cases, there is nothing wrong with erring on the side of extra guardrail length. Then attach the end terminal.

Note that you should save these calculations as part of the project notes.

Guardrail terminal systems

According to the AASHTO Roadside Design Guide, “a terminal is considered essential if the end of a barrier is located within the clear zone or in an area where it is likely to be struck by an errant motorist.”

A barrier terminal must serve two functions:

- It must “be crashworthy when impacted end on.”
- And it must “provide anchorage for downstream hits.”

Primary end terminal designs

The three primary W-beam guardrail end terminal designs in use at present are:

Buried-in-backslope

design terminates a W-beam guardrail installation by burying the end in the backslope. This is an ideal option if conditions permit.



Source: FHWA Roadside Safety Systems Design, Inspection and Maintenance Training

<http://www.dot.ca.gov/hq/LocalPrograms/HSIP/training.htm>

The **non-energy-absorbing** design does **NOT** dissipate a significant amount of energy in a head-on crash. It is a gating system that allows the vehicle to traverse the area behind and parallel to the guardrail. Therefore, it should be used only when there is sufficient run-out.

Vehicle Trajectories by Terminal Type

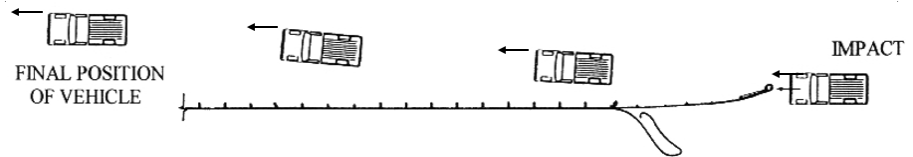

Non-Energy Absorbing Terminal
Controlled Buckling Terminal
(vehicle may travel hundreds of feet before stopping)

The **energy-absorbing** design **DOES** dissipate a significant amount of kinetic energy in a head-on crash. For barrier installations fewer than 150 feet in advance of any shielded object, you must use an energy-absorbing design.

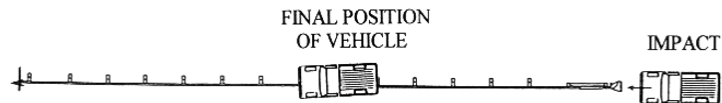

Energy Absorbing Terminal
(vehicle is brought to a controlled stop in a short distance)

These drawings show the relative trajectories of a vehicle impacting non-energy-absorbing and energy-absorbing terminals head-on at high speed (62 mph).

Source: FHWA Selection, Installation and Maintenance of W-Beam Guardrail End Terminals

https://safety.fhwa.dot.gov/roadway_dept/countermeasures/reduce_crash_severity/policy_memo/memo052615/memo052615_attachment.cfm

Terminal selection

According to the AASHTO Roadside Design Guide, the decision about which design to use “should be based on the likelihood of a near end-on impact and the nature of the recovery area immediately behind and beyond the terminal.”

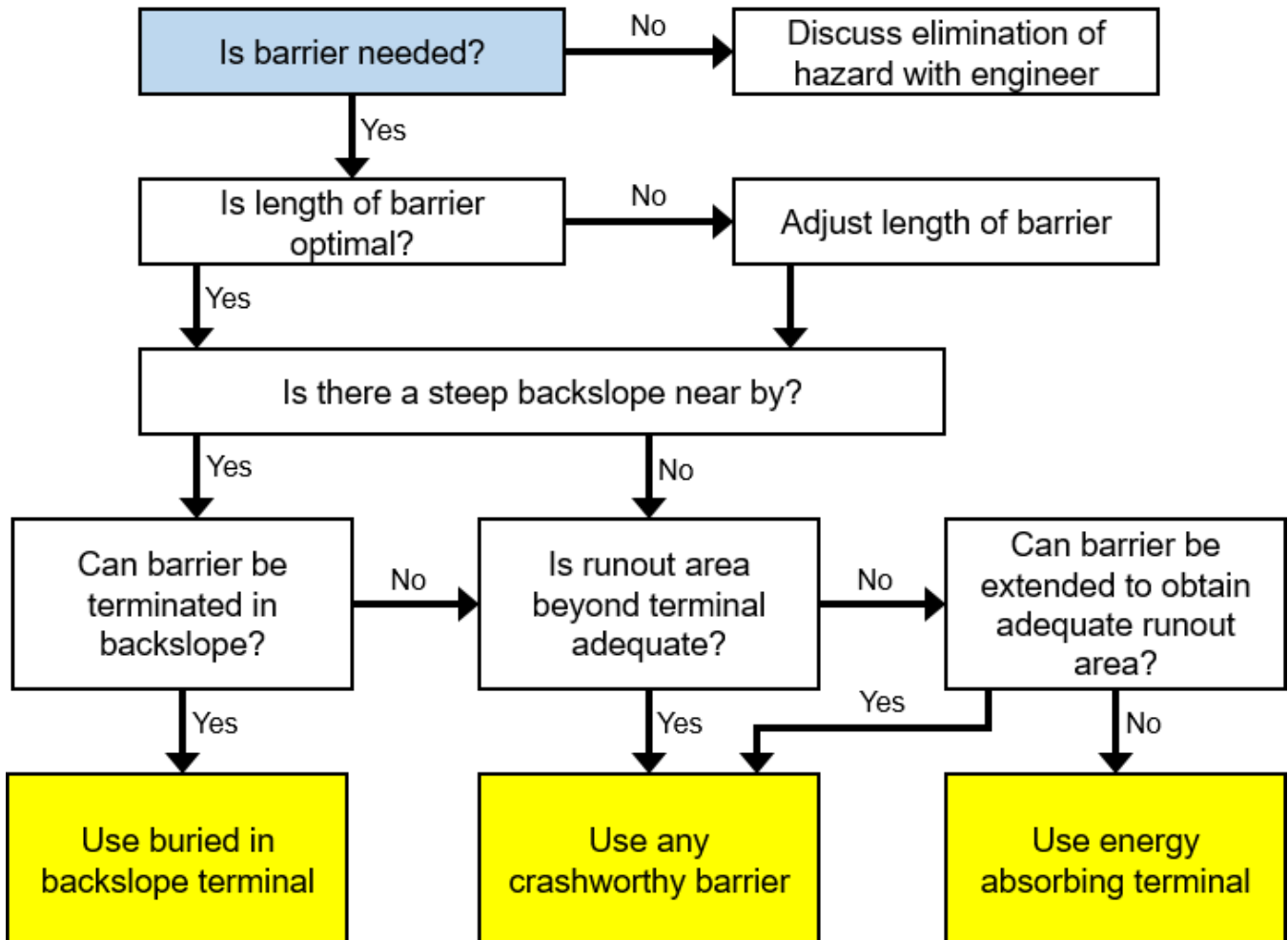

Adapted from FHWA Selection, Installation and Maintenance of W-Beam Guardrail End Terminals

https://safety.fhwa.dot.gov/roadway_dept/countermeasures/reduce_crash_severity/policy_memo/memo052615/memo052615_attachment.cfm

Resources

Glossary

Term	Definition
AASHTO	American Association of State Highway and Transportation Officials
Clear zone	<p>“A Clear Zone is an unobstructed, traversable roadside area that allows a driver to stop safely, or regain control of a vehicle that has left the roadway. The width of the clear zone should be based on risk (also called exposure). Key factors in assessing risk include traffic volumes, speeds, and slopes. Clear roadsides consider both fixed objects and terrain that may cause vehicles to rollover.”</p> <p>Source: https://safety.fhwa.dot.gov/roadway_dept/countermeasures/safe_recovery/clear_zones/</p>
CRP	Cable Release Post
CRT	Controlled Releasing Terminal post
End treatment	The starting or end point of the guardrail. End treatments include and may also be referred to as end terminals, end anchorages, and crash cushions.
FHWA	Federal Highway Administration
Flared	<p>A roadside barrier or an end treatment is considered flared when it is not parallel to the edge of the traveled way.</p> <p>When the guardrail is flared, the end treatment is almost always flared.</p>
FLEAT	FLared Energy Absorbing Terminal
HBA	Steel Hinged Breakaway (HBA) post
HMA	Hot Mix Asphalt
LON (Length of Need)	The length of need is defined as the length of barrier needed in advance (upstream) of a fixed object hazard or a non-traversable terrain feature to prevent a vehicle that has left the roadway from reaching the shielded feature.
MASH	Manual for Assessing Safety Hardware
MGS	Midwest Guardrail System
MUTCD	Manual on Uniform Traffic Control Devices
NCHRP	National Cooperative Highway Research Program

Non-flared (or tangent)	<p>A roadside barrier or an end anchorage is considered non-flared (or tangent) when it is parallel to the edge of the traveled way.</p> <p>When the guardrail is tangent, the end treatment can be flared or non-flared.</p> <p>Note that a tangent end treatment can have an offset to prevent nuisance hits, but please consult the manufacturer's recommendations for the appropriate offset distance.</p>
Shy line	<p>The offset distance beyond which a roadside object will not be perceived as an obstacle and result in a motorist's reducing speed or changing vehicle position on the roadway.</p>
SKT	Sequential Kinking Terminal
SRT	Slotted Rail Terminal
SYTP	Steel Yielding Terminal Post
TRB	Transportation Research Board

Web links

CDOT
CDOT Design and Construction Support (for M&S Standard Plans) https://www.codot.gov/business/designsupport
CDOT Project Support Memo 2015-4 “Mash Tested 31-Inch Guardrail Implementation and Mash Implementation Dates” https://codot.gov/business/designsupport/bulletins_manuals/dps-memos/psm-2015-04/view
CDOT Frequently Asked Questions about Guardrails, Crash Cushions, and End Treatments https://codot.gov/business/designsupport/standard-plans/guardrail-faq/view
CDOT Construction Specifications https://codot.gov/business/designsupport/cdot-construction-specifications
CDOT Approved Products List https://www.codot.gov/business/apl
AASHTO
AASHTO Roadside Design Guide, 4th Edition Errata https://downloads.transportation.org/RSDG-4-Errata.pdf
FHWA
FHWA Guardrail 101 https://safety.fhwa.dot.gov/roadway_dept/countermeasures/reduce_crash_severity/guardrail101.cfm
FHWA Guardrail Resources https://safety.fhwa.dot.gov/roadway_dept/countermeasures/reduce_crash_severity/guardrail_ispe.cfm
FHWA Selection, Installation and Maintenance of W-Beam Guardrail End Terminals (website) – includes terminal selection decision tree https://safety.fhwa.dot.gov/roadway_dept/countermeasures/reduce_crash_severity/policy_memo/memo052615/memo052615_attachment.cfm
FHWA Selection, Installation and Maintenance of W-Beam Guardrail End Terminals (PDF) – includes terminal selection decision tree https://safety.fhwa.dot.gov/roadway_dept/countermeasures/reduce_crash_severity/policy_memo/memo052615/memo052615.pdf



Manufacturers
Road Systems, Inc. (MFLEAT, MSKT) https://roadsystems.com/
Lindsay Transportation Solutions (MAX-Tension, MAX-Tension Median) https://www.lindsay.com/usca/en/infrastructure/brands/barrier-systems/
Trinity Highway Products, LLC (SoftStop) https://trinityhighway.com/