

Report No. CDOT-DTD-R-94-9

Influence of Compaction Temperature and Anti-Stripping Treatment on the Results from the Hamburg Wheel- Tracking Device

Timothy Aschenbrener and Nava Far
Colorado Department of Transportation
4340 East Louisiana Avenue
Denver, Colorado 80222

Final Report
July 15, 1994

Prepared in cooperation with the
U.S. Department of Transportation
Federal Highway Administration

The contents of this report reflect the views of authors who are responsible for the facts and the accuracy of the data presented herein. The contents do not necessarily reflect the official views of the Colorado Department of Transportation or the Federal Highway Administration. This report does not constitute a standard, specification, or regulation.

Acknowledgements

The authors would like to express their gratitude to the many people who assisted in performing this study. Dave Price (CDOT-Research) assisted with performing testing on all the samples.

The CDOT Research Panel provided many excellent comments and suggestions for the study; it included Byron Lord and Kevin Stuart (FHWA-Turner Fairbank Highway Research Center), Doyt Bolling and Richard Zamora (FHWA-Region 8), Jerry Cloud (FHWA-Colorado Division), Steve Horton and Bob LaForce (CDOT-Staff Materials), Ken Wood (CDOT-Region 4 Materials), and Donna Harmelink (CDOT-Research).

Special thanks to the panel of Colorado Asphalt paving experts who provided numerous ideas and suggestions which made the study more informational: Bud Brakey (BCE), Jim Fife (Western Colorado Testing), Joe Proctor (Morton International), Scott Shuler (CAPA), and Eric West (Western Mobile).

Technical Report Documentation Page

1. Report No. CDOT-DTD-R-94-9		2. Government Accession No.		3. Recipient's Catalog No.	
4. Title and Subtitle Influence of Compaction Temperature and Anti-Stripping Treatment on the Results from the Hamburg Wheel-Tracking Device				5. Report Date July 15, 1994	
				6. Performing Organization Code	
7. Author(s) Tim Aschenbrener and Nava Far				8. Performing Organization Rpt.No. CDOT-DTD-R-94-9	
9. Performing Organization Name and Address Colorado Department of Transportation 4201 E. Arakansas Ave. Denver, Colorado 80222				10. Work Unit No. (TRAIS)	
				11. Contract or Grant No.	
12. Sponsoring Agency Name and Address Colorado Department of Transportation 4201 E. Arkansas Ave. Denver, Colorado 80222				13. Type of Rpt. and Period Covered Final Report	
				14. Sponsoring Agency Code	
15. Supplementary Notes Prepared in Cooperation with the U.S. Department of Transportation Federal Highway Administration					
16. Abstract <p>The Hamburg wheel-tracking device can be used to predict the moisture susceptibility of a hot mix asphalt pavement. This report shows how the test results are influenced by compaction temperature and anti-stripping treatment. The higher the compaction temperature, the better the results in the Hamburg wheel-tracking device. The use of hydrated lime and liquid anti-stripping additives improved the results in the Hamburg wheel-tracking device over HMAs that were not treated. Hydrated lime dramatically improved the HMAs that were not treated. Liquid anti-stripping additives improved some of the HMAs dramatically while other HMAs were only improved slightly. These variables are important to control in the laboratory environment to ensure repeatability of the test. Additionally, these variables are also considered important to the moisture resistance of a pavement in the field.</p>					
17. Key Words Hamburg Wheel-Tracking Device			18. Distribution Statement No Restrictions: This report is available to the public through the National Technical Info. Service. Springfield, VA 22161		
19. Security Classif. (report) Unclassified		20. Security Classif. (page) Unclassified		21. No. of Pages 52	22. Price

Table of Contents

1.0 INTRODUCTION	1
2.0 HAMBURG WHEEL-TRACKING DEVICE	2
2.1 Equipment and Procedures	2
2.1.1 Hamburg Wheel-Tracking Device	2
2.1.2 Linear Kneading Compactor	2
2.2 Results and Specifications	5
3.0 MATERIAL DESCRIPTIONS	7
3.1 Asphalt Cements	7
3.2 Aggregates	7
3.3 Hot Mix Asphalt	8
4.0 INFLUENCE OF COMPACTION TEMPERATURE	10
4.1 Experimental Grid	10
4.2 Results and Discussion	10
4.3 Recommendations	13
5.0 INFLUENCE OF ANTI-STRIPPING TREATMENT	14
5.1 Experimental Grid	14
5.2 Results and Discussion	15
5.3 Recommendations	16
6.0 CONCLUSIONS	17
7.0 REFERENCES	18

Appendices

- Appendix A. Hamburg Wheel-Tracking Results from the Compaction Temperature Study
- Appendix B. Hamburg Wheel-Tracking Results from the Anti-Stripping Treatment Study

List of Tables

Table 1. Asphalt Cement Properties.	7
Table 2. Optimum Asphalt Contents for the Mixes Used in this Study.	9
Table 3. Experimental Grid for the Study to Determine the Influence of Compaction Temperature.	10
Table 4. Deformation (mm) After 20,000 Passes for Samples Compacted at Various Temperatures.	11
Table 5. Recommended Compaction Temperatures for Samples Tested in the Hamburg Wheel-Tracking Device.	13
Table 6. Experimental Grid for the Study to Determine the Influence of Anti-Stripping Treatment.	14
Table 7. Deformation (mm) After 20,000 Passes for Samples Treated with Various Anti-Stripping Treatments.	15

List of Figures

Figure 1. The Hamburg Wheel-Tracking Device.	3
Figure 2. Close-up of Hamburg Wheel Tracking Device.	3
Figure 3. Linear Kneading Compactor.	4
Figure 4. Schematic of the Linear Kneading Compactor.	4
Figure 5. Results from the Hamburg Wheel-Tracking Device.	6
Figure 6. Results from the Hamburg Wheel-Tracking Device Versus Compaction Temperature.	12

**Influence of Compaction Temperature and
Anti-Stripping Treatment on the Results
from the Hamburg Wheel-Tracking Device**

Tim Aschenbrener and Nava Far

1.0 INTRODUCTION

In September 1990, a group of individuals representing AASHTO, FHWA, NAPA, SHRP, AI, and TRB participated in a 2-week tour of six European countries. Information on this tour has been published in a "Report on the 1990 European Asphalt Study Tour" (1). Several areas for potential improvement of hot mix asphalt (HMA) pavements were identified, including the use of performance-related testing equipment used in several European countries. The Colorado Department of Transportation (CDOT) and the FHWA Turner-Fairbank Highway Research Center (TFHRC) were selected to demonstrate this equipment.

The first priority of the demonstration was to verify the predictive capabilities of this equipment by performing tests on mixtures of known field performance (2). The next step was to investigate several testing variables that influence the results in order to better understand the test results and their repeatability.

A previous study investigated the influence of four testing variables on results from the Hamburg wheel-tracking device (3): 1) test temperature, 2) air voids, 3) short-term aging, and 4) lime mixing. The purpose of this report is to identify the influence of two additional testing variables on the results. **The variables investigated in this study are 1) compaction temperature, and 2) anti-stripping treatment.** It is important to understand how these variables influence the test results so the laboratory procedure can be written to ensure repeatability. Further, these variables are also considered important to the moisture resistance of a pavement in the field. Any test that hopes to predict the moisture susceptibility of an HMA pavement should be sensitive to these variables.

2.0 HAMBURG WHEEL-TRACKING DEVICE

2.1 Equipment and Procedures

2.1.1 Hamburg Wheel-Tracking Device

The Hamburg wheel-tracking device is manufactured by Helmut-Wind Inc. of Hamburg, Germany as shown in Figures 1 and 2. A pair of samples are tested simultaneously. A sample is typically 260 mm (10.2 in.) wide, 320 mm (12.6 in.) long, and 40 mm (1.6 in.) deep. A sample's mass is approximately 7.5 kg (16.5 lbs.), and it is compacted to approximately 7% air voids. For this study, samples were compacted with the linear kneading compactor. The samples are submerged under water at 50°C (122°F), although the temperature can vary from 25°C to 70°C (77°F to 158°F). A steel wheel, 47 mm (1.85 in.) wide, loads the samples with 705 N (158 lbs.). The wheel makes 50 passes over each sample per minute. The maximum velocity of the wheel is 34 cm/sec (1.1 ft/sec) in the center of the sample. Each sample is loaded for 20,000 passes or until 20 mm of deformation occurs. Approximately 6-1/2 hours are required for a test.

2.1.2 Linear Kneading Compactor

The linear kneading compactor is shown in Figure 3 and is manufactured by R/H Specialty and Machine in Terre Haute, Indiana. The compactor can produce samples for direct use with both the Hamburg wheel-tracking device and the French rutting tester. Samples 320 x 260 mm (12.6 x 10.2 in.) and 40 mm (1.6 in.) or 80 mm (3.2 in.) thick can be produced on the Hamburg wheel-tracking device. Samples that are 500 mm x 180 mm (19.7 x 7.1 in.) and 50 mm (2 in.) thick can be produced for use on the French rutting tester. Additionally, two lifts of 50 mm can be used to make a 100 mm (4 in.) thick sample for the French rutting tester.

Since samples are compacted to a known height, the targeted air voids of the compacted sample are achieved easily. After determining the maximum specific gravity (AASHTO T 209) of the mix, the mold is filled with a pre-determined weight of material. The sample can typically be compacted within $\pm 1\%$ of the targeted air voids.



Figure 1. The Hamburg Wheel-Tracking Device.

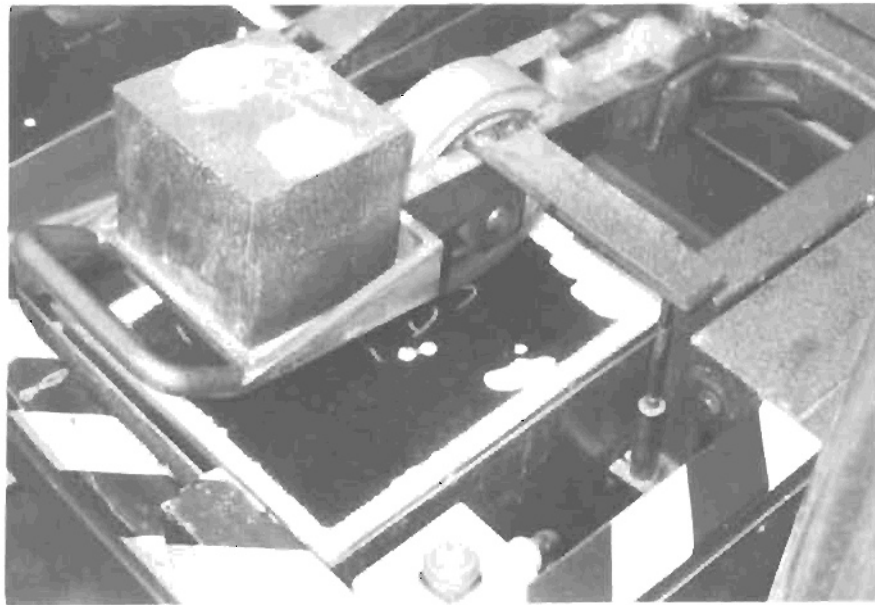

Figure 2. Close-up of Hamburg Wheel Tracking Device.

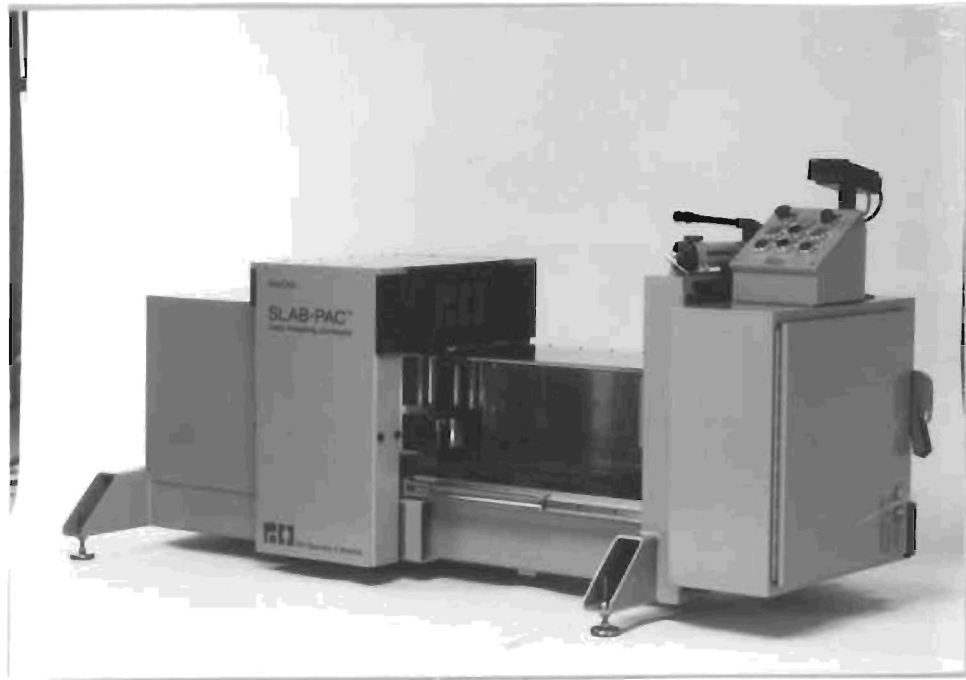

Figure 3. Linear Kneading Compactor.

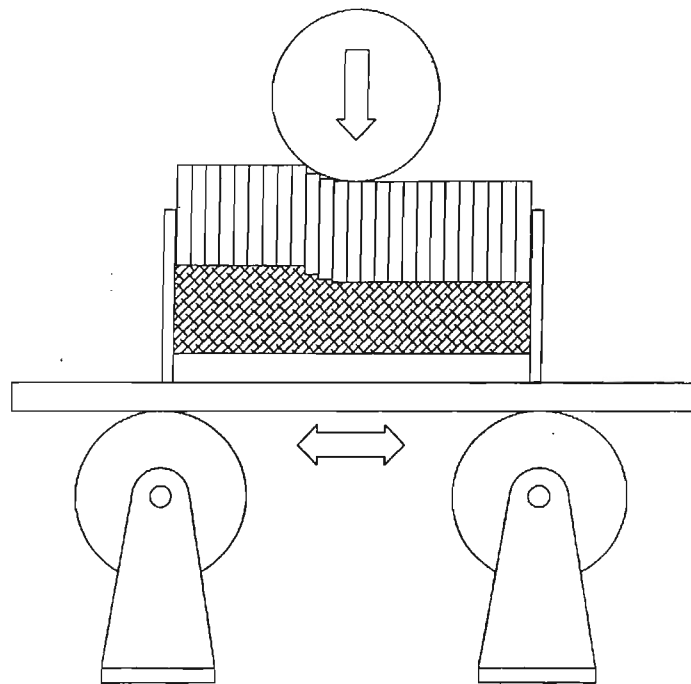

Figure 4. Schematic of the Linear Kneading Compactor.

A series of 12-mm (0.5-in.) wide steel plates are placed on the loose mix in the mold. A downward motion of the roller applies a force to the top of each plate while the mold moves back and forth on a sliding table shown in Figure 4. A linear compression wave is produced in the mix by the bottom edges of the plates as the roller pushes down on each plate. This kneading action allows the mix to be compacted without fracturing aggregate. This compactive action is probably very similar to a steel-wheel roller. The compaction time is less than 10 minutes.

2.2 Results and Specifications

The results from the Hamburg wheel-tracking device include the creep slope, stripping slope and stripping inflection point as shown in Figure 5. These results have been defined by Hines (4). The creep slope relates to rutting from plastic flow. It is the inverse of the rate of deformation in the linear region of the deformation curve, after post compaction effects have ended and before the onset of stripping. The stripping slope is the inverse of the rate of deformation in the linear region of the deformation curve, after stripping begins and until the end of the test. It is the number of passes required to create a 1 mm impression from stripping. The stripping slope is related to the severity of moisture damage. The stripping inflection point is the number of passes at the intersection of the creep slope and the stripping slope. It is related to the resistance of the HMA to moisture damage.

A sample is required by the City of Hamburg to have less than 4 mm rut depth after 20,000 passes. Testing by the CDOT has indicated this specification is very severe (2), and it was determined that a specification of 10 mm after 20,000 passes may be more reasonable for pavements in Colorado. The 10 mm specification was used for this study.

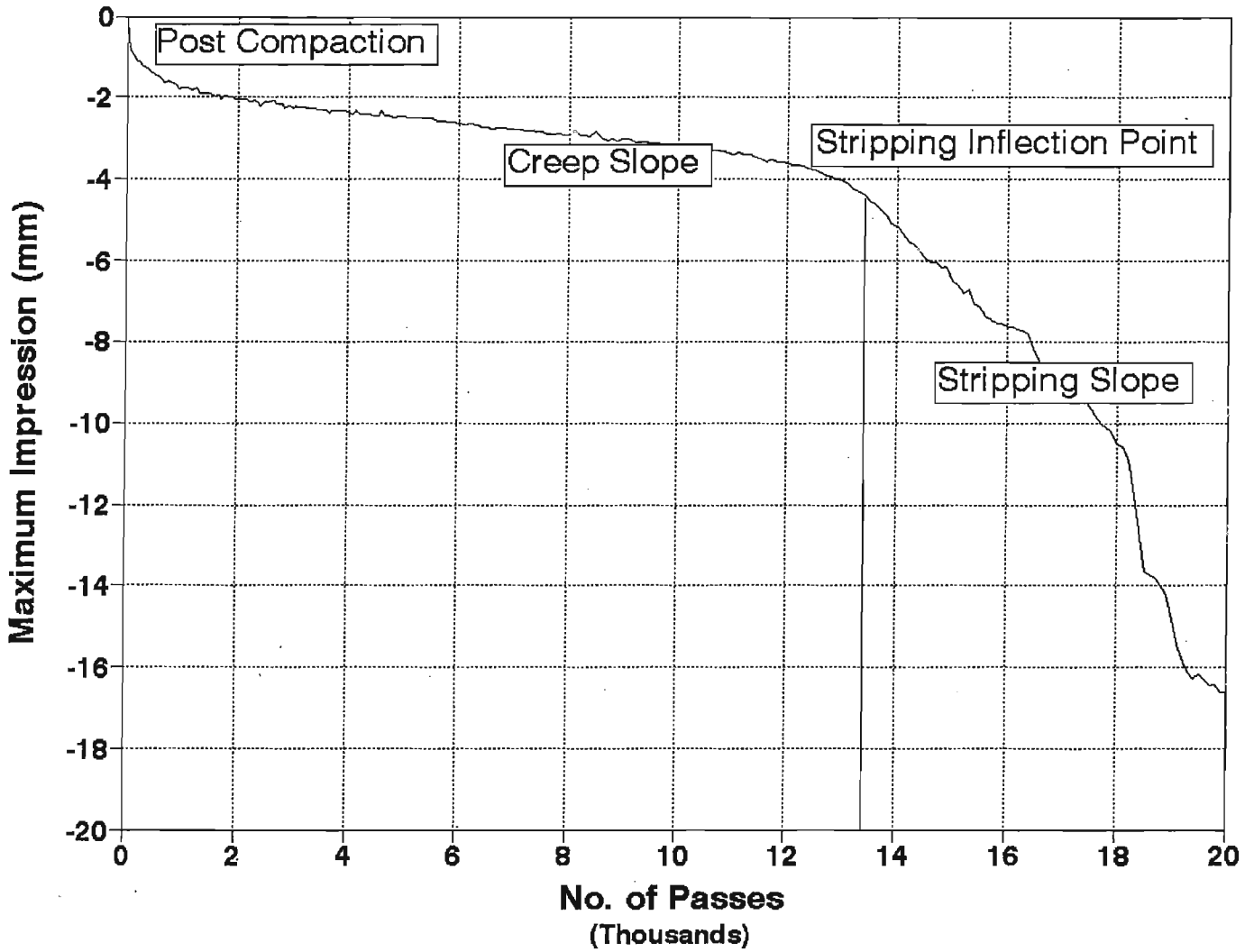

Figure 5. Results from the Hamburg Wheel-Tracking Device.

3.0 MATERIAL DESCRIPTIONS

3.1 Asphalt Cements

The asphalt cement used in this study was provided by Sinclair Refinery in Sinclair, Wyoming. The asphalt cement was an AC-20 (AASHTO M 226, Table 2). The properties of the asphalt cement were measured with the penetration at 25°C (AASHTO T 49), viscosity at 60°C (AASHTO T 202), ring and ball softening point (AASHTO T 53), and the SHRP Dynamic Shear Rheometer (DSR) tests. Results are shown in Table 1. For the DSR, the unaged asphalt cement would have a stiffness of 1.0 kPa at the temperature listed in Table 1. For the asphalt cement aged in the thin film oven test (TFOT) (AASHTO T 179), the temperature at which the asphalt cement would have a stiffness of 2.2 kPa is shown in Table 1. The possible high-temperature performance grade (PG) of the asphalt cement as classified by SHRP is included.

Table 1. Asphalt Cement Properties.

	Viscosity @ 60°C (poises)	Penetration @ 25°C (dmm)	Ring & Ball Softening Point (°C)	DSR (°C) @ 1 kPa Stiffness (Tank)	DSR (°C) @2.2 kPa Stiffness (TFOT)	High Temp. PG
AC-20	1850	61	52.8	66.4	64.4	64

3.2 Aggregates

Aggregates used for this study came from several different contractors and had a variety of performance histories. The aggregates and combinations were selected to provide a variety of results, good to poor, in the Hamburg wheel-tracking device. All mixtures used quarried aggregate. Two different types of natural sands were added to help vary the performance of each mixture.

The aggregates for Mix 1 were entirely from a quarried source that has had a history of good

performance. The aggregates for Mix 2 were primarily from a different quarry with a good history of performance. However, a poor quality natural sand was added. Although the natural sand is non-plastic, it does have clay present.

The aggregate for Mix 3 was from a quarry with a mixed history of good and marginal performance. A clean natural sand that has been associated with many HMA pavements that have stripped was added. The natural sand does not adhere to asphalt cement very well. The aggregate for Mix 4 was from a quarry with a history of poor performance. The quarry is highly variable, and the aggregates used for this study were from a good part of the quarry. The poor quality natural sand with clay used in Mix 2 was also added to Mix 4.

3.3 Hot Mix Asphalt

The optimum asphalt content for each of the mixtures was determined with the Texas gyratory in general accordance with ASTM D 4013. The pre-gyratory stress, end point stress and consolidation stress used were 210, 690, and 17,240 kPa (30, 100, 2500 psi), respectively. These stresses simulate the loads applied to the HMA pavements by high levels of traffic in Colorado.

For determining the optimum asphalt content, each HMA was mixed using its equi-viscous mixing temperature and then compacted using its equi-viscous compaction temperature. The optimum asphalt contents at 4% air voids are shown in Table 2. The asphalt contents were determined with hydrated lime in the mix. Since all mixes were 19.5 mm (3/4 in.) maximum nominal aggregate size, the minimum voids in the mineral aggregate (VMA) requirement was 13.0. The VMA for each mix is also shown in Table 2.

Each mix is different. It was not intended to compare Mix 1 with Mix 4, for example. The purpose of the study was to adjust one testing parameter and see how an individual mix acted as the testing variable was adjusted. Four different mixes were used to avoid having the results skewed by one "oddball" mix. Although the mixes are different, they are typical of commonly used mixes in Colorado.

All mixes had an anti-stripping treatment. Two types of liquid anti-stripping additives were provided by each of two different companies. When hydrated lime was used, it was provided by Chemical Lime Company.

Table 2. Optimum Asphalt Contents for the Mixes Used In this Study.

	Optimum Asphalt Content (%)	Air Voids at Optimum (%)	VMA (%)
Mix 1	5.2	4.0	13.8
Mix 2	5.1	4.0	14.4
Mix 3	5.2	4.0	14.1
Mix 4	5.1	4.0	13.5

4.0 INFLUENCE OF COMPACTION TEMPERATURE

The purpose of this study was to determine the influence of the compaction temperature on the results from the Hamburg wheel-tracking device.

4.1 Experimental Grid

The experimental grid is shown in Table 3. Each of the four different HMAs were mixed at the equi-viscous mixing temperature but were compacted at four different temperatures in the laboratory. The four different compaction temperatures used were: 66°C (150°F), 93°C (200°F), 121°C (250°F), and 149°C (300°F). These compaction temperatures represent a full range of compaction temperatures that could be encountered in the field. All of the samples were compacted in the laboratory with the linear kneading compactor. One testing temperature, 45°C, and one grade of asphalt cement, AC-20, were used for all HMAs in this experiment. All of the HMAs in this experiment contained hydrated lime.

Table 3. Experimental Grid for the Study to Determine the Influence of Compaction Temperature.

	Compaction Temperature			
	66°C	93°C	121°C	149°C
Mix 1	X	X	X	X
Mix 2	X	X	X	X
Mix 3	X	X	X	X
Mix 4	X	X	X	X

X - Replicate samples were tested. All samples were mixed with AC-20 and tested at 45°C.

4.2 Results and Discussion

All samples were compacted to 6.5% \pm 1.5% air voids. The average deformations measured

from the replicate samples tested in the Hamburg wheel-tracking device after 20,000 passes is shown in Table 4. A plot of the deformation versus the compaction temperature for each of the HMAs is shown in Figure 6. Clearly, as the sample compaction temperature is increased, the test results from the Hamburg wheel-tracking device improve.

Table 4. Deformation (mm) After 20,000 Passes for Samples Compacted at Various Temperatures.

	Compaction Temperature			
	66°C	93°C	121°C	149°C
Mix 1	(>20)	7.9	7.0	1.4
Mix 2	(>20)	(13.9)	(11.4)	2.3
Mix 3	(>20)	(>20)	9.2	2.5
Mix 4	(>20)	8.6	10.0	2.3

() - Indicates unacceptable test result based on 10 mm.

In a previous study (5), loose HMA was sampled behind the paver, and slabs of field compacted HMA were sawn from the same location at a later time. The loose HMA that was compacted in the laboratory did consistently better in the Hamburg wheel-tracking device than the slabs of field compacted HMA that were sawn from the pavement. The compaction temperature in the laboratory was consistently higher than the compaction temperature in the field. It is entirely possible that the difference in performance in the Hamburg wheel-tracking device between the laboratory and field compacted samples was the compaction temperature.

Compaction temperature significantly influences the results from the Hamburg wheel-tracking device. The higher the compaction temperature, the better the results.

It should also be noted that the more short-term aging a sample receives, the better the results in the Hamburg wheel-tracking device. The samples compacted in this study were mixed in the laboratory, placed in closed containers, placed in an oven for 4 hours at the compaction temperature, and then compacted. The higher the temperature, the more short-term aging the

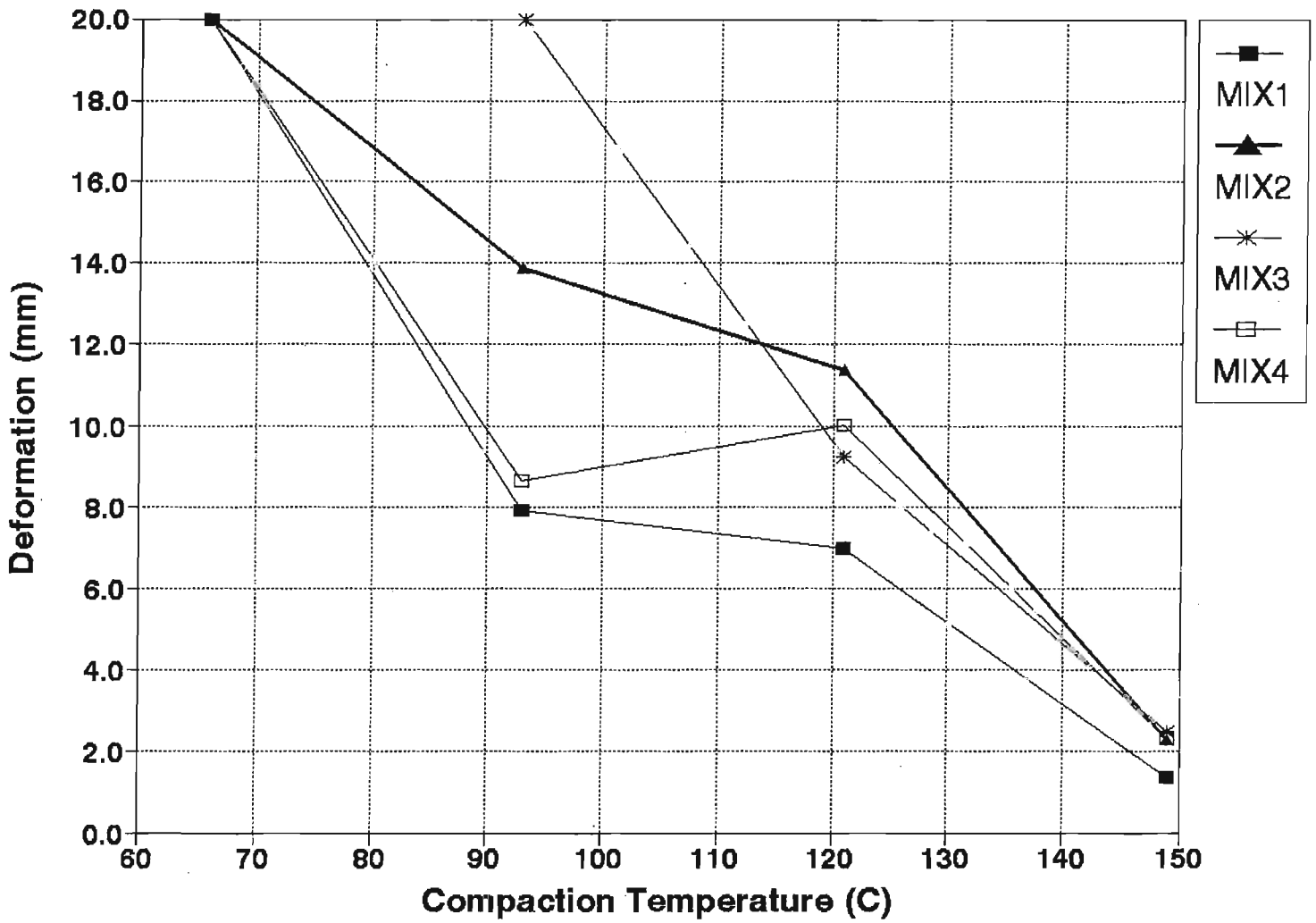

Figure 6. Results from the Hamburg Wheel-Tracking Device Versus Compaction Temperature.

HMA receives. It is possible that the samples compacted at higher temperatures received additional short-term aging.

4.3 Recommendations

Currently, the CDOT standard specifications allow no further compactive effort in the field when the temperature of the surface falls below 85°C (185°F). Based on results from this study, it appears that this specification should be enforced. Based on the projects visited for a short-term aging study currently underway and a previous laboratory study (5), this specification was generally not enforced. The specified density was typically achieved before the minimum compaction temperature was achieved, but rollers continued to compact the mat anyway. The higher the temperature that field compaction can be achieved; the better the results in the Hamburg wheel-tracking device. If compaction can be achieved at higher temperatures in the field, it is then likely the pavement will perform longer. Poor performance at low temperatures can be explained because of either 1) micro-cracking of the HMA, 2) broken aggregate, and/or 3) interconnected air voids.

When compacting samples in the laboratory, it is important to standardize the compaction temperatures. The standardization is important for repeatability concerns. The recommended compaction temperatures are shown in Table 5. These temperatures coincide with the equi-viscous compaction temperatures of asphalt cements used in Colorado.

Table 5. Recommended Compaction Temperatures for Samples Tested in the Hamburg Wheel-Tracking Device.

Grade	Compaction Temperature
AC-5	127 \pm 3°C (260 \pm 5°F)
AC-10	135 \pm 3°C (275 \pm 5°F)
AC-20	135 \pm 3°C (275 \pm 5°F)
Polymers	150 \pm 3°C (302 \pm 5°F)

5.0 INFLUENCE OF ANTI-STRIPPING TREATMENT

The purpose of this study was to determine the influence of anti-stripping treatment on the results from the Hamburg wheel-tracking device. The purpose of this study was not to compare lime and liquid anti-stripping additives, but to see if the Hamburg wheel-tracking device was sensitive to anti-stripping treatments.

5.1 Experimental Grid

The experimental grid is shown in Table 6. Samples were prepared with no anti-stripping treatment, liquid anti-stripping additives, and hydrated lime. Two different manufacturers, A and B, each provided two different types of liquid anti-stripping additives, 1 and 2. These anti-stripping treatments represent a full range of the types of additives used in Colorado. All of the samples compacted in the laboratory were compacted with the linear kneading compactor. Four HMAs with different performance histories were used. One testing temperature, 45°C, and one grade of asphalt cement, AC-20, were used for all HMAs in this experiment.

Table 6. Experimental Grid for the Study to Determine the Influence of Anti-Stripping Treatment.

	No Treatment	1% Hydrated Lime	Additive "A"		Additive "B"	
			Type "1"	Type "2"	Type "1"	Type "2"
Mix 1	X	X	X	X	X	X
Mix 2	X	X	X	X	X	X
Mix 3	X	X	X	X	X	X
Mix 4	X	X	X	X	X	X

X - Replicate samples were tested. All samples were mixed with AC-20 and tested at 45°C.

5.2 Results and Discussion

All samples were compacted to $6.5\% \pm 1.5\%$ air voids. The average deformation measured from the replicate samples tested in the Hamburg wheel-tracking device measured after 20,000 passes are shown in Table 7. Only one of the four mixes tested in this study would have passed the Hamburg wheel-tracking device without treatment (Mix 4). In all cases, treating the HMA with hydrated lime or liquid anti-stripping additives improved the results.

Table 7. Deformation (mm) After 20,000 Passes for Samples Treated with Various Anti-Stripping Treatments.

	No Treatment	1% Hydrated Lime	Additive "A"		Additive "B"	
			Type "1"	Type "2"	Type "1"	Type "2"
Mix 1	(17.0)	1.4	2.2	3.1	6.3	7.4
Mix 2	(>20)	2.3	8.1	8.4	5.3	(14.6)
Mix 3	(>20)	2.5	(13.7)	8.5	(>20)	(12.4)
Mix 4	8.7	2.3	6.2	4.6	5.0	4.3

() - Indicates unacceptable test result based on 10 mm.

When no treatment was used, three of the mixes did not make 20,000 passes; they failed quickly. One of the mixes passed the test.

The use of hydrated lime improved the results for each of the mixes dramatically. All mixes would have passed the very severe requirement of 4 mm used by the City of Hamburg when hydrated lime was used.

Liquid anti-stripping additives were added at a rate of 0.5% by weight of asphalt cement; the typical rate recommended by the manufacturers. When liquid anti-stripping additives were used, test results from the Hamburg wheel-tracking device were always better than the mixes that received no treatment. However, the results from the samples treated with liquid anti-stripping additives did not always pass the specification of 10 mm adopted by the CDOT. With some

aggregates, the liquid anti-stripping additives improved the HMA dramatically, while in other cases the results were not improved very much at all.

It should be noted that the mix designs were performed with hydrated lime. If the mix designs had been performed with liquid anti-stripping additives, there would probably have been 0.2% to 0.3% additional asphalt cement. Therefore, it is not entirely fair to compare the hydrated lime and liquid anti-stripping additive test results.

Hydrated lime always worked better than the liquid anti-stripping additives, although hydrated lime would probably be considered equal to Additive "A" for Mix 1. Some of the liquid anti-stripping additives improved some of the HMAs dramatically and produced similar results as the hydrated lime. In other instances, the liquid anti-stripping additives did not perform as good as lime.

5.3 Recommendations

Since there is no panacea for stripping resistance, the HMA needs to be tested. Currently, the CDOT uses hydrated lime. Hydrated lime generally has done an excellent job at preventing moisture distress in the Hamburg wheel-tracking device and in the field. It appears that there are some liquid anti-stripping additives that will work just as well as hydrated lime with some aggregates.

Until performance related tests are adopted that can accurately identify the performance of the HMA with respect to moisture damage, the CDOT will continue specifying the use of hydrated lime in HMA.

6.0 CONCLUSIONS

The variables investigated in this study were 1) compaction temperature, and 2) anti-stripping treatment. These variables can influence the test results so the laboratory procedure should be written to include tight control on these variables to ensure repeatability. Additionally, these variables are also considered important to the moisture resistance of a pavement in the field. Any test that hopes to predict the moisture susceptibility of an HMA pavement should be sensitive to these variables.

1) The compaction temperature can influence the results in the Hamburg wheel-tracking device. The higher the compaction temperature, the better the results in the Hamburg wheel-tracking device. The recommended laboratory compaction temperatures are provided in Table 5. It is recommended to achieve compaction at the highest possible temperature in the field.

2) The use of hydrated lime and liquid anti-stripping additives improved the results in the Hamburg wheel-tracking device over HMAs that were not treated. Hydrated lime dramatically improved the HMAs that were not treated. Liquid anti-stripping additives improved some of the HMAs dramatically while other HMAs were only improved slightly.

7.0 REFERENCES

1. Report on the 1990 European Asphalt Study Tour (June 1991), American Association of State Highway and Transportation Officials, Washington, D.C., 115+ pages.
2. Aschenbrener, T., R.L. Terrel, and R.A. Zamora (1994), "Comparison of the Hamburg Wheel-Tracking Device and the Environmental Conditioning System to Pavements of Known Stripping Performance," Colorado Department of Transportation, CDOT-DTD-R-94-1, 101 pages.
3. Aschenbrener, T. and G. Currier, (1993), "Influence of Testing Variables on the Results from the Hamburg Wheel-Tracking Device," Colorado Department of Transportation, CDOT-DTD-R-93-22, 116 pages.
4. Hines, Mickey (1991), "The Hamburg Wheel-Tracking Device," Proceedings of the Twenty-Eighth Paving and Transportation Conference, Civil Engineering Department, The University of New Mexico, Albuquerque, New Mexico.
5. Stevenson, J.D. and T. Aschenbrener (1994), "Comparison of Test Results from Laboratory and Field Compacted Samples," Colorado Department of Transportation, CDOT-DTD-R-94-3, 92 pages.

Appendix A

Hamburg Wheel-Tracking Results from the Compaction Temperature Study

Mix1, 66 C Compaction
Test Temperature = 45 C

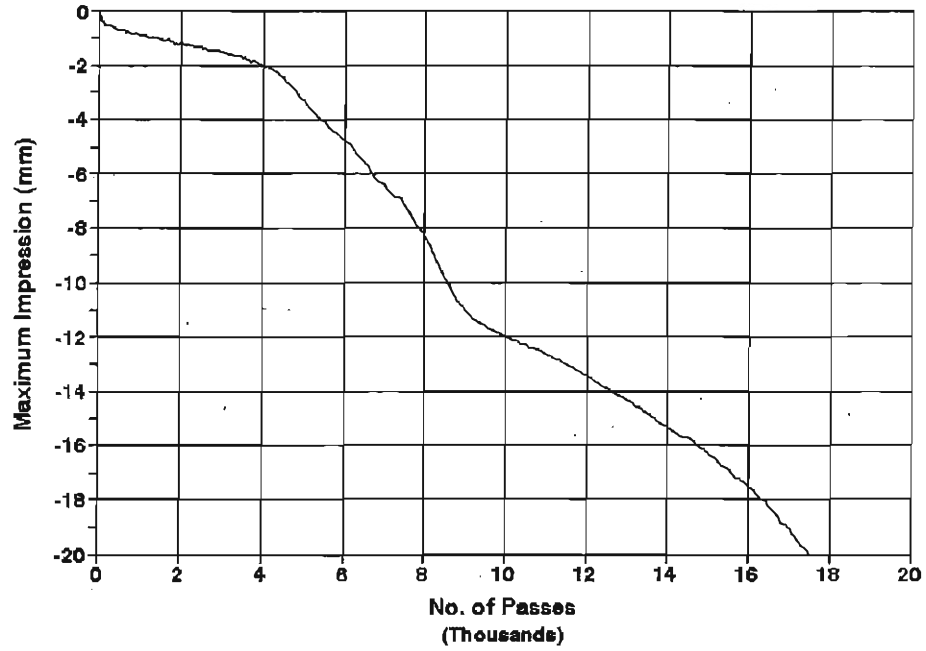

Mix2, 66 C Compaction
Test Temperature = 45 C

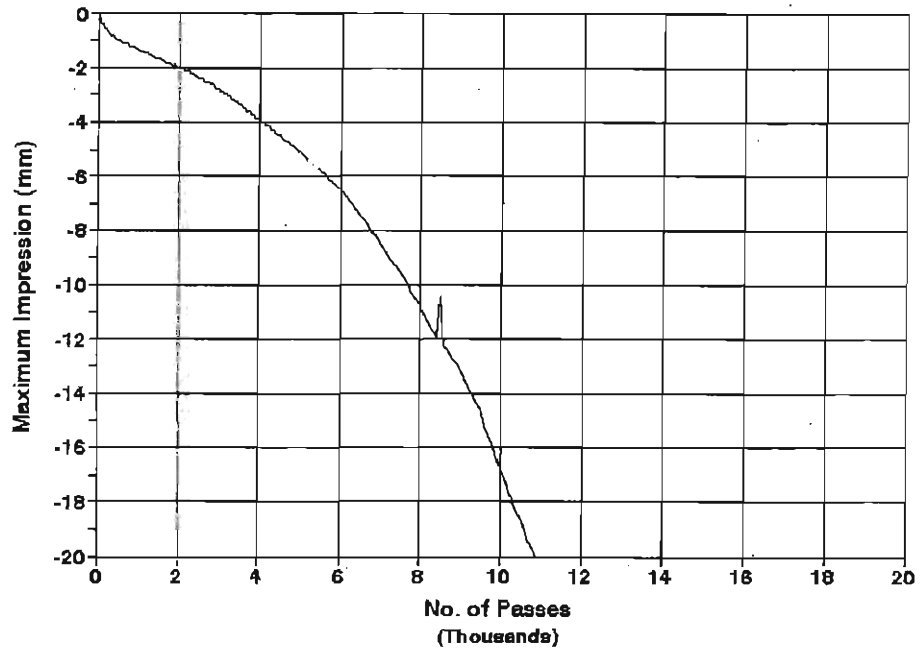

Mix3, 66 C Compaction
Test Temperature = 45 C

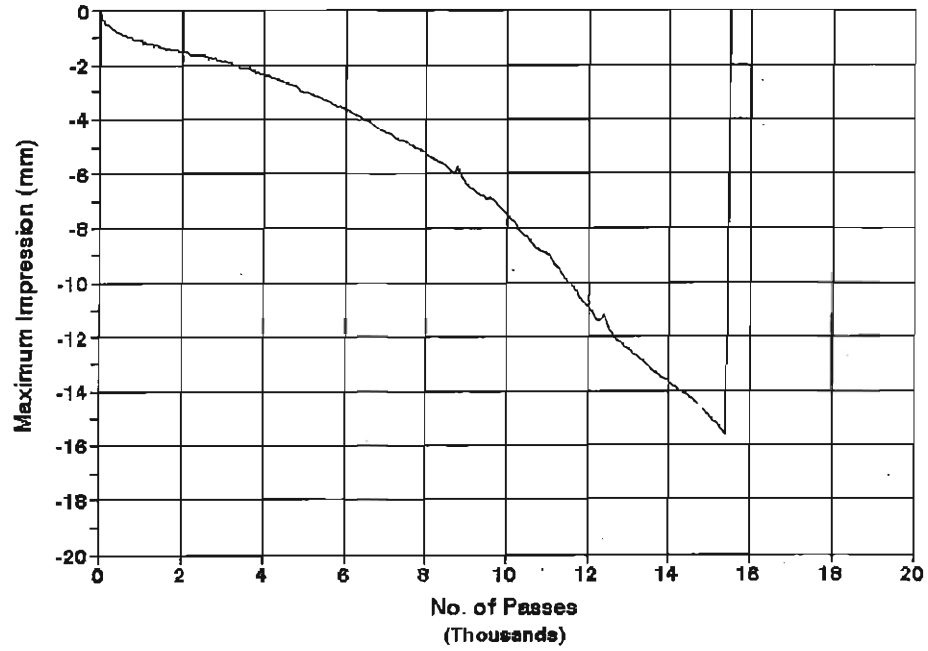

Mix4, 66 C Compaction
Test Temperature = 45 C

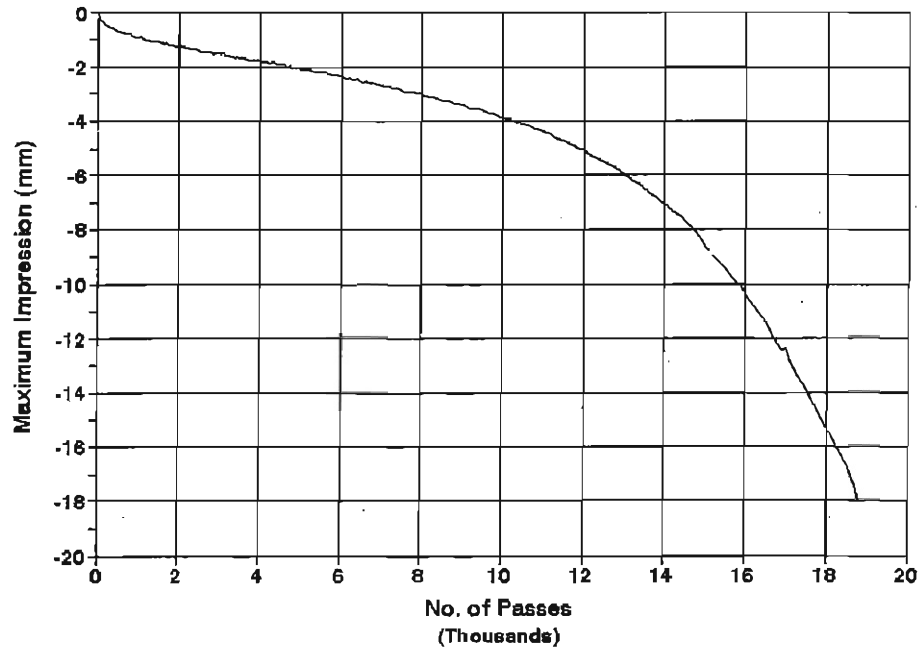

Mix1, 93 C Compaction
Test Temperature = 45 C

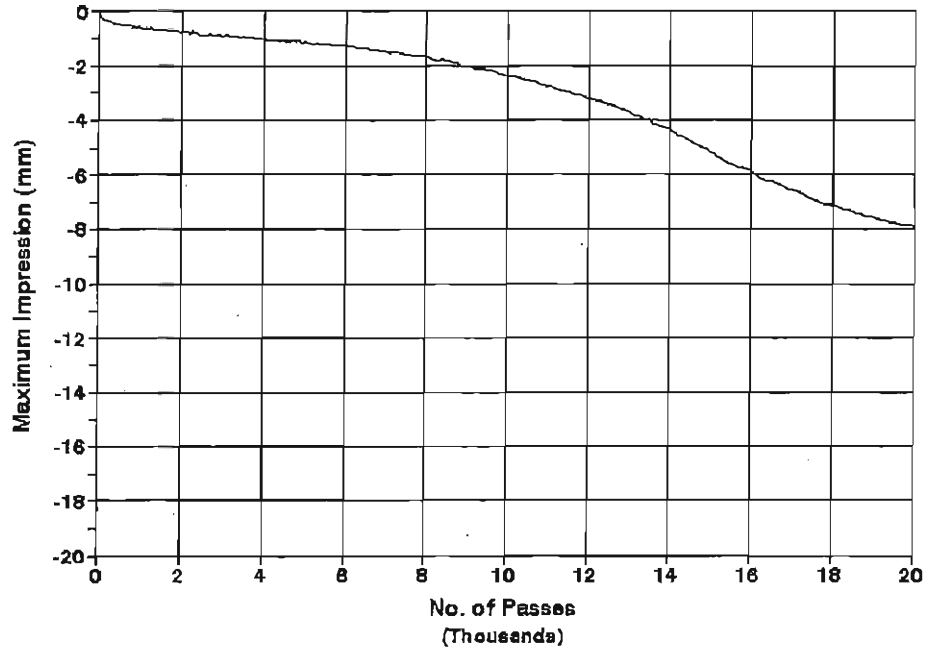

Mix2, 93 C Compaction
Test Temperature = 45 C

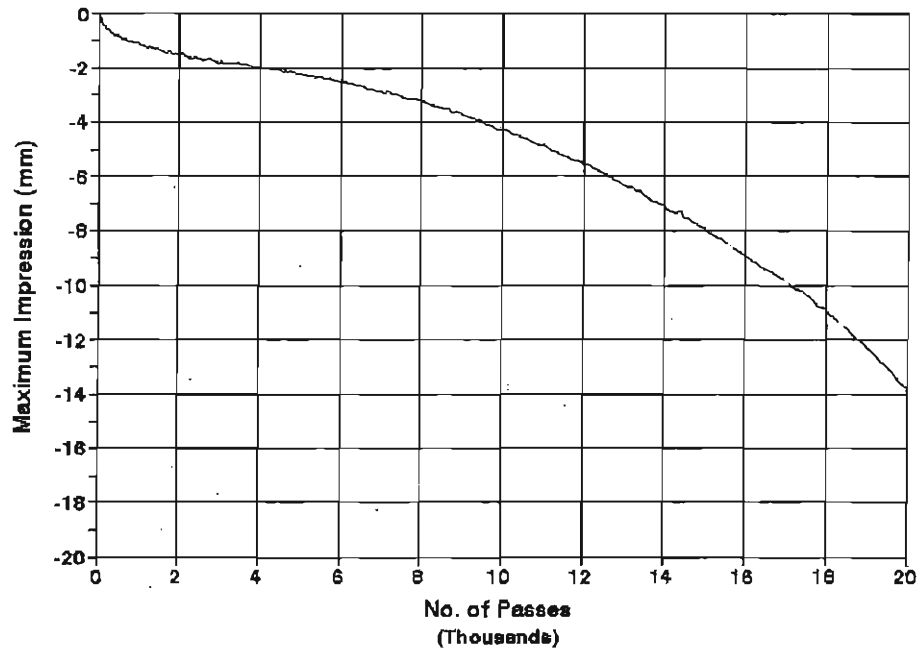

Mix3, 93 C Compaction
Test Temperature = 45 C

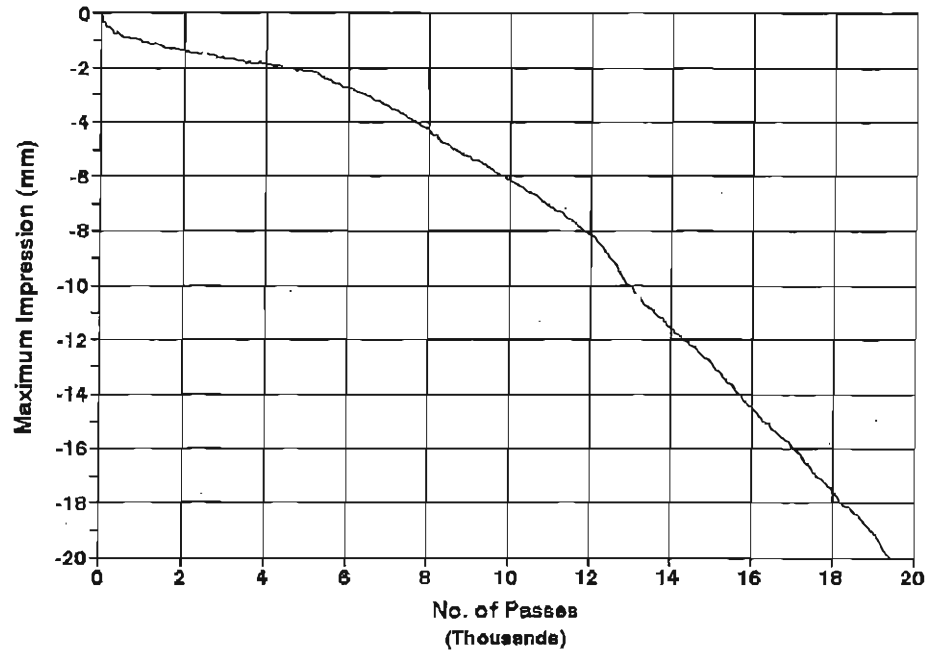

Mix4, 93 C Compaction
Test Temperature = 45 C

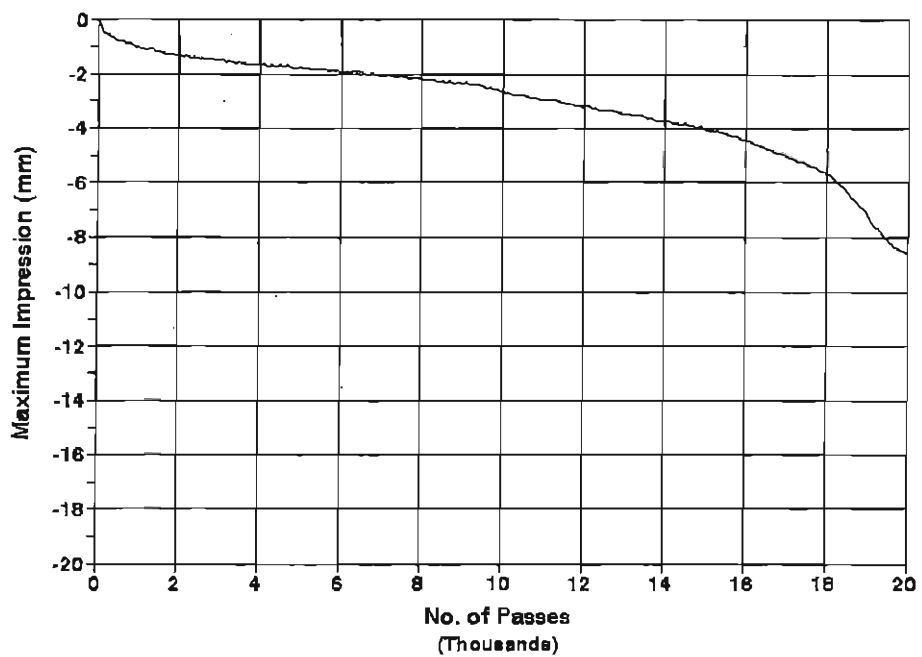

Mix1, 121 C Compaction
Test Temperature = 45 C

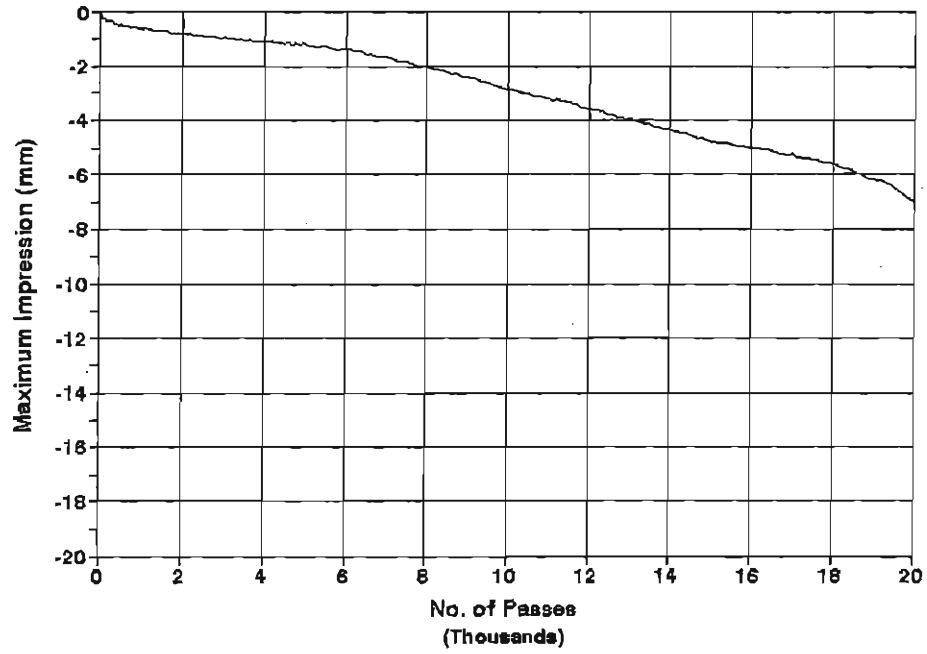

Mix2, 121 C Compaction
Test Temperature = 45 C

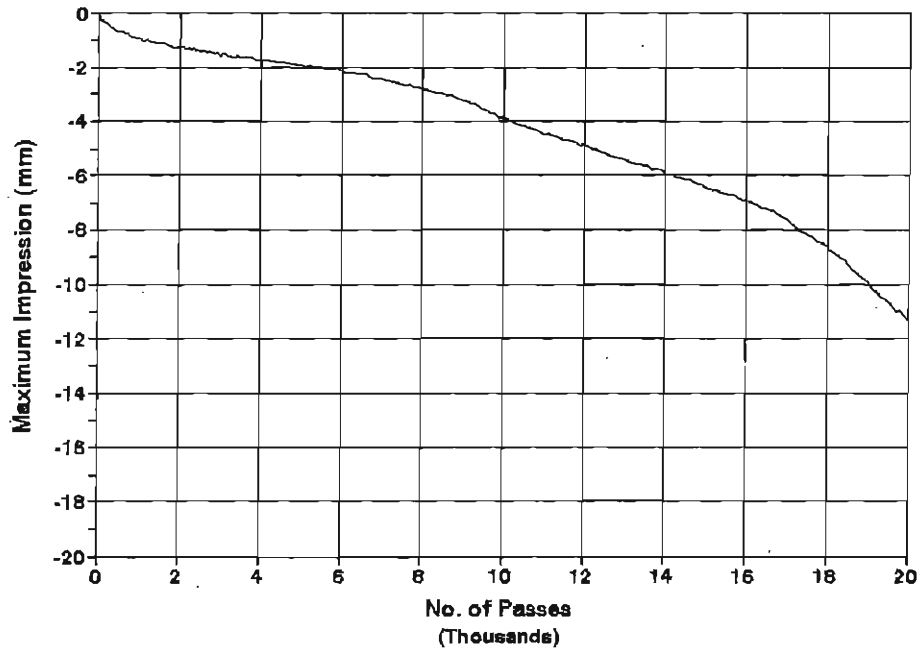

Mix3, 121 C compaction
Test Temperature = 45 C



Mix4, 121 C Compaction
Test Temperature = 45 C

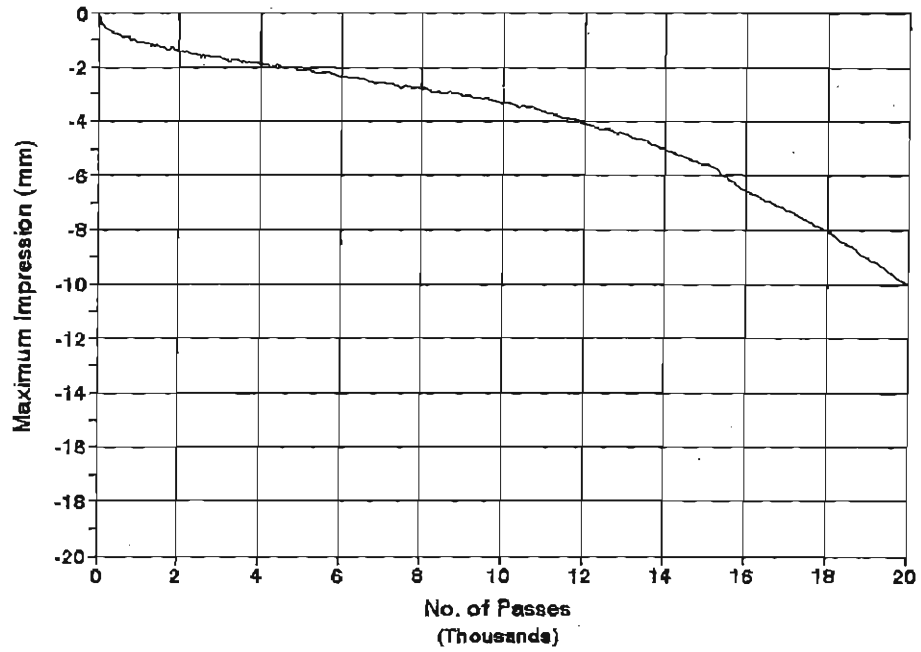

Appendix B

Hamburg Wheel-Tracking Results from the Anti-Stripping Treatment Study

Mix1, No Treatment
Test Temperature = 45 C

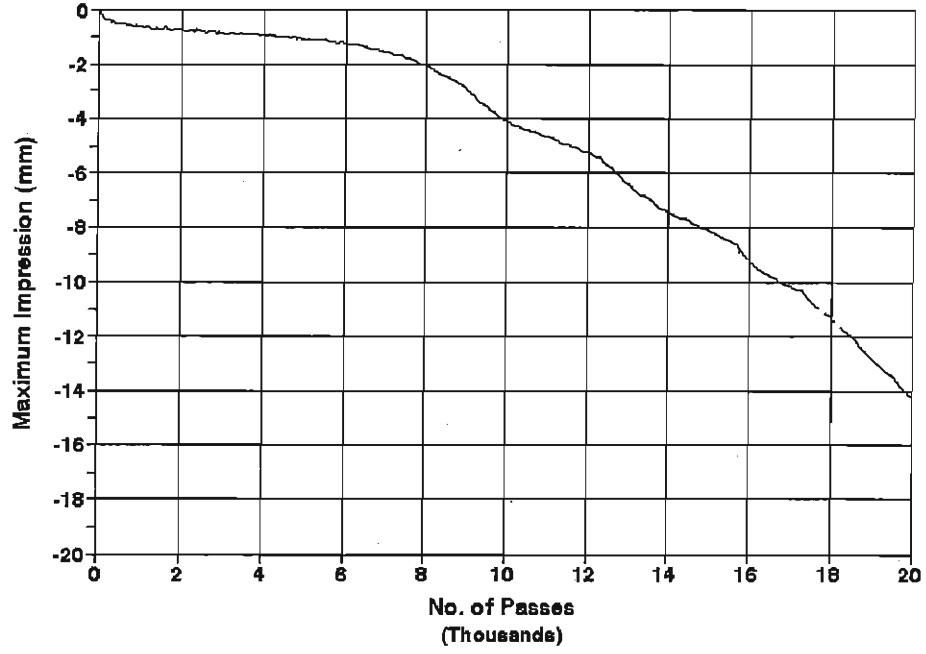

Mix2, No Treatment
Test Temperature = 45 C



Mix3, No Treatment
Test Temperature = 45 C

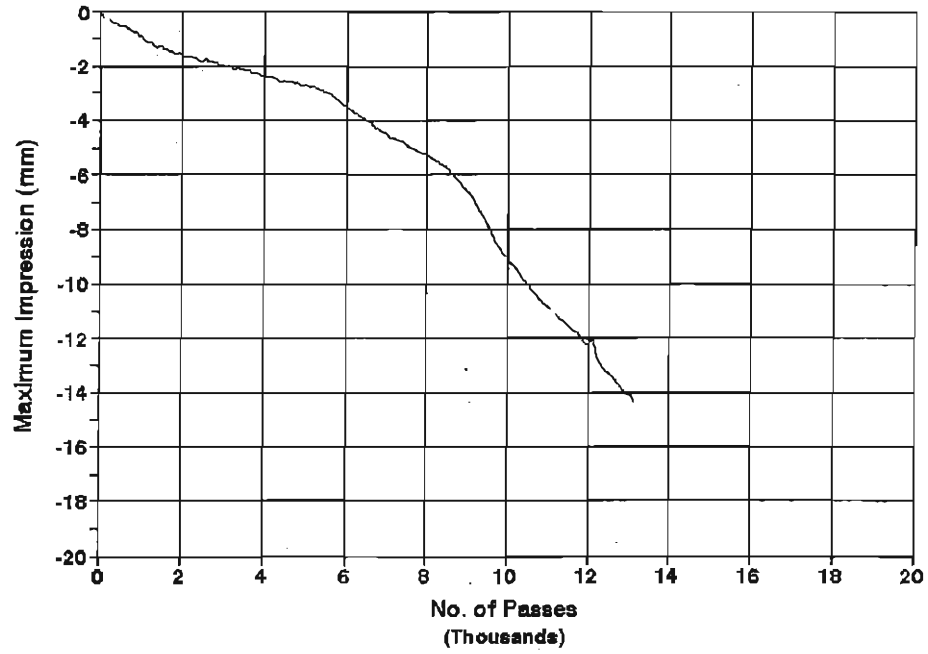

Mix4, No Treatment
Test Temperature = 45 C

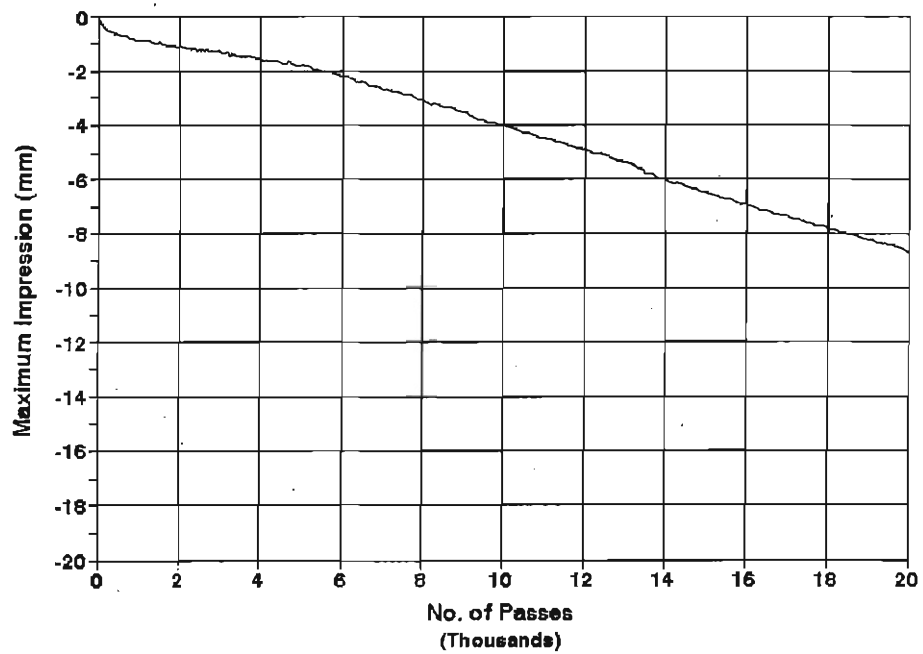

Mix1, Hydrated Lime
Test Temperature = 45 C

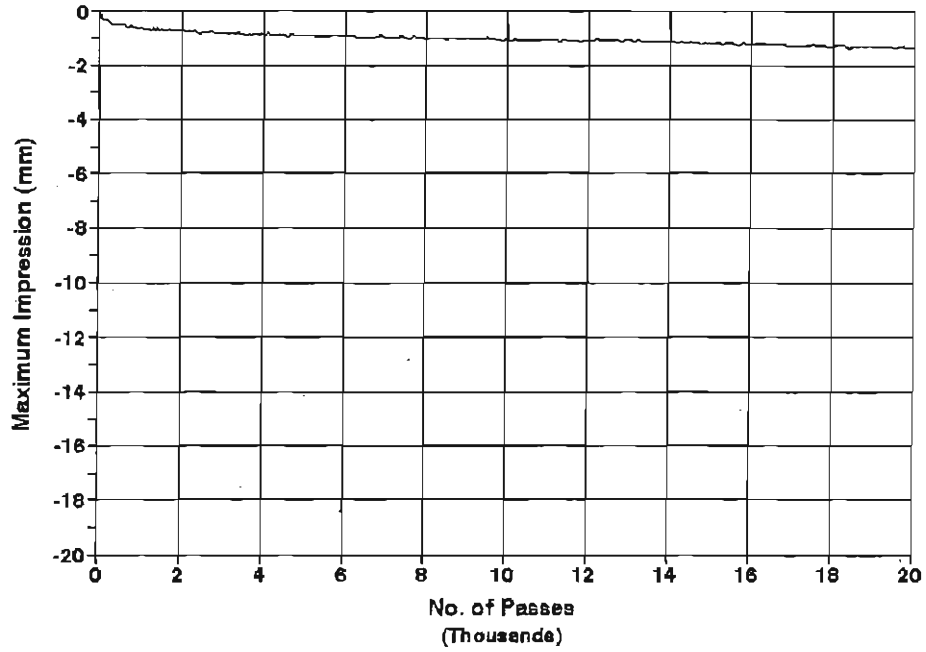

Mix2, Hydrated Lime
Test Temperature = 45 C

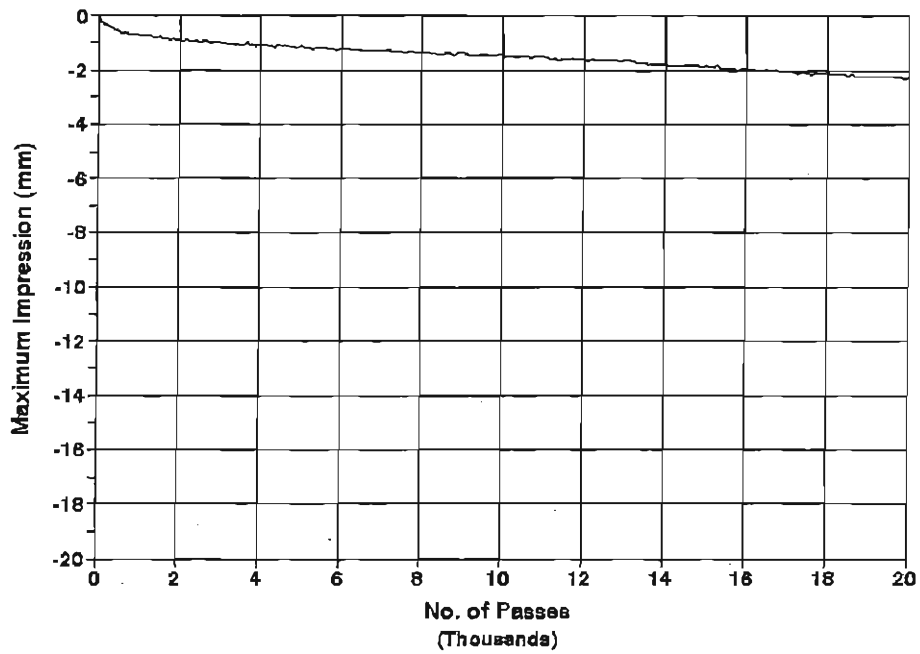

Mix3, Hydrated Lime
Test Temperature = 45 C

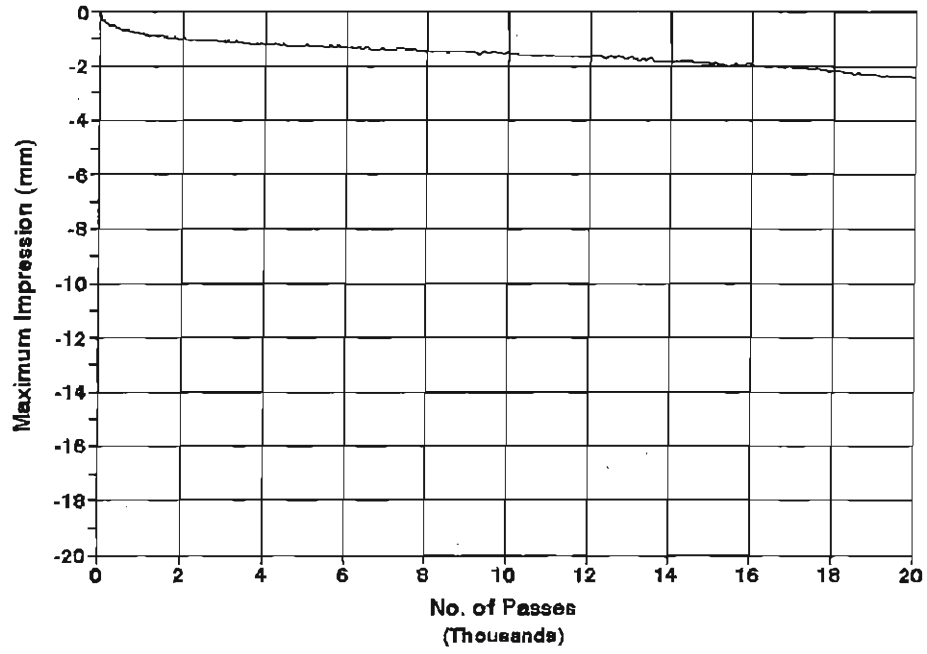

Mix4, Hydrated Lime
Test Temperature = 45 C

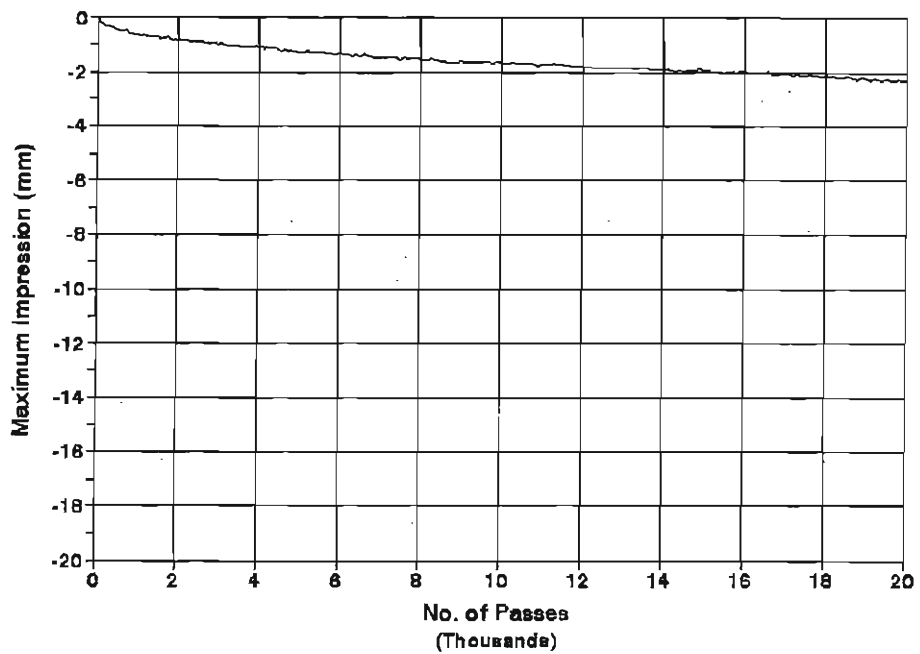

Mix1, Additive A, Type1
Test Temperature = 45 C

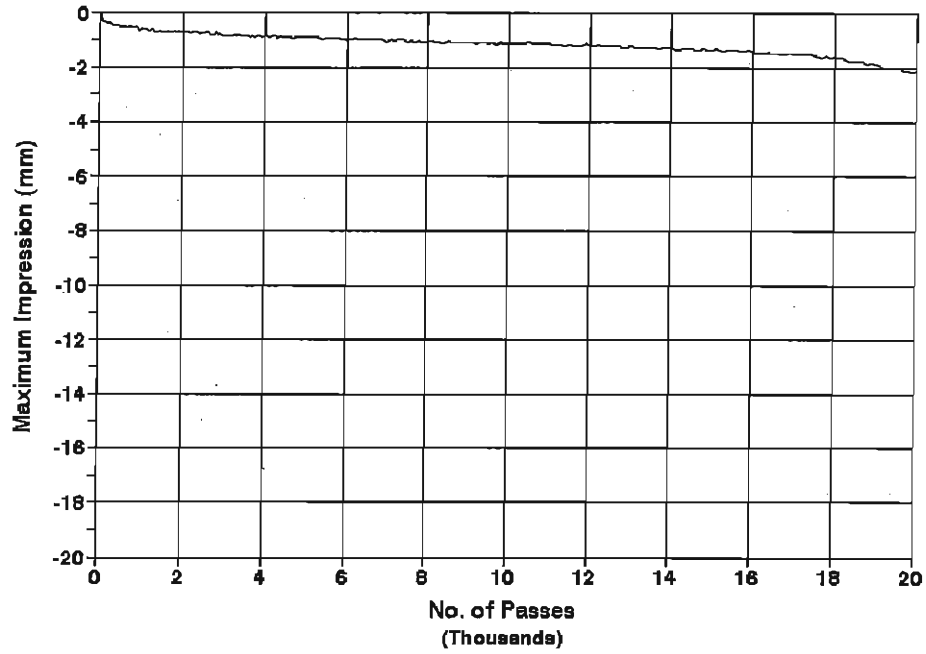

Mix2, Additive A, Type1
Test Temperature = 45 C

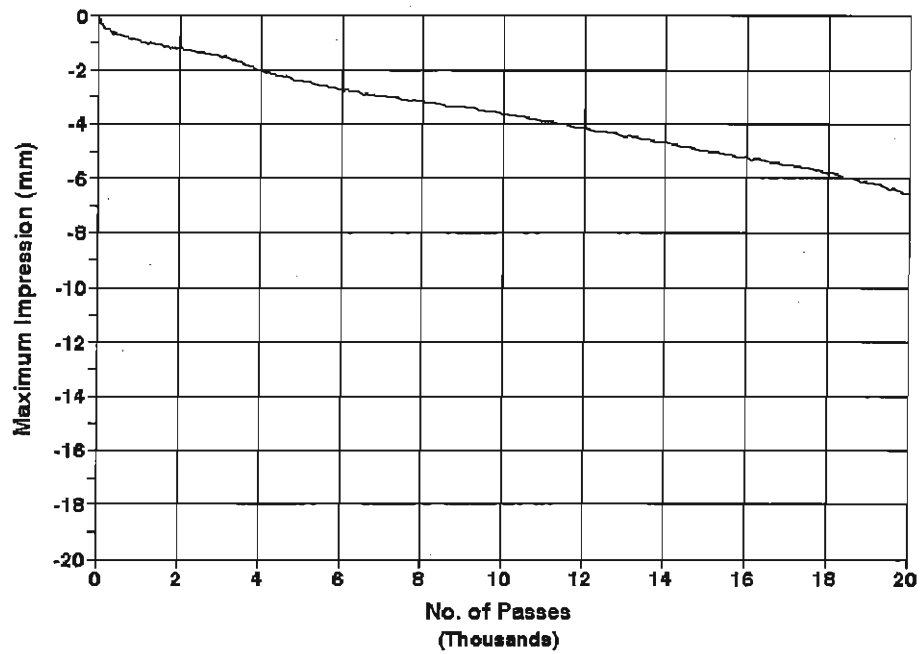

Mix3, Additive A, Type1
Test Temperature = 45 C

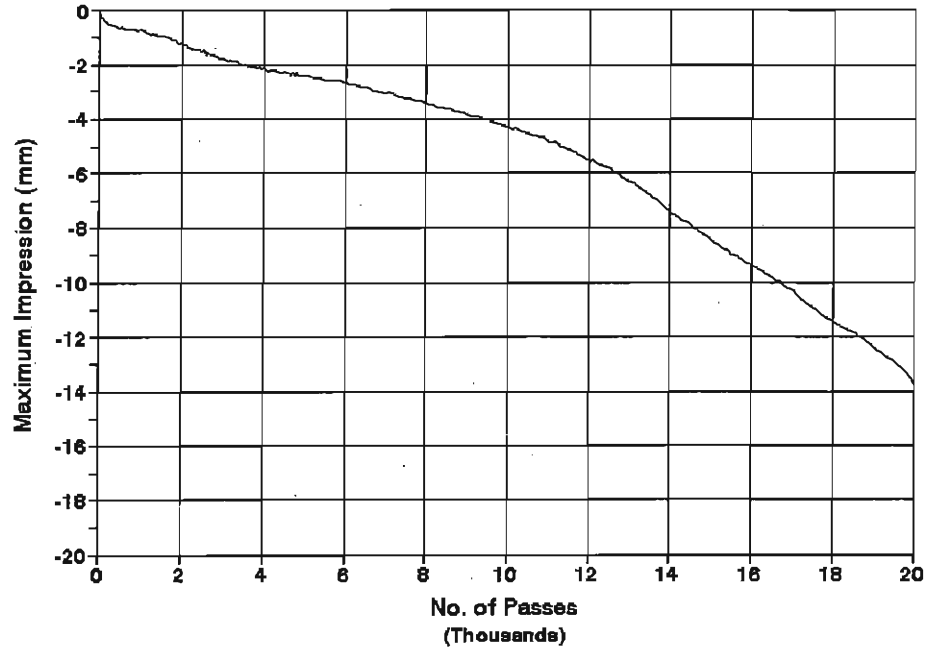

Mix4, Additive A, Type1
Test Temperature = 45 C

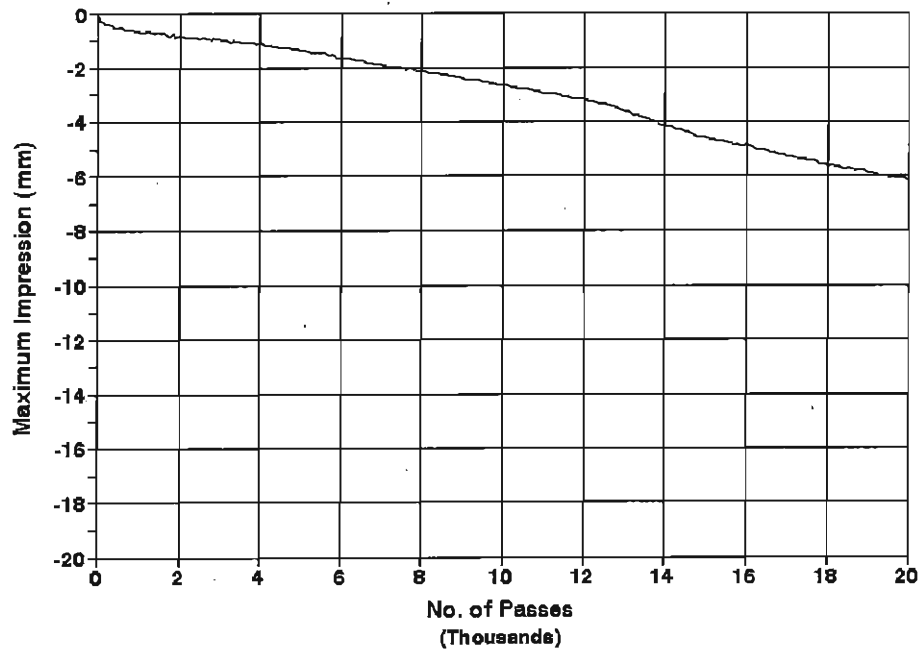

Mix1, Additive A, Type2
Test Temperature = 45 C

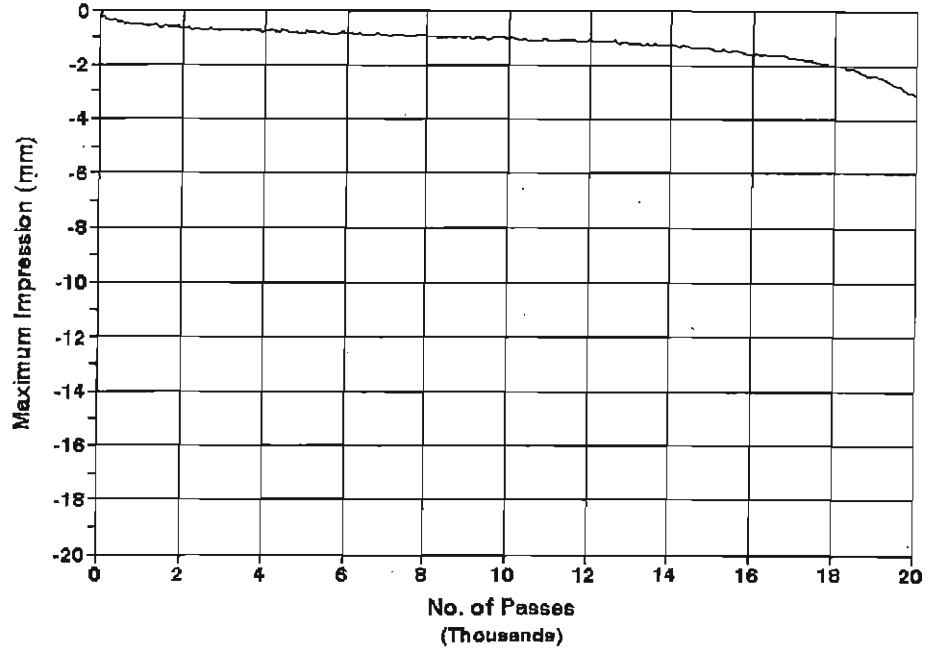

Mix2, Additive A, Type2
Test Temperature = 45 C

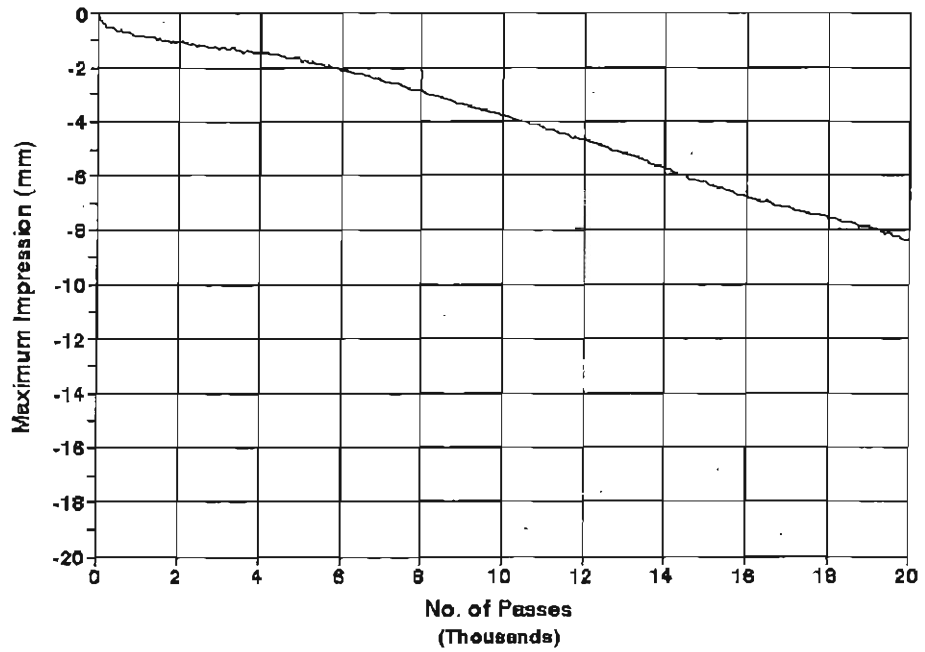

Mix3, Additive A, Type2
Test Temperature = 45 C

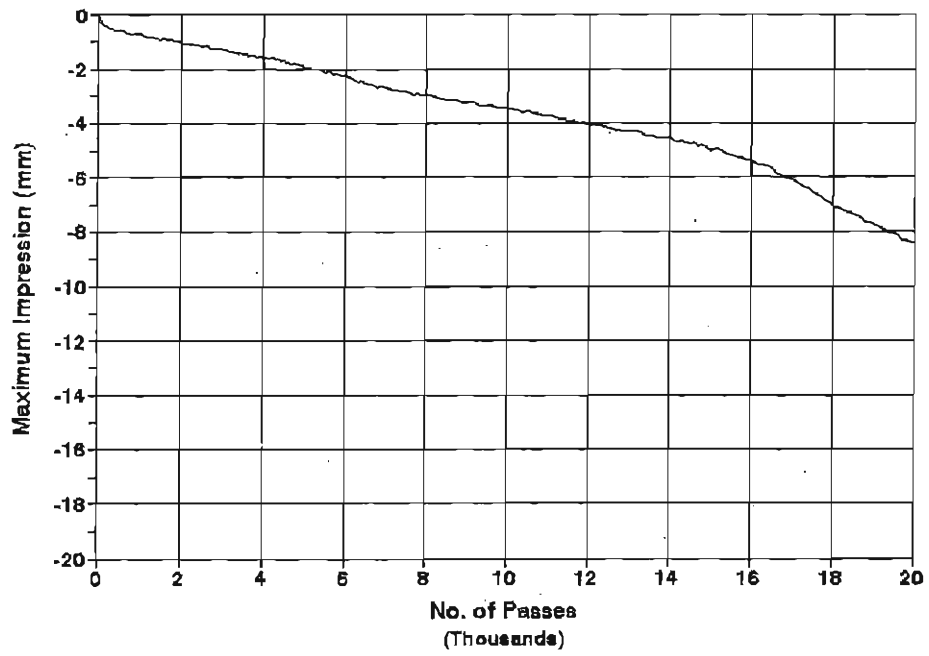

Mix4, Additive A, Type2
Test Temperature = 45 C

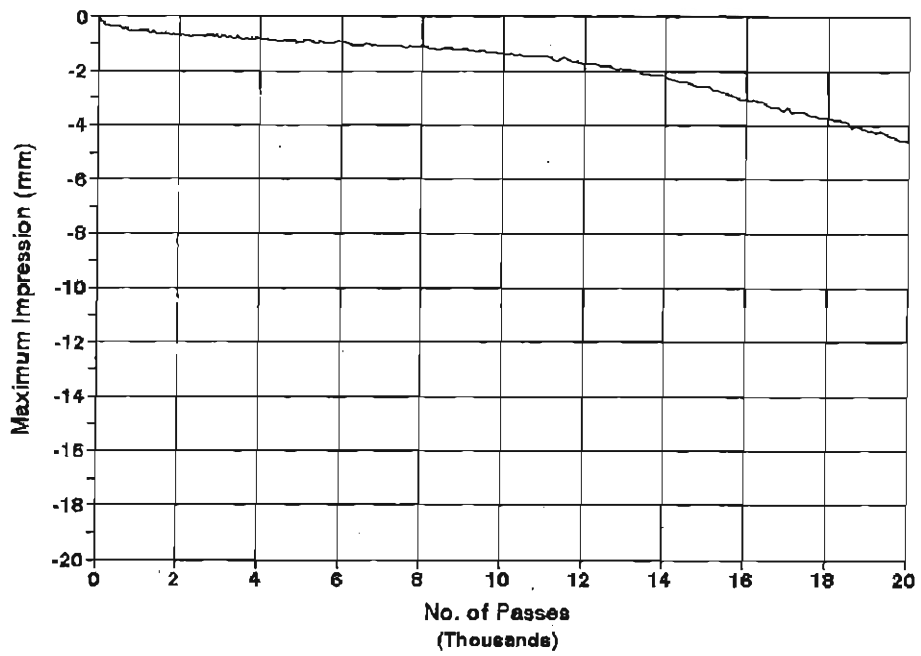

Mix1, Additive B, Type1
Test Temperature = 45 C

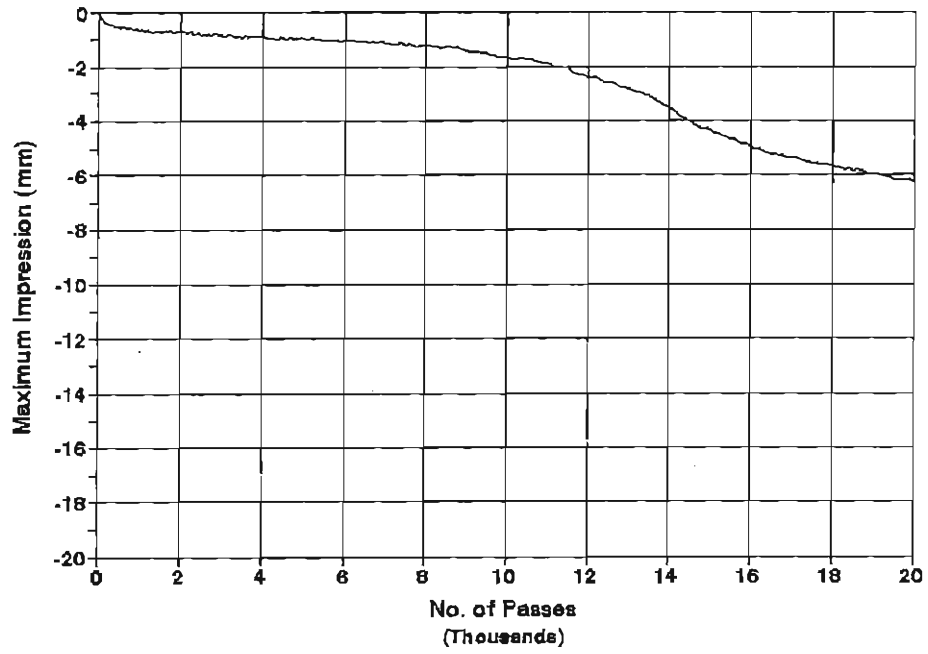

Mix2, Additive B, Type1
Test Temperature = 45 C

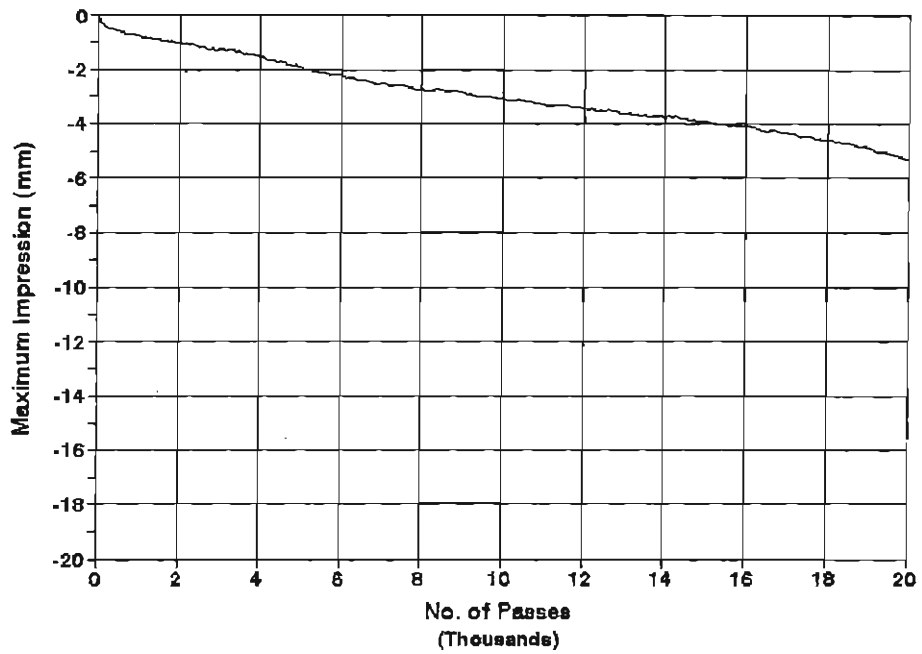

Mix3, Additive B, Type1
Test Temperature = 45 C



Mix4, Additive B, Type1
Test Temperature = 45 C

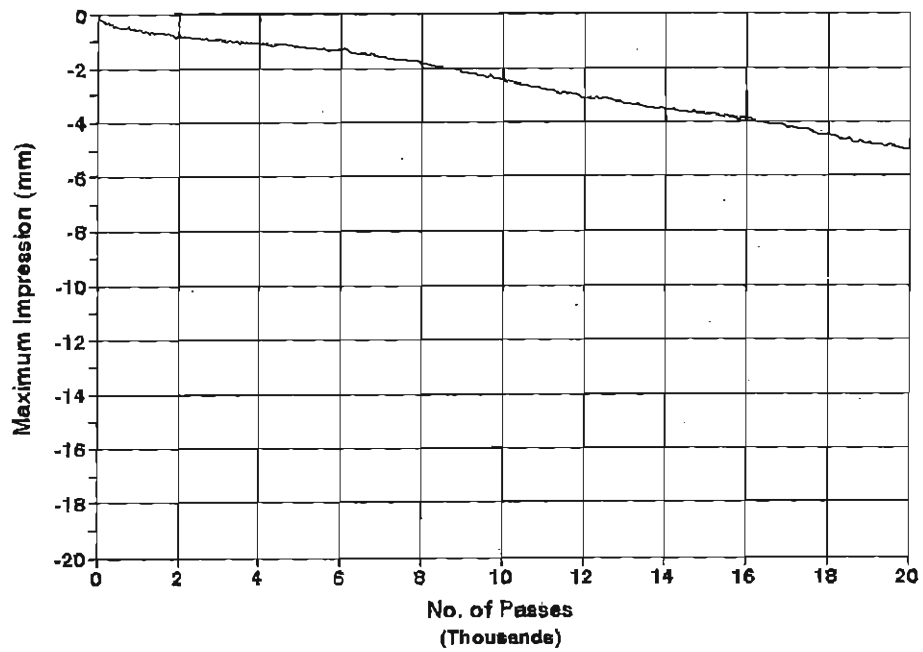

Mix1, Additive B, Type2
Test Temperature = 45 C

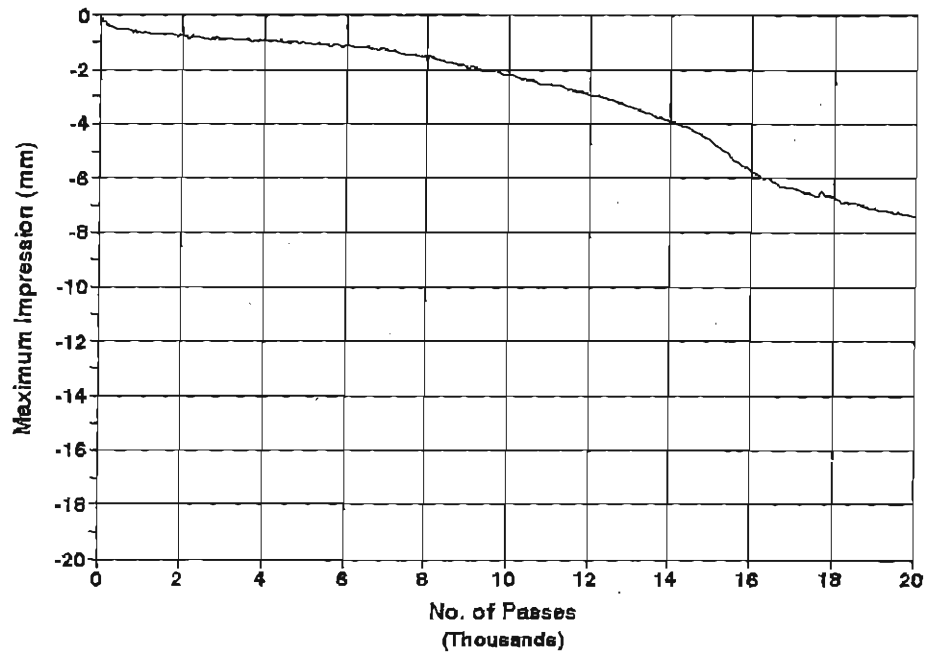

Mix2, Additive B, Type2
Test Temperature = 45 C

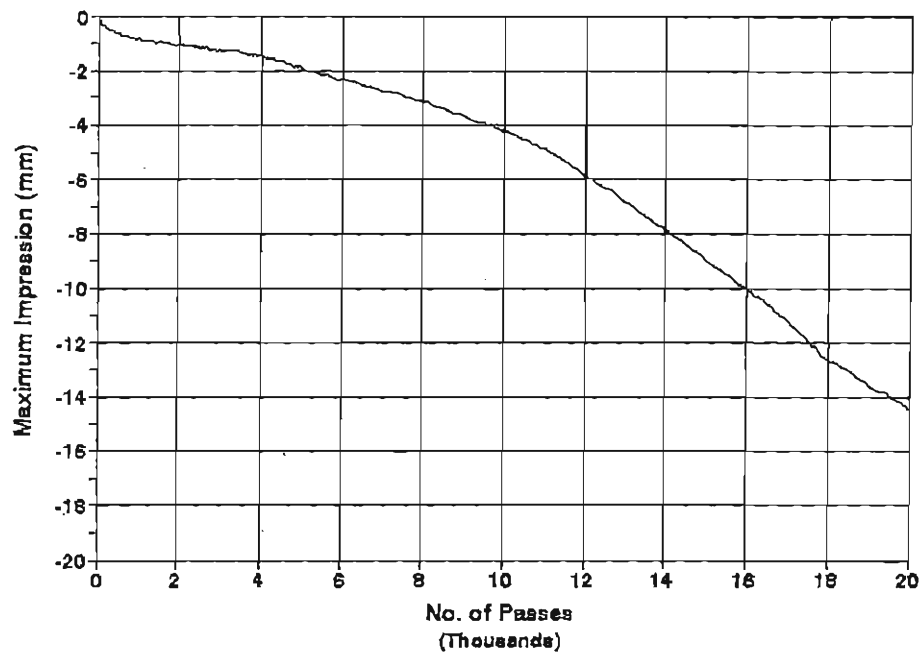

Mix3, Additive B, Type2
Test Temperature = 45 C

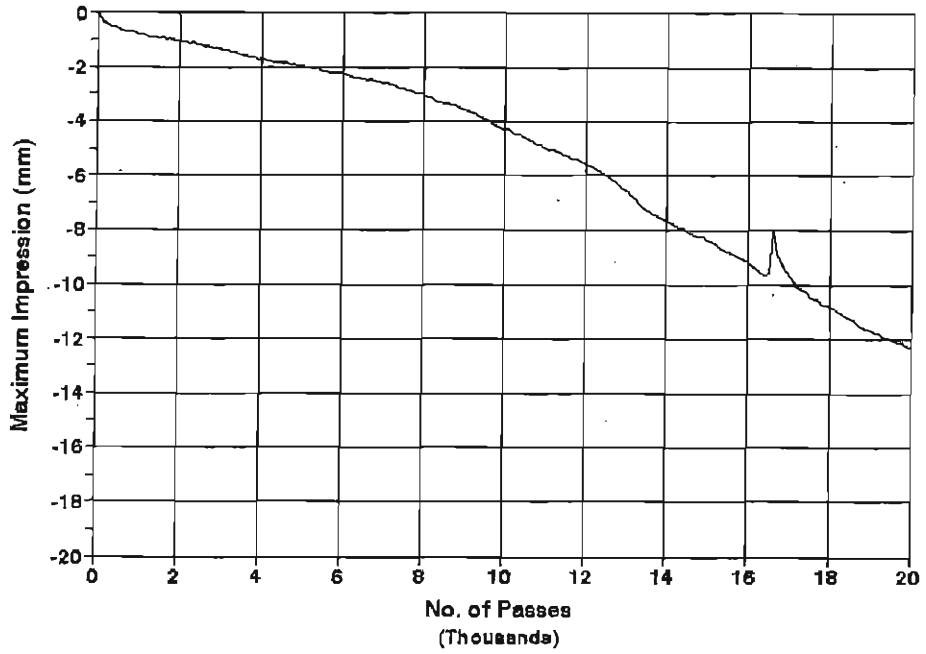

Mix4, Additive B, Type2
Test Temperature = 45 C

