

DESIGNER & DETAILER:
For continuous girders at pier, e.g. steel,
precast panels may continue over pier.
Specify accordingly.
When precast panels are required, add
Pay Item 601-25370 to Summary of
Quantities

NOTES:

- Composite total slab designed for HL-93 Loading.
- All concrete shall be Class PS with release strength $f'ci = 4500$ psi and minimum 28 day strength $f'c = 6000$ psi. Entrained air is not required for precast panel deck form concrete. The strength shall be at least 5000 psi at the time of the deck pour.
- Use $\frac{3}{8}$ " \emptyset low relaxation strands meeting the requirements of ASTM A416 grade 270. Jacking force per strand F_j shall be at least 17.2 Kip. Final force per strand F_f is estimated to be 14.2 Kip.
- Installation of Bar U (#3) is mandatory. Bar U location dimension needs to provide allowance for relocation and design by Fabricator. All panels shall be designed for four-point lifting simultaneously, and balanced lifting loads.
- Care must be taken to ensure proper cleaning of construction debris off the tops of the panels. Water, dirt or other debris on top of the panels will inhibit the bond of the cast-in-place concrete. Panel lengths and width shall be determined by the Contractor and shown on the shop plans.
- The Contractor is responsible for the stability of the panels on the girders. Erected panels shall be uniformly supported along the length of the panel. The Contractor is responsible for meeting the total slab thickness shown on the Superstructure Details.
- All planes of reinforcing steel shown in the superstructure details are required for areas not formed with precast panels.
- Sawing of panels is acceptable in areas where projecting reinforcement is not required. It is desirable to have the prestressing strands project from the panels as long as the projecting strands do not interfere with other bridge components.
- Reinforcing perpendicular to strands may be deformed reinforcing bars, welded wire fabric, or welded deformed bar mats, and shall be placed directly above the strands. Minimum area of reinforcing perpendicular to strands shall be 0.11 Sq In per Ft. Tensioned or untensioned strands may also be used. These individual bars or wires shall be no larger than .375" diameter.
- May be reduced to $\frac{3}{8}$ " \emptyset strands at $9\frac{1}{2}$ " when the panel width is less than 5'-7" and the design span is less than 7'-7".
- The longitudinal reinforcing steel in the cast-in-place portion of the deck may rest directly on the panels as necessary to obtain clearances at the top of deck, unless otherwise noted.
- ⓔ denotes epoxy coated reinforcing.
- The tolerance on strand placement shall not exceed $\pm \frac{1}{4}$ ".
- The tolerance on panel thickness shall not exceed $\pm \frac{1}{4}$ ".
- Concentrated construction loads shall not exceed 500 Lb for 3" panels, 700 Lb for 3.5" panels, nor 1100 Lb for 4" panels unless the load is distributed to less than 117 psf.
- Total loads applied to any panel during construction shall not exceed 117 psf. Bottom flexural cracks, sags greater than $\frac{1}{2}$ ", or cambers greater than $\frac{1}{2}$ " will be considered evidence of mishandling, overloading, or exceeding allowable tolerances, and may be cause for rejecting panels at the Engineer's discretion.

Designer & Detailer: Use the appropriate panel thickness.
3" for panel widths 8'-0" or less and design span of completed slab 10'-0" or less.
3.5" preferred thickness for panel widths 11'-1" or less and design span of completed slab 12'-3" or less.
4" for panel widths 13'-10" or less and design span of completed slab 13'-10" or less.

| |
|----------------|
| Revision Dates |
| 12/20 |
| 3/23 |
| 9/24 |

| | | | | | | |
|------------|--------|------|--------|------|----------|------|
| INITIALS | DESIGN | DATE | DETAIL | DATE | QUANTITY | DATE |
| By | | | | | | |
| Checked By | | | | | | |

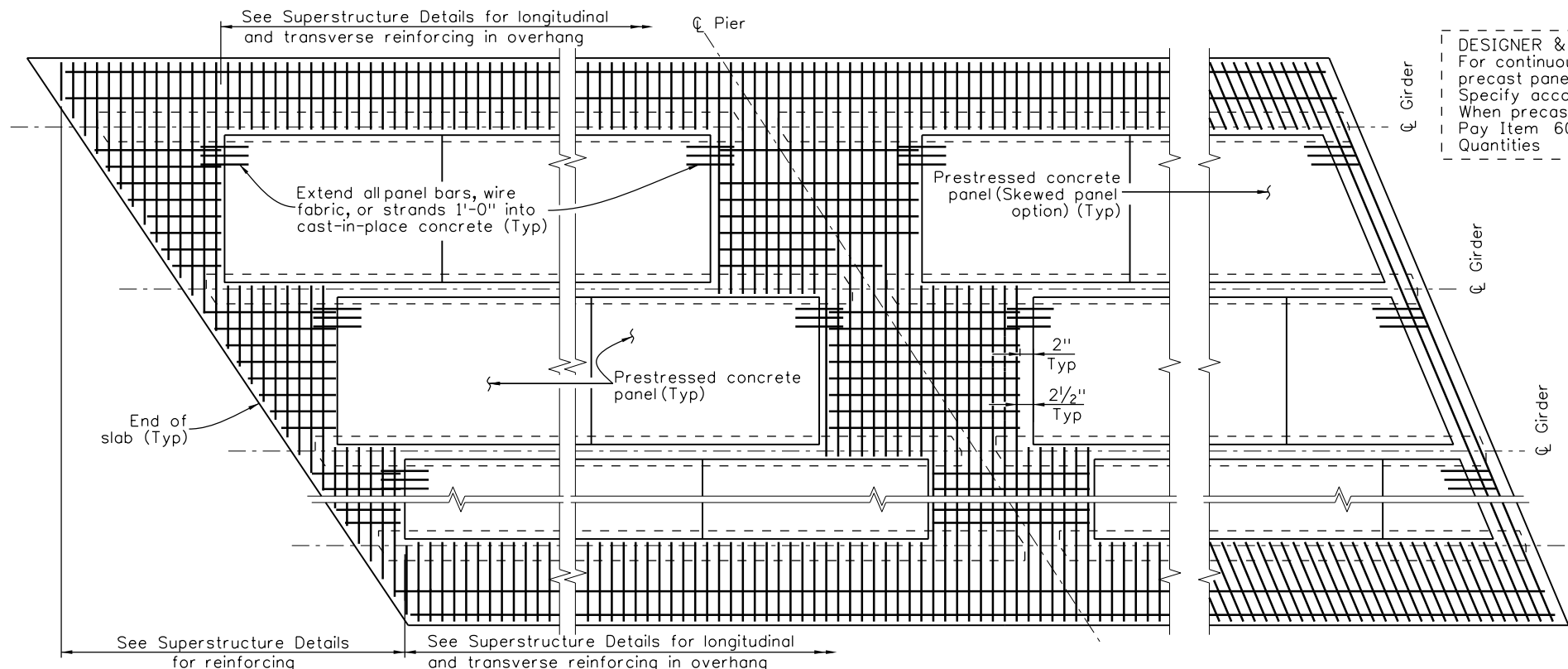

RECTANGULAR PANEL OPTION AND SKEWS GREATER THAN 20°

Rectangular panel option shall be used for skews greater than 20°

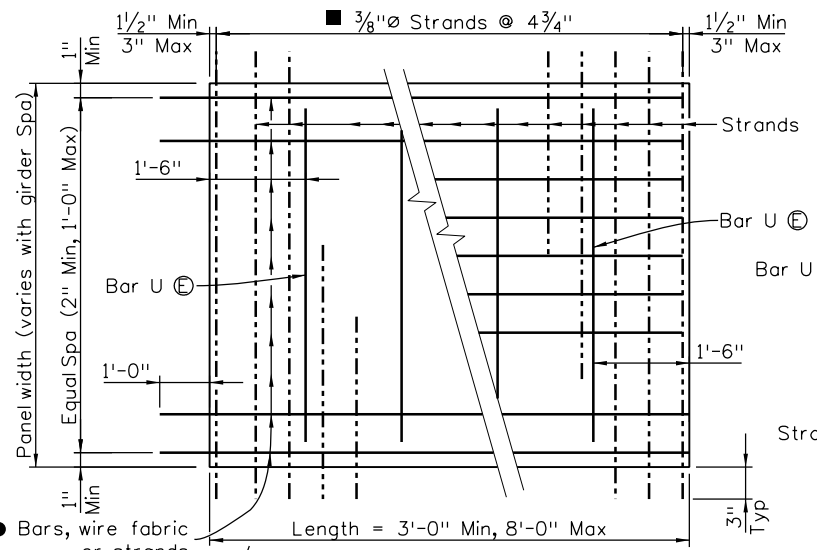

PLAN - NORMAL

Rough finish ($\frac{1}{8}$ " amplitude) top surface. Clean thoroughly by approved methods, free of dirt, loose particles and laitance.

CONTINUOUS SLAB OVER PIER PART PLAN

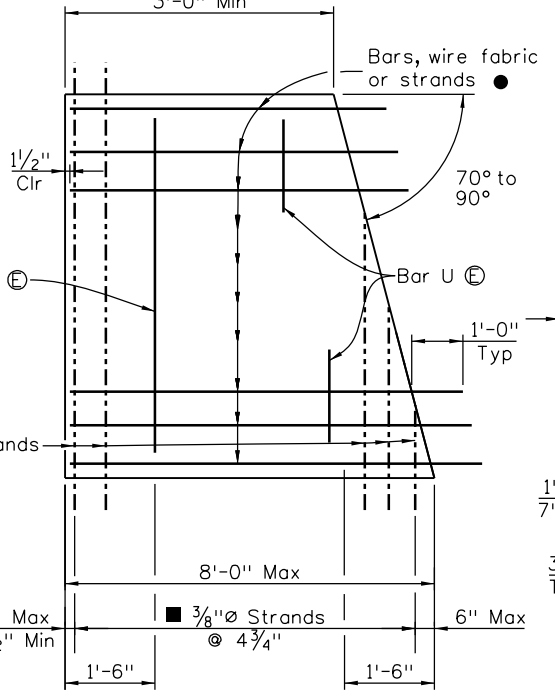

PLAN - SKEWS 70° TO 90° OPTIONAL END PANEL

SKEWED PANEL OPTION FOR SKEWS 0° TO 20°

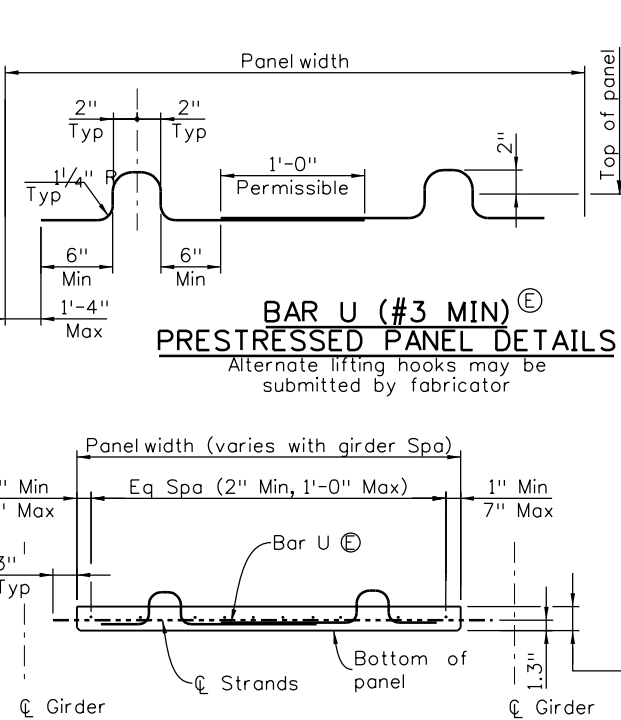

PRESTRESSED PANEL DETAILS

| | | | | | | | | | | | |
|---|--|-----------------|----------|-------|---|--|--|----------------|--|-------------------------|----------------------------|
| All seals for this set of drawings are applied to the cover page(s) | Print Date: \$DATE\$ | Sheet Revisions | | | Colorado Department of Transportation | | | As Constructed | | Project No./Code | |
| | File Name: Sheet_B-601-4.dgn | Date: | Comments | Init. | 2829 West Howard Place, 3rd Floor Denver, CO 80204 Phone: 303-512-4079 FAX: 303-757-9197 | | | No Revisions: | | PRECAST PANEL DECK FORM | |
| | Horiz. Scale: None Vert. Scale: As Noted | | | | | | | Revised: | | Designer: XXXXXXXX | Structure Numbers: X-XX-XX |
| | Unit Information Unit Leader Initials | | | | | | | Void: | | Detailer: XXXXXXXX | X-XX-XX |
| | | | | | Staff Bridge Branch | | | Initials | | Sheet Number | |
| | | | | | | | | Void: | | Sheet Subset: BRIDGE | Subset Sheets: BXX of XXX |