

**GENERAL NOTES**

- AT EACH LOCATION WHERE AN ELECTRIC TRANSMISSION, DISTRIBUTION, OR SECONDARY LINE CROSSES A FENCE, THE CONTRACTOR SHALL FURNISH AND INSTALL A GROUND CONFORMING TO ARTICLE 250 OF THE NATIONAL ELECTRIC CODE. A GROUND SHALL ALSO BE INSTALLED A MAXIMUM OF EVERY 500 FT. ALONG THE FENCE. THE GROUND ROD SHALL BE A MINIMUM DIAMETER OF 1/2 IN. AND 8 FT. IN LENGTH, AND DRIVEN AT LEAST 7 1/2 FT. INTO THE GROUND. THE ROD SHALL BE CONNECTED TO EACH WIRE WITH A MINIMUM AWG NO. 8 STRANDED COPPER WIRE. GROUNDING WILL NOT BE PAID FOR SEPARATELY BUT SHALL BE INCLUDED IN THE COST OF THE FENCE.
- H (HEIGHT OF FABRIC) SHALL BE AS SHOWN ON THE PLANS. FABRIC IS AVAILABLE IN THE FOLLOWING HEIGHTS: 36 IN., 42 IN., 48 IN., 60 IN., 72 IN., 84 IN., 96 IN., 108 IN., 120 IN., AND 144 IN.
- CHAIN LINK FENCE SHALL CONFORM TO AASHTO M 181.
- CHAIN LINK FABRIC SHALL BE 2 IN. MESH NO. 9 GAGE GALVANIZED OR ALUMINUM COATED WIRE SECURELY FASTENED TO TENSION WIRE, LINE POSTS, RAILS, BRACES AND STRETCHER BARS SPACED AS SHOWN HEREON. WIRE FASTENERS AND TIE CLIPS SHALL BE NO. 11 GAGE (W&M) GALVANIZED STEEL WIRE OR NO. 7 GAGE (B&S) ALUMINUM WIRE, AND HOG RINGS SHALL BE NO. 9 GAGE, ALL IN CONFORMANCE WITH ASTM F 626.
- STEEL POSTS, RAILS AND GATE FRAMES SHALL CONFORM TO AASHTO M 181 TYPE 1, GRADE 2.
- AT THE CONTRACTOR'S OPTION, PIPE USED FOR FENCE CONSTRUCTION SHALL CONFORM TO THE DIMENSIONS AND WEIGHTS FOR EITHER "ORDINARY PIPE" OR "ALTERNATIVE PIPE" AS SHOWN ON SHEET 2. "ALTERNATIVE PIPE" SHALL BE HIGH STRENGTH STEEL PIPE CONFORMING TO FEDERAL SPECIFICATION RR-F-191/3C.
- TENSION WIRE SHALL BE CONTINUOUS BETWEEN END OR CORNER POST AND LINE BRACE POST. A TURNBUCKLE OR OTHER APPROVED TIGHTENING DEVICE SHALL BE USED FOR EACH CONTINUOUS SPAN OF TENSION WIRE.
- TENSION WIRE SHALL CONFORM TO AASHTO M 181.
- CONCRETE FOOTINGS SHALL HAVE TOPS CROWNED AT GROUND LEVEL AND SHALL BE CLASS B. CONCRETE WITH LIGHTWEIGHT AGGREGATE CONFORMING TO AASHTO M 195, MAY BE SUBSTITUTED.
- TERMINATION OF FENCE AT BRIDGES OR OTHER STRUCTURES SHALL BE AS SHOWN ON THE PLANS.
- CHAIN LINK FABRIC UP TO 5 FT. HIGH SHALL BE KNUCKLED AT THE TOP AND BOTTOM SELVAGES. FABRIC OVER 5 FT. HIGH SHALL BE TWISTED AND BARBED ON THE TOP SELVAGE AND KNUCKLED ON THE BOTTOM SELVAGE.
- FENCE MAY BE CONSTRUCTED WITH EITHER ROUND PIPE OR ROLL-FORMED STEEL COMPONENTS. THE CONTRACTOR SHALL STATE AT THE PRECONSTRUCTION CONFERENCE, THE TYPE OF CONSTRUCTION AND TYPE OF LINE POST TO BE USED THROUGHOUT THE PROJECT.
- THE CONTRACTOR SHALL BE RESPONSIBLE FOR RE-ESTABLISHING DISTURBED OR DESTROYED SURVEY MONUMENTS TO THE APPROPRIATE ACCURACY IN ACCORDANCE WITH SUBSECTION 625.08 OF THE STANDARD SPECIFICATIONS.

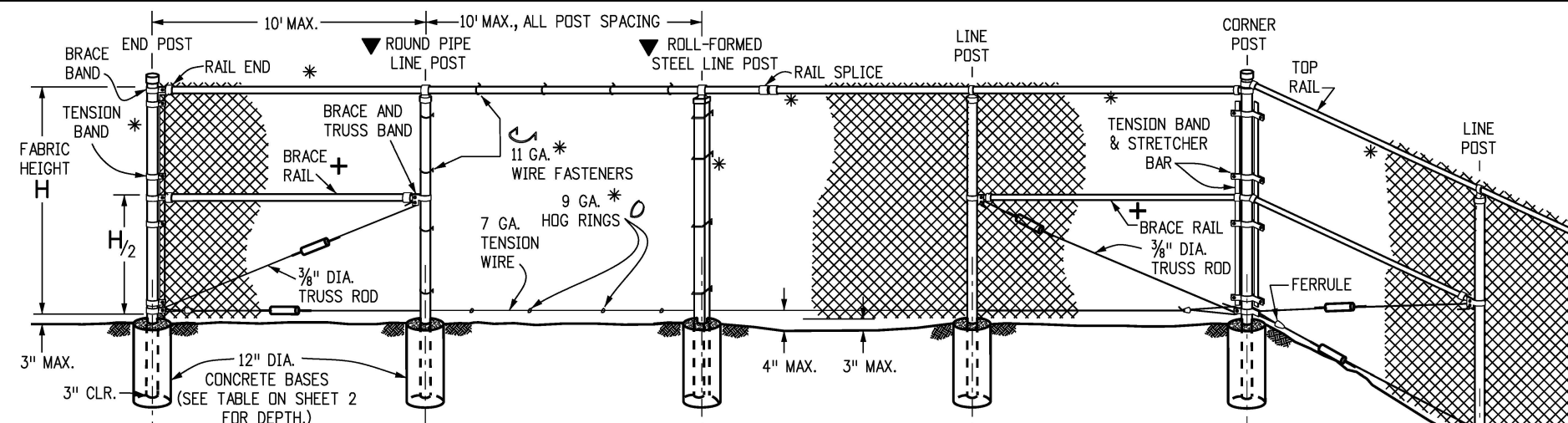

**FENCE WITH TOP RAIL** (USE ONLY AT SPECIAL LOCATIONS BEYOND CLEAR ZONE WHEN THE TOP RAIL IS SPECIFIED ON PLANS)

**LEGEND**

- \* ATTACH FABRIC TO ALL FENCE & GATE STRUCTURES AT 12 IN. INTERVALS VERTICALLY AND AT 20 IN. HORIZONTALLY.
- TIGHTENER OR TURNBUCKLE SYMBOL, (SEE DETAILS ON SHEETS 2 AND 3).
- ▼ TYPE OF LINE POST (ROUND PIPE OR ROLL-FORMED STEEL) SHALL BE AT THE OPTION OF THE CONTRACTOR UNLESS OTHERWISE SHOWN ON THE PLANS.
- + BRACE RAIL IS NOT REQUIRED FOR 36 IN., 42 IN., OR 48 IN. FABRIC HEIGHTS. BRACE RAIL FOR FENCE WITH ROLL-FORMED STEEL ELEMENTS IS 12 IN. BELOW THE TOP RAIL, (SEE SHEET 3).

- \* CASE 1. TO KEEP INSIDERS IN, SLOPE TOP IN 45°
- \* CASE 2. TO KEEP OUTSIDERS OUT, SLOPE TOP OUT 45° BARBED WIRE OVER GATES SHALL NOT BE SLOPED

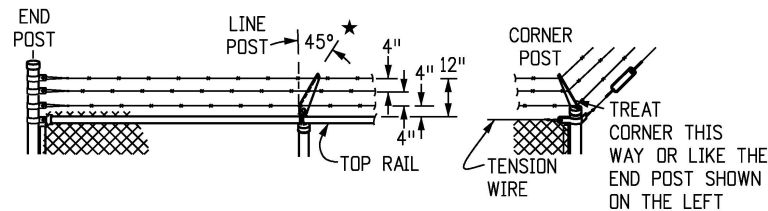

**BARBED WIRE TOP** (USE ONLY WHEN SPECIFIED ON PLANS)

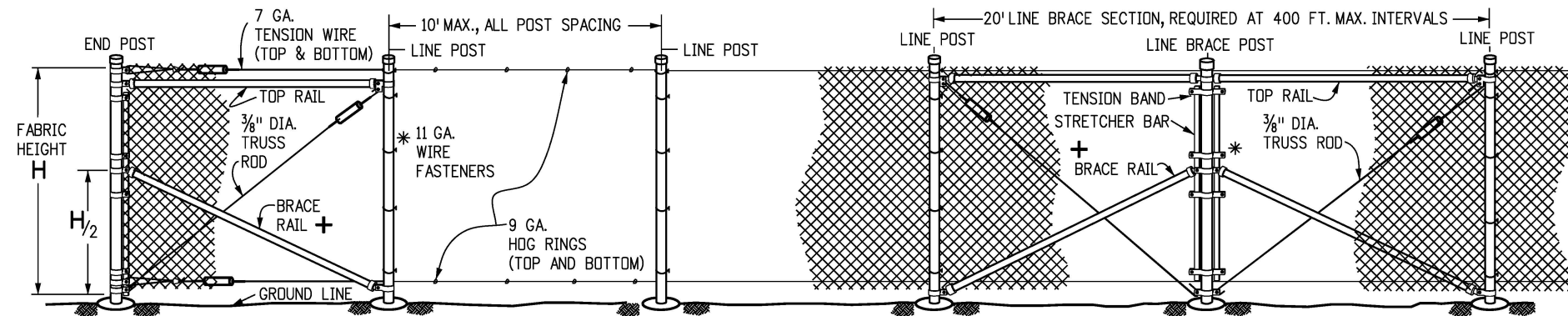

**FENCE WITH TOP TENSION WIRE** (USE FOR STANDARD CHAIN LINK FENCE)

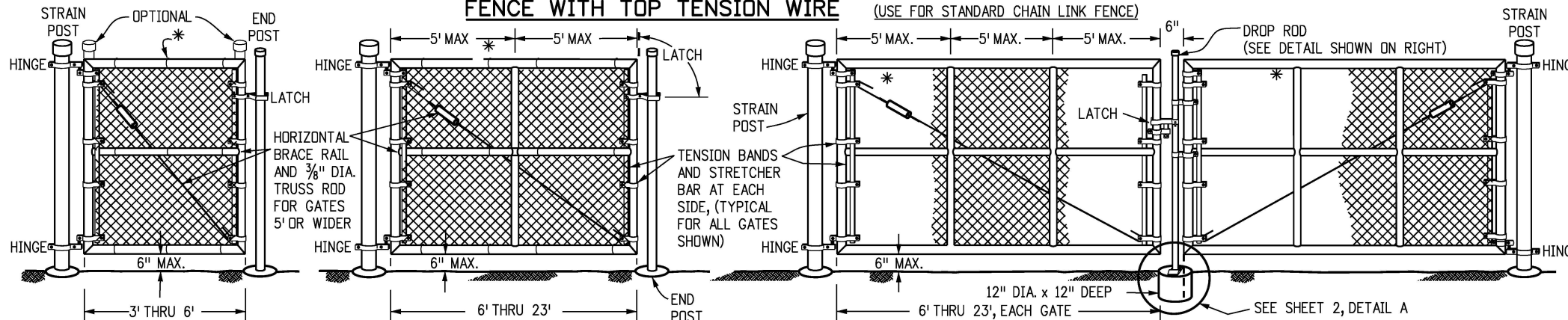

**WALK GATE**

**SINGLE GATE**

**DOUBLE GATE**

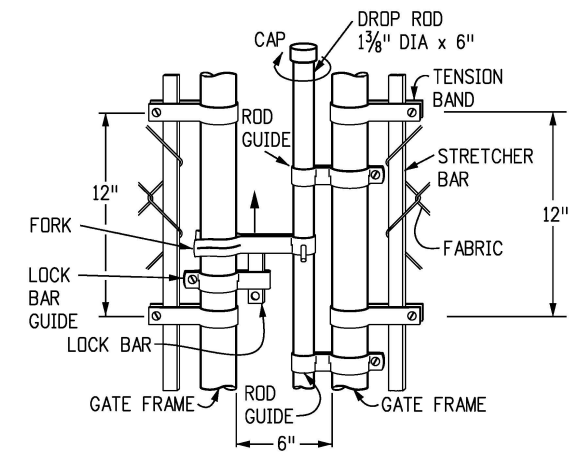

**TYPICAL DROP ROD ASSEMBLY**

**Computer File Information**

Creation Date: 07/31/19  
 Designer Initials: JBK  
 Last Modification Date: 07/31/19  
 Detailer Initials: LTA  
 CAD Ver.: MicroStation V8 Scale: Not to Scale Units: English

**Sheet Revisions**

Date:	Comments
(R-X)	
(R-X)	
(R-X)	
(R-X)	

**Colorado Department of Transportation**

2829 West Howard Place  
 CDDT HQ, 3rd Floor  
 Denver, CO 80204  
 Phone: 303-757-9021 FAX: 303-757-9868

Project Development Branch **JBK**

**CHAIN LINK FENCE**

Issued by the Project Development Branch: July 31, 2019

**STANDARD PLAN NO.**

**M-607-2**

**Standard Sheet No. 1 of 3**

Project Sheet Number:

**FENCE MATERIAL**

FABRIC HEIGHT	END, CORNER AND LINE BRACE POSTS		LINE POSTS		TOP & BRACE RAILS	
	ROUND PIPE I.D.	ROLL-FORMED STEEL	ROUND PIPE I.D.	ROLL-FORMED STEEL	ROUND PIPE I.D.	ROLL-FORMED STEEL
FEET	INCHES		INCHES		INCHES	
3 THRU 6	2.5	3.5 x 3.5	1.5	1.875 x 1.625	1.25	1.25 x 1.625
> 6 THRU 8	2.5	3.5 x 3.5	2.0	1.875 x 1.625	1.25	1.25 x 1.625
> 8 THRU 12	2.5	3.5 x 3.5	2.0	2.250 x 1.625	1.25	1.25 x 1.625

FABRIC HEIGHT	CONCRETE BASE			
	DEPTH		DIA.	
FEET	INCHES		INCHES	
3 THRU 4	34	12	28	12
> 4 THRU 12	40	12	40	12

△ ALL POSTS 3 IN CLEAR FROM BOTTOM OF CONCRETE BASE

**ORDINARY PIPE**

NOMINAL I.D.	O.D.	WALL THICK.	WEIGHT
INCHES			LB/FT
1.25	1.660	0.140	2.27
1.50	1.900	0.145	2.72
2.00	2.375	0.154	3.65
2.50	2.875	0.203	5.79
3.00	3.500	0.216	7.58
3.50	4.000	0.226	9.11
4.00	4.500	0.237	10.79
5.00	5.563	0.258	14.62
6.00	6.625	0.280	18.97
8.00	8.625	0.322	28.55

**ALTERNATIVE PIPE**

NOMINAL I.D.	O.D.	WALL THICK.	WEIGHT
INCHES			LB/FT
1.25	1.660	0.111	1.836
1.50	1.900	0.120	2.281
2.00	2.375	0.130	3.117
2.50	2.875	0.160	4.640

**GATE MATERIAL**

GATE FRAME WIDTH	STRAIN POST		CONCRETE BASE	
	ROUND I.D.	ROLL-FORMED	DEPTH	DIA.
FEET	INCHES		INCHES	
3 THRU 6	2.5	3.5 x 3.5	36	12
> 6 THRU 13	3.5	—	42	12
> 13 THRU 18	6.0	—	48	18
> 18 THRU 23	8.0	—	48	24

GATE FRAME		FRAME PIPE	BRACING PIPE
WIDTH	HEIGHT	I.D.	I.D.
FEET			
INCHES			
3 THRU 8	3 THRU 6	1.25	1.25
> 8 THRU 23	6	1.50	1.25
> 8 THRU 23	> 6 THRU 12	1.50	1.50

**ROLL-FORMED STEEL**

PART	SIZE	THICK.	WEIGHT
	INCHES	GAGE	LB/FT
TOP & BRACE RAILS	1.250 x 1.625	14	2.08
LINE POST (H: 3FT - 6FT)	1.875 x 1.625	12	2.75
LINE POST (H: > 6FT - 8FT)	1.875 x 1.625	11	3.36
LINE POST (H: > 8FT - 12FT)	2.250 x 1.625	11	4.02
END, CORNER & LINE BRACE POSTS	3.50 x 3.50	10	7.59

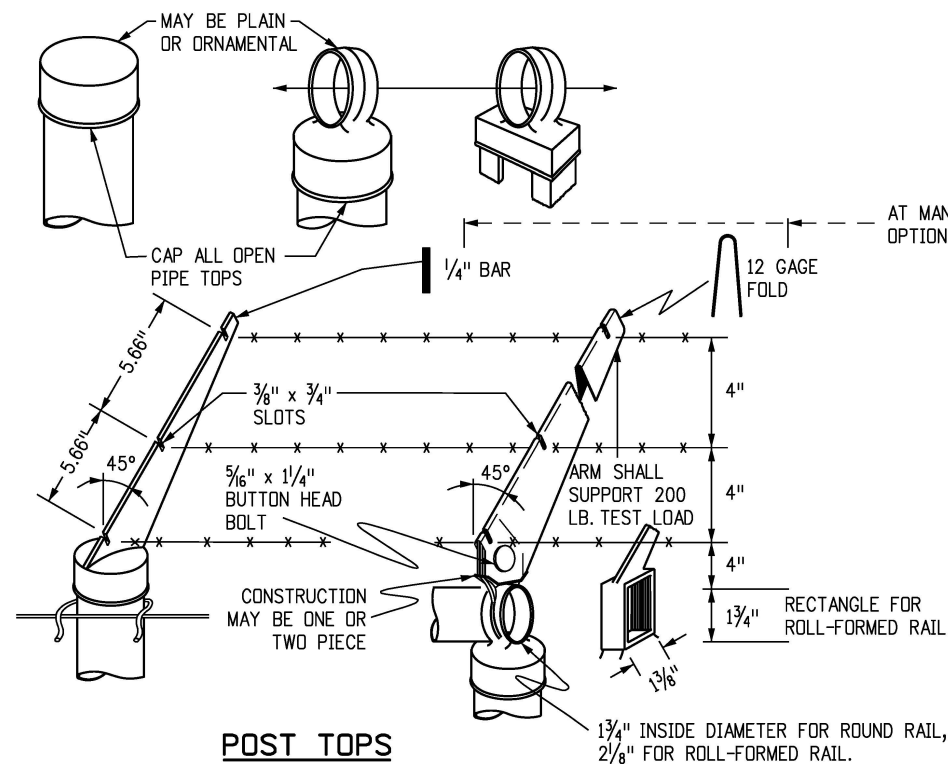

**POST TOPS**

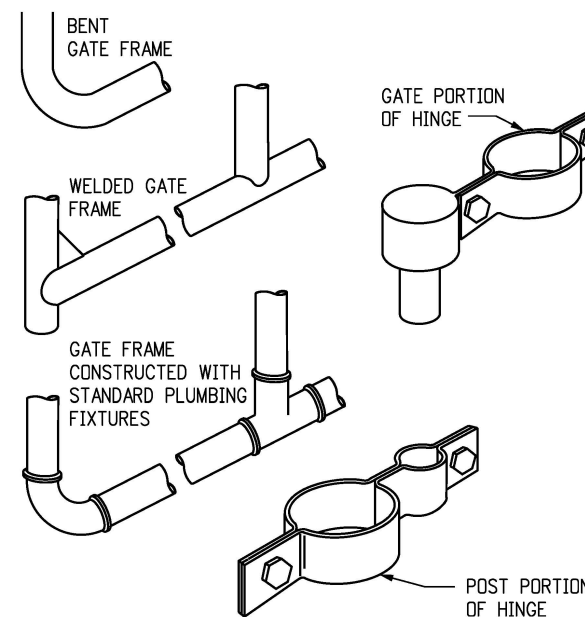

**GATE FRAMES & HINGE**

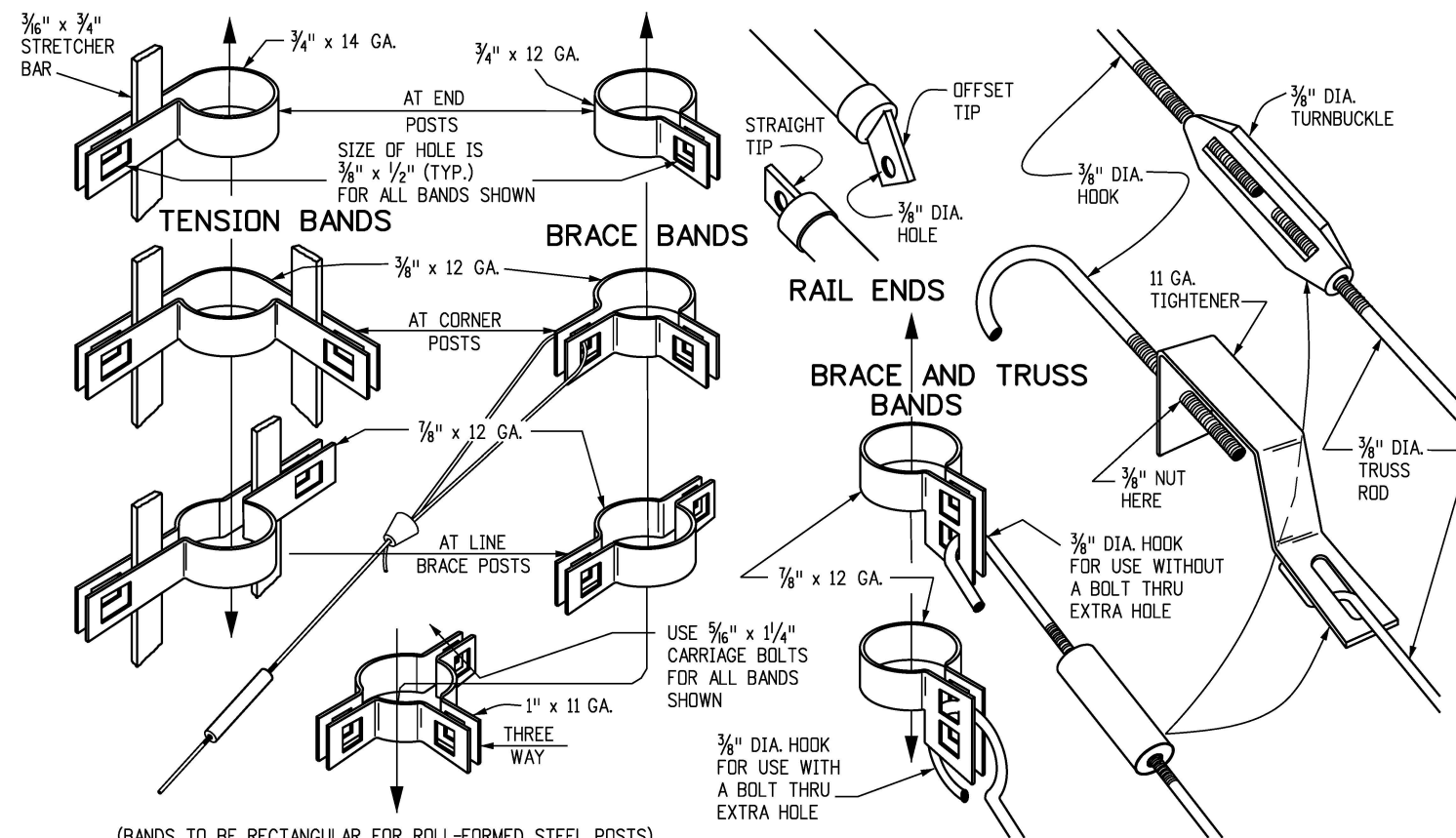

**BANDS, RAIL ENDS & TIGHTENERS** (DIMENSIONS SHOWN ARE MINIMUMS)

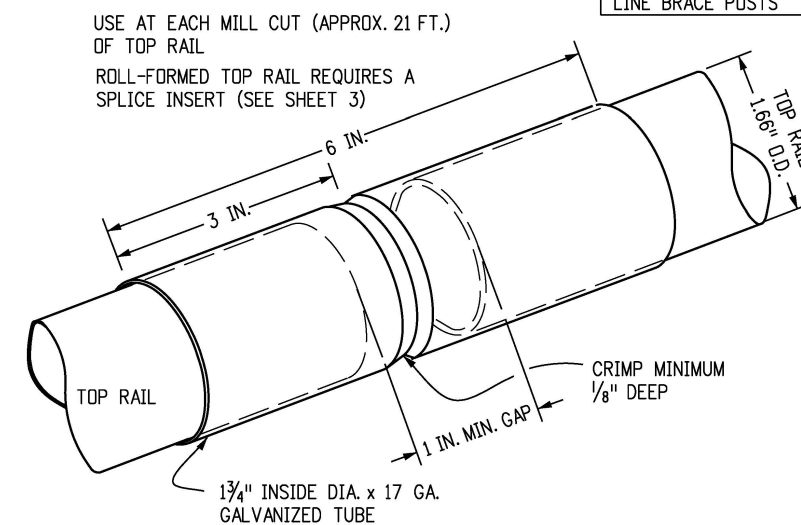

**RAIL SPLICE**

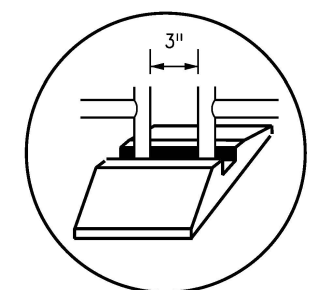

DROP ROD IS OPTIONAL IF GATE FRAMES EXTEND DOWN TO CENTER REST. USE LATCH SHOWN FOR WALK OR SINGLE GATE.

**DETAIL A TYPICAL CENTER REST**

**Computer File Information**

Creation Date: 07/31/19
Designer Initials: JBK
Last Modification Date: 07/31/19
Detailer Initials: LTA
CAD Ver.: MicroStation V8 Scale: Not to Scale Units: English

**Sheet Revisions**

Date:	Comments
(R-X)	
(R-X)	
(R-X)	
(R-X)	

Colorado Department of Transportation

2829 West Howard Place  
CDDT HQ, 3rd Floor  
Denver, CO 80204  
Phone: 303-757-9021 FAX: 303-757-9868

Project Development Branch

JBK

**CHAIN LINK FENCE**

Issued by the Project Development Branch: July 31, 2019

STANDARD PLAN NO.

M-607-2

Standard Sheet No. 2 of 3

Project Sheet Number:

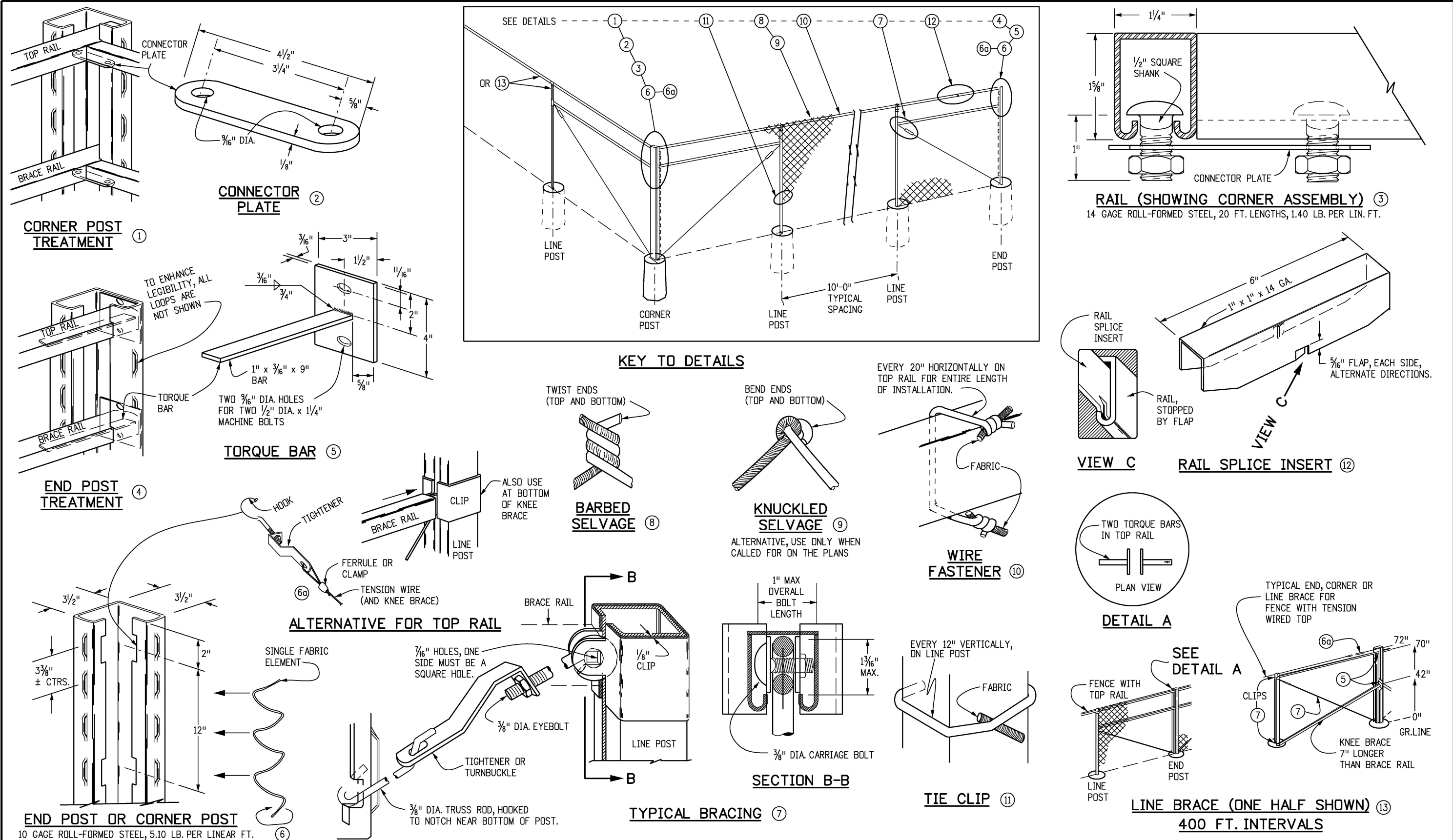

Computer File Information	
Creation Date:	07/31/19
Designer Initials:	JBK
Last Modification Date:	07/31/19
Detailer Initials:	LTA
CAD Ver.:	MicroStation V8
Scale:	Not to Scale
Units:	English

Sheet Revisions	
Date:	Comments
(R-X)	
(R-X)	
(R-X)	
(R-X)	

Colorado Department of Transportation  
 2829 West Howard Place  
 CDDT HQ, 3rd Floor  
 Denver, CO 80204  
 Phone: 303-757-9021 FAX: 303-757-9868  
 Project Development Branch JBK

# CHAIN LINK FENCE

Issued by the Project Development Branch: July 31, 2019

STANDARD PLAN NO. M-607-2
Standard Sheet No. 3 of 3
Project Sheet Number: